

KEEP FOR FUTURE REFERENCE

SERVICE MANUAL



908 W. Main • P.O. Box 368
Laurel, MT USA 59044
800-548-7341 (phone)
406-628-8231 (phone)
406-628-8354 (fax)
www.WPG.com

 **INTENDED FOR USE BY SKILLED
TECHNICAL PROFESSIONALS • READ
AND UNDERSTAND BEFORE SERVICING**



**DC-VOLTAGE
POWER SYSTEM
WITH DUAL VACUUM
SYSTEM AND INTELLI-GRIP®
TECHNOLOGY**

(SOFTWARE VERSION 7.6)

Stock number: 36105



TABLE OF CONTENTS

BEFORE SERVICING LIFTER	2
SERVICE SCHEDULE	2
SERVICE FEATURES	3
TROUBLESHOOTING LIFTER FAULTS	4
TO TROUBLESHOOT USING DIAGNOSTIC CODES	4
TO TROUBLESHOOT USING OTHER ON-SCREEN INFORMATION	4
TO SUBMIT LIFTER DATA TO WPG	5
TO SUBMIT VIDEO TO WPG	5
INTELLI-GRIP[®] DIAGNOSTIC CODES	6
INTELLI-GRIP[®] OPERATOR MENUS	12
TO ACCESS AND NAVIGATE THE OPERATOR MENUS.....	12
TO CHANGE THE SCREEN LANGUAGE	13
TO USE THE LIFTER AT HIGH ELEVATION	13
TO CHANGE THE VACUUM DETECTION THRESHOLD	14
TO CHANGE THE LEAK RATE THRESHOLD	14
TO CHANGE MOBILE APP SETTINGS	15
TO VIEW SYSTEM INFORMATION	16
BATTERY CHARGER TEST	17
SERVICE PROCEDURES	18
AIR FILTER MAINTENANCE – 1 OZ BOWL SIZE	18
Filter Service Procedure.....	18
VACUUM PUMP MAINTENANCE – MODEL 1034204.....	20
Replacing the Diaphragm.....	20
Replacing the Head Assembly.....	20
REPLACEMENT PARTS	21
COPYRIGHT NOTICE	22

BEFORE SERVICING LIFTER



Disconnect battery when necessary to prevent electrical shock or other risks.

Whenever necessary, disconnect the electrical connectors for the battery (figs. 1A-B).

Service personnel must read and understand the lifter's *OPERATING INSTRUCTIONS* – especially the “INSPECTIONS AND TESTS” and “MAINTENANCE” sections – before

servicing the vacuum lifter. Many of the following discussions assume knowledge of the *OPERATING INSTRUCTIONS*.

Note: The final section of the lifter's OPERATING INSTRUCTIONS may contain wiring and/or hose-routing diagrams for reference when servicing or troubleshooting the lifter.

SERVICE SCHEDULE

Service must be performed whenever a deficiency is indicated by routine inspections or tests. Follow the “INSPECTIONS AND TESTS” section of the *OPERATING INSTRUCTIONS*. Any service warranted must be performed before resuming normal operation of the lifter.

1A

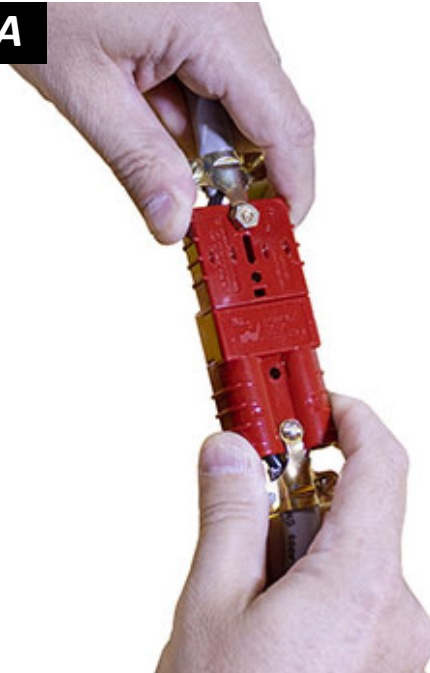

1B

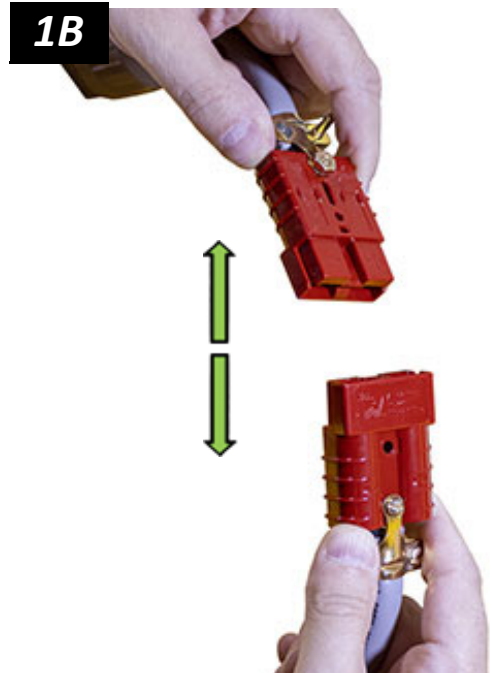

SERVICE FEATURES

Components shown here are underlined> on their first appearance in each section to follow.

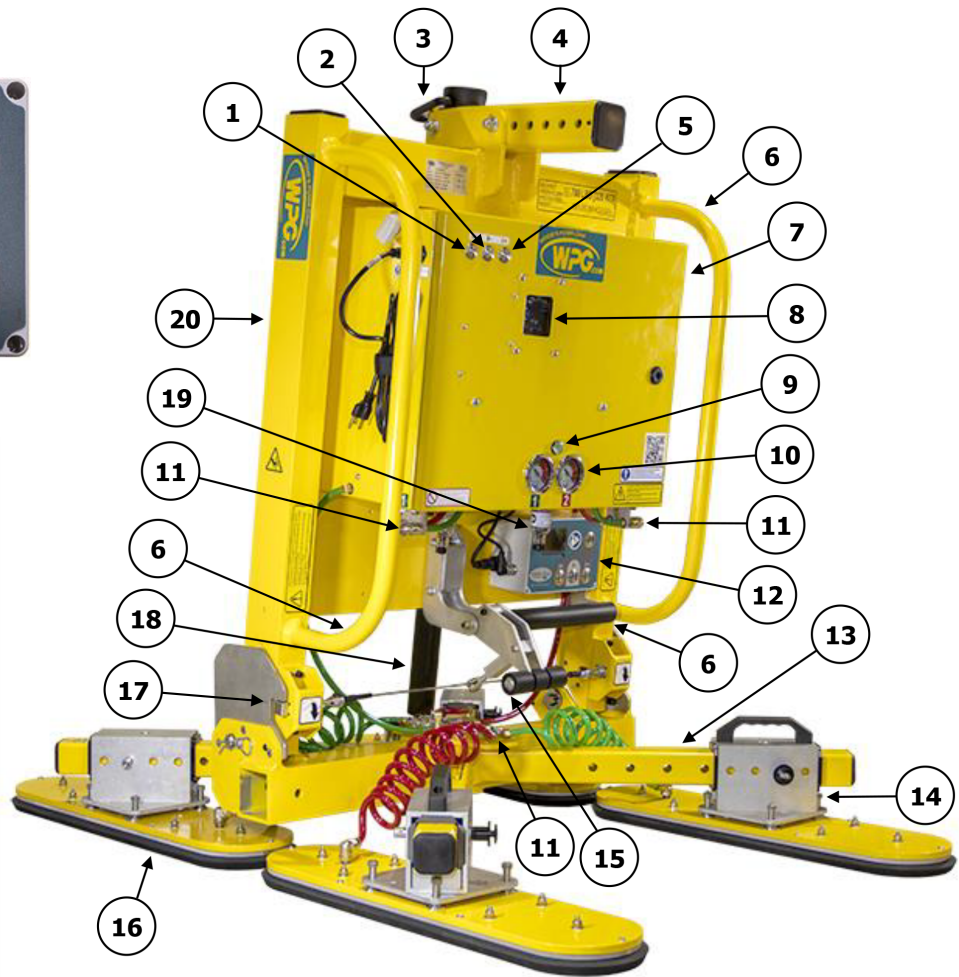
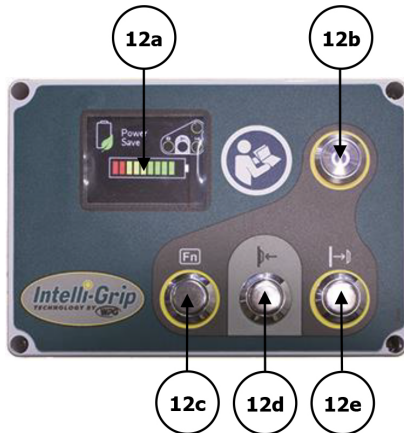

MTCL6625DC3 is shown

- | | | | | | |
|-----|---|-----|------------------------|-----|----------------------------|
| 1 | "FUNCTION" BUTTON | 2 | "ATTACH" BUTTON | 3 | LIFT POINT |
| 4 | ADJUSTABLE LIFT POINT TUBE | 5 | "RELEASE" BUTTON | 6 | CONTROL HANDLE |
| 7 | Enclosure with VACUUM PUMPS, CIRCUIT BOARD AND VACUUM SENSORS | 8 | BATTERY CHARGER WINDOW | 9 | VACUUM LIFT LIGHT |
| 10 | VACUUM GAUGES | 11 | QUICK CONNECTORS | 12 | INTELLI-GRIP® CONTROL UNIT |
| 12a | LCD SCREEN with BATTERY GAUGE | 12b | "POWER" BUTTON | 12c | "FUNCTION" BUTTON |
| 12d | "ATTACH" BUTTON | 12e | "RELEASE" BUTTON | 13 | PAD FRAME |
| 14 | MOVABLE PAD MOUNT | 15 | TILT CONTROL LEVER | 16 | VACUUM PAD |
| 17 | TILT LATCH | 18 | TILT DAMPER | 19 | AIR FILTER |
| 20 | LIFT BAR | | | | |
- Not shown: PAD FRAME EXTENSIONS

← TROUBLESHOOTING LIFTER FAULTS →

Note: When applicable, consult the Troubleshooting Guide [TST-016_GENERIC_LEAK_TEST_rev_2014-086](#).

TO TROUBLESHOOT USING DIAGNOSTIC CODES

Generally, one or more diagnostic codes will show in the bottom-left corner of the lifter's LCD screen, accompanied by a corresponding message below the battery gauge, whenever the lifter has a problem.¹

The example in fig. 1A shows code V012, which indicates vacuum in one of the circuits decreased at faster rate than expected.

Once a code shows, locate the code under “[INTELLI-GRIP® DIAGNOSTIC CODES](#)” and follow directions for the code.

1A

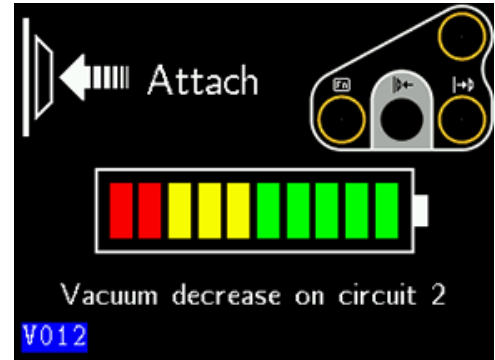

TO TROUBLESHOOT USING OTHER ON-SCREEN INFORMATION

The LCD screen displays other helpful information for troubleshooting (fig. 1B):

- **Button activity (top-right corner).** To test, press each button and make sure its corresponding indicator on the LCD screen lights up (circled).²
- **“Attach”, “Release” or “Power Save” modes (top-left corner).** The mode should reflect the lifter activity prompted by the user. Otherwise, a lifter problem likely exists. For example, the LCD screen should not show “Attach” mode as you attempt to release a load.
- **Battery gauge (center).** This gauge shows the battery's current energy level. For more information, see “[MAINTENANCE: 12-Volt Battery Recharge](#)” and “[OPERATION: BEFORE USING THE LIFTER: Checking the 12-Volt Battery](#)” in the lifter's *OPERATING INSTRUCTIONS*. Additionally, see “[BATTERY CHARGER TEST](#)” in this manual.

1B

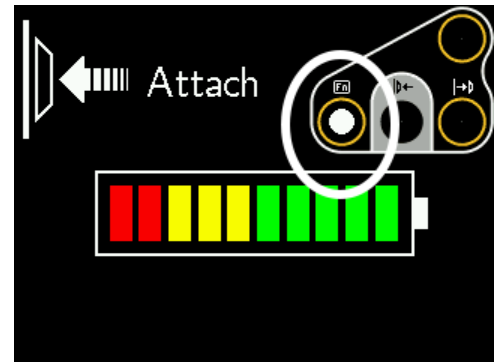

1..... In most cases, a diagnostic code stays on screen only as long as the software detects a problem. Before releasing a load, make sure to record the information showing on the screen.

2..... If the lifter has a Remote Control System, test the radio transmitter's buttons similarly.

TROUBLESHOOTING LIFTER FAULTS

TO SUBMIT LIFTER DATA TO WPG

The WPG Intelli-Grip® App features Live Stream Troubleshooting, which is available for use whenever a lifter problem is not solved using other troubleshooting means. For more information, go to www.wpg.com/app/ and click on the “Live Stream Troubleshooting” link.

An alternative way to send lifter data is to submit digital photo files via email to WPG, including:

- A screenshot of the lifter during startup (fig. 1A).

*Tip: Press **and hold** the “power” button when starting the lifter. This action displays the startup screen as long as needed for you to capture the image.*

Note: If you are not able to access the startup screen, submit a photo file of the serial tag instead.

- Screenshots of “Live Stats” screens (figs. 1B-C). To show these screens, press the power button five times quickly to show the first “Live Stats” screen.¹ After that, each press of the power button will show a different screen until it returns to the normal operation screen.
- Other descriptive photos files, as problems occur.

1A



1B

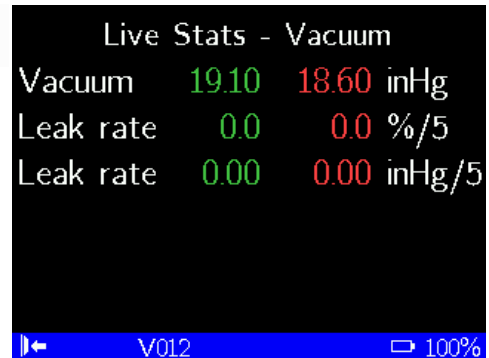

1C

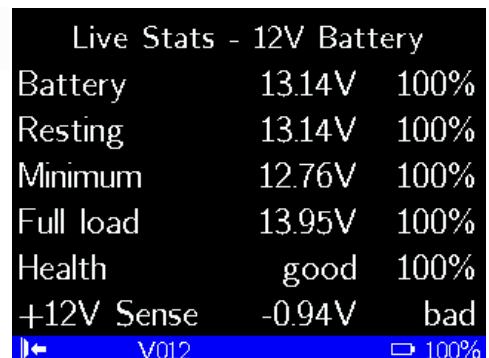

TO SUBMIT VIDEO TO WPG

Whether you use Live Stream Troubleshooting or submit screenshots, you should include video that depicts the lifter problem clearly whenever possible. Describe what the lifter did and what you expected it to do.

Note: Videos may be too large to submit via email. Alternatively, you can upload them to OneDrive, DropBox or a similar file-hosting service and provide a link to WPG.

1..... The lifter must be equipped with software version 5.6 or later to perform this action.

INTELLI-GRIP® DIAGNOSTIC CODES

Refer to the following table whenever a diagnostic code appears on the LCD screen. Codes are listed in alphanumeric order. If the Operator Explanations/Directions do not resolve the issue, follow the Service Personnel Directions. Relevant parts are listed in **“REPLACEMENT PARTS”**.

Code	On-Screen Message	Buzzer Pattern	Strobe Light Activity	Operator Explanations/Directions	Service Personnel Directions
B00	“Low 12V Battery (#)”	1 chirp every 2 seconds	(none)	Charge 12V <u>battery</u> or, if necessary, replace it (see “MAINTENANCE: 12-VOLT BATTERY RECHARGE” in lifter's <i>OPERATING INSTRUCTIONS</i>). Cold battery may need to be warmed and/or charged more often.	Check for faulty 12V <u>battery</u> or malfunctioning charging system. Replace parts as needed.
B01	“Lockout (low 12V battery) (#)”	continuous	(none)	Once “Power Save” mode is activated, “attach” and “release” functions are prevented because 12V <u>battery</u> energy is insufficient. Charge battery before next lift (see “MAINTENANCE: 12-VOLT BATTERY RECHARGE” in lifter's <i>OPERATING INSTRUCTIONS</i>).	Check for faulty 12V <u>battery</u> or malfunctioning charging system. Replace parts as needed.
B02	“Replace 12V battery?”	1 chirp per minute	(none)	Check condition of 12V <u>battery</u> (see “OPERATION: BEFORE USING THE LIFTER: Checking the 12-Volt Battery” and “MAINTENANCE: 12-VOLT BATTERY RECHARGE” in lifter's <i>OPERATING INSTRUCTIONS</i>). Since cold battery may prematurely activate this notification, warm battery and retest when appropriate. Replace battery as needed. Note: This notification can be activated in error if <u>battery charger</u> is plugged into power source while lifter is powered up. If so, power down lifter, disconnect charger from power source, and power up again. If code persists, check battery condition as directed above.	Check for fault(s) with 12V <u>battery</u> or charging system. Replace parts as needed.
B03	“Charge 12V battery soon”	1 chirp per minute	(none)	Charge 12V <u>battery</u> (see “MAINTENANCE: 12-VOLT BATTERY RECHARGE” in lifter's <i>OPERATING INSTRUCTIONS</i>)	N/A
B09	“Replace 9V battery?”	1 chirp per minute	(none)	Replace 9V battery for <u>notification buzzer</u> as needed (see “MAINTENANCE: Notification Buzzer Battery Replacement” in lifter's <i>OPERATING INSTRUCTIONS</i>).	Check 9V battery voltage with multi-meter. If battery is OK, check for bad connection in battery holder or associated wiring.
C00	“Fail-safe on module”	continuous	on	Modular <u>circuit board</u> has activated fail-safe mode, to prevent potential injury. Service is required.	Check for fault(s) in cable connecting to modular <u>circuit board</u> . Disconnect 12V <u>battery</u> and replace cable or circuit board as needed.

INTELLI-GRIP® DIAGNOSTIC CODES

Code	On-Screen Message	Buzzer Pattern	Strobe Light Activity	Operator Explanations/Directions	Service Personnel Directions
C011	"Communication failure, module 1"	fast chirp	(none)	Fault is detected in connection between modular <u>circuit board</u> and <u>control unit</u> . If code does not clear automatically, service is required.	Check for fault(s) in cable connecting to modular <u>circuit board</u> . Disconnect 12V <u>battery</u> and replace cable, circuit board, or <u>control unit</u> as needed.
C021	"Internal error, module 1"	continuous	(none)	Fault is detected in modular <u>circuit board</u> . If code does not clear automatically, service is required.	Disconnect 12V battery and replace modular <u>circuit board</u> .
C03	"Firmware updater detected (#)"	(none)	(none)	Service tool is connected. Remove it before resuming lifter use and contact WPG.	N/A
C04	"Module revision not compatible"	1 chirp every 2 seconds	(none)	Make sure lifter is used within Operating Temperatures (see "SPECIFICATIONS" in lifter's <i>OPERATING INSTRUCTIONS</i>). Then power lifter down and up again. If code persists, the modular <u>circuit board</u> is incompatible or it has failed. Service is required.	Disconnect 12V battery and replace modular <u>circuit board</u> .
C05	"Module revision lockout"	continuous (while button is held)	(none)	Once "Power Save" mode is activated, "attach" and "release" functions are prevented in connection with Code C04. Service is required.	Disconnect 12V battery and replace modular <u>circuit board</u> .
C06	"Control head revision not compatible"	1 chirp every 2 seconds	(none)	Incompatible version of software was installed or <u>control unit</u> has failed. Service is required.	Install current software or disconnect 12V <u>battery</u> and replace <u>control unit</u> , as needed.
C07	"Control head revision lockout"	continuous (while button is held)	(none)	Once "Power Save" mode is activated, "attach" and "release" functions are prevented in connection with Code C06. Service is required.	Install current software or disconnect 12V <u>battery</u> and replace <u>control unit</u> , as needed.
E00 E01 E02 E03 E04	"EEPROM error, cell #"	occasional chirp	(none)	Memory error detected. Service is required.	Impact of memory error can vary. Disconnect 12V <u>battery</u> and replace <u>control unit</u> to resolve.
I000	"I2C error (#)"	single chirp	(none)	Fault(s) detected in cable connecting to modular <u>circuit board</u> . If code does not clear automatically, service is required.	Disconnect 12V <u>battery</u> and replace connecting cable, modular <u>circuit board</u> , or <u>control enclosure</u> as needed.

INTELLI-GRIP® DIAGNOSTIC CODES

Code	On-Screen Message	Buzzer Pattern	Strobe Light Activity	Operator Explanations/Directions	Service Personnel Directions
N00	“Automatic attach”	(none)	(none)	System activated “attach” mode as precaution because significant vacuum was detected, even though no one initiated “attach” function. No corrective action is necessary. However, when appropriate, qualified service personnel can adjust sensitivity to vacuum detection.	Adjust sensitivity of vacuum detection, as appropriate (see “ TO CHANGE THE VACUUM DETECTION THRESHOLD ”).
N01	“Automatic attach”	(none)	(none)	System activated “attach” mode as precaution because load did not release completely. No corrective action is necessary. However, when appropriate, qualified service personnel can adjust sensitivity to vacuum detection.	Adjust sensitivity of vacuum detection, as appropriate (see “ TO CHANGE THE VACUUM DETECTION THRESHOLD ”).
N02	“Automatic attach”	(none)	(none)	System activated “attach” mode as precaution when lifter was powered up, because power was previously lost while load was attached. No corrective action is necessary.	N/A
N03	“Unable to turn module power off”	1 chirp every 2 seconds	(none)	Modular <u>circuit board</u> failed to power down. Remove 9V battery. Disconnect connector between 12V <u>battery</u> and vacuum generating system. Charge battery completely (see “MAINTENANCE: 12-VOLT BATTERY RECHARGE” in lifter’s <i>OPERATING INSTRUCTIONS</i>). Then reconnect battery and try to power down again. If code persists, disconnect connector. Service is required.	Check for fault(s) in cable connecting to modular <u>circuit board</u> . Disconnect 12V <u>battery</u> and replace cable or circuit board as needed.
N04	“Failed to turn controls power off”	1 chirp every 2 seconds	(none)	<u>Control unit</u> failed to power down. Remove 9V battery. Disconnect connector between 12V <u>battery</u> and vacuum generating system. Charge battery completely (see “MAINTENANCE: 12-VOLT BATTERY RECHARGE” in lifter’s <i>OPERATING INSTRUCTIONS</i>). Then reconnect battery and try to power down again. If code persists, disconnect connector. Service is required.	Disconnect 12V <u>battery</u> and replace <u>control unit</u> as needed.
N05	“Unable to turn module power on”	1 chirp every 2 seconds	(none)	Modular <u>circuit board</u> failed to power up. Charge 12V <u>battery</u> (see “MAINTENANCE: 12-VOLT BATTERY RECHARGE” in lifter’s <i>OPERATING INSTRUCTIONS</i>). Then power lifter up again. If code persists, service is required.	Disconnect 12V battery and replace modular <u>circuit board</u> .
N06	“Power-down reminder”	2 chirps	on briefly	Power down to prevent 12V <u>battery</u> discharge when lifter is not in use.	N/A

INTELLI-GRIP® DIAGNOSTIC CODES

Code	On-Screen Message	Buzzer Pattern	Strobe Light Activity	Operator Explanations/Directions	Service Personnel Directions
N07	"Auto power-down disabled"	(none)	(none)	Automatic power-down is prevented. Power down lifter and power up again. If code persists, service is required.	Check for other Diagnostic Codes and perform service as directed.
N08	"Powering down in # seconds"	1 chirp per minute	(none)	Lifter will automatically power down in number of seconds shown. Press any button to cancel action.	N/A
N10	"App-support hardware fault"	(none)	(none)	Fault is detected in hardware that enables communication with mobile app. Power down lifter and power up again. If code persists, service is required.	Disconnect 12V <u>battery</u> and replace <u>control unit</u> to resolve.
U00	"WARNING! Is load attached?"	fast chirp	on	Attempt was made to power down lifter while load was still detected. Lower load onto stable support and release load before powering down lifter.	N/A
U01	"Also hold [Fn] to power down"	(none)	(none)	Hold " <u>function</u> " button and " <u>power</u> " button at same time to power down lifter.	N/A
U02	"Turn off? Let go of buttons"	(none)	(possible)	Use only " <u>function</u> " button and " <u>power</u> " button to power down lifter. Lifter cannot be powered down while any other button is pressed.	N/A
U03	"Timed release: # seconds"	1 chirp per button press	on	Timed release function is activated for number of seconds shown (see "OPERATION: TO RELEASE THE PADS FROM THE LOAD" in lifter's <i>OPERATING INSTRUCTIONS</i>). Press " <u>function</u> " button to cancel action or press " <u>attach</u> " button to override. No corrective action is necessary.	N/A
U04	"Also hold [Fn] to release"	(none)	(none)	Hold " <u>function</u> " button and " <u>release</u> " button at same time to release load.	N/A
U06	"Let go of [Fn] and release"	(none)	on	Use only " <u>attach</u> " button to attach load. While "attach" button is pressed, lifter does not respond to pressing any other button. Release all buttons and press buttons again to activate different function.	N/A
U08	"Menu not available in Attach"	(none)	(none)	Operator menus cannot be accessed while lifter is attached to load.	N/A
U09	"Counterweight not retracted"	continuous	on	"Release" function is prevented because counterweight is not positioned correctly. Reposition counterweight as directed (see Counter-Balancer <i>OPERATING INSTRUCTIONS</i>).	N/A

INTELLI-GRIP® DIAGNOSTIC CODES

Code	On-Screen Message	Buzzer Pattern	Strobe Light Activity	Operator Explanations/Directions	Service Personnel Directions
U10	"Use POWER button for Live Stats"	(none)	(none)	"Power" button (not "function" button) is now used to access Live Stats. No corrective action is necessary.	N/A
U11	"Testing battery - wait to attach"	(none)	(none)	"Attach" function is prevented because <u>battery</u> test is currently in progress. Wait until <u>vacuum pump</u> stops running and try again.	N/A
V000	"INSUFFICIENT VACUUM!"	continuous	on	Immediately lower load onto stable support until adequate vacuum can be obtained. Check load and <u>vacuum pads</u> for damage. Consult relevant topics in "ASSEMBLY", "OPERATION", "INSPECTIONS AND TESTS", and "MAINTENANCE" in lifter's <i>OPERATING INSTRUCTIONS</i> .	Find leak(s) in vacuum system and replace parts as needed.
V001 V002 V003 V004	"INSUFFICIENT VACUUM #!" (# indicates relevant vacuum circuit)	continuous	on	Immediately lower load onto stable support until adequate vacuum can be obtained in vacuum circuit indicated. Check load and <u>vacuum pads</u> for damage. Consult relevant topics in "ASSEMBLY", "OPERATION", "INSPECTIONS AND TESTS", and "MAINTENANCE" in lifter's <i>OPERATING INSTRUCTIONS</i> . This Code can be activated in connection with Code N00.	Find leak(s) in relevant vacuum circuit and replace parts as needed.
V011 V012 V013 V014 V015	"Vacuum decrease on circuit #" (# indicates relevant vacuum circuit)	3 chirps	(none)	Vacuum decreased at a faster rate than expected in circuit(s) indicated. Possible causes include bouncing or landing load, as well as use on rough or porous loads and other sources of vacuum leaks. Consult relevant topics in "ASSEMBLY", "OPERATION", "INSPECTIONS AND TESTS", and "MAINTENANCE" in lifter's <i>OPERATING INSTRUCTIONS</i> to eliminate leaks when possible.	Determine whether reduction in vacuum level is due to leaks or other circumstances. Repair any leak(s) found in relevant vacuum circuit(s). The sensitivity to vacuum level changes can also be adjusted, when appropriate (see "TO CHANGE THE LEAK RATE THRESHOLD").
V020	"Vacuum not increasing normally"	1 chirp every 2 seconds	on	Although lifter began to attach, vacuum level did not increase at normal rate. Make sure all <u>vacuum pads</u> seal securely (see relevant topics in "OPERATION" in lifter's <i>OPERATING INSTRUCTIONS</i>). This Code can be activated by use at high elevation. If so, contact WPG for directions.	Check for fault(s) in vacuum system. Replace parts as needed.

INTELLI-GRIP® DIAGNOSTIC CODES

Code	On-Screen Message	Buzzer Pattern	Strobe Light Activity	Operator Explanations/Directions	Service Personnel Directions
V03A V03B	"Pump running excessively"	1 chirp every 2 seconds	(none)	<u>Vacuum pump</u> is running more often than normal. Likely causes include a significant vacuum leak or difficulty achieving minimum vacuum level due to high elevation. In case of suspected leak, check for fault(s) in vacuum system (see relevant topics in "ASSEMBLY", "OPERATION", "INSPECTIONS AND TESTS", and "MAINTENANCE" in lifter's <i>OPERATING INSTRUCTIONS</i>). In case of high elevation, contact WPG for directions.	Check for fault(s) in relevant <u>vacuum pump</u> (see " VACUUM PUMP MAINTENANCE – MODEL 1034204 ") or in vacuum system. Replace parts as needed.
V040	"Lockout (vacuum sensor error)"	continuous	(none)	Once "Power Save" mode is activated, "attach" and "release" functions are prevented due to a <u>vacuum sensor</u> malfunction. Make sure sensor connectors are correctly plugged into <u>circuit board</u> .	Check wiring and connector for each <u>vacuum sensor</u> . Temporarily switch sensor connectors to determine whether to replace <u>circuit board</u> or manifold assembly (including sensors).
V050	"DANGER! INSUFFICIENT VACUUM!"	continuous	on	Vacuum levels in BOTH circuits are insufficient for lifting. Keep everyone away from suspended load until it can be safely lowered to a stable support. Service is required.	Find leak(s) in both vacuum circuits and replace parts as needed. Do not place lifter back into service until problem is resolved.
V081 V082 V083 V084	"Sensor # error, (low)" (# indicates relevant vacuum circuit)	continuous in "attach" mode; 1 chirp every minute in "Power Save" mode	(none)	<u>Vacuum sensor</u> malfunction in vacuum circuit indicated. Make sure sensor connector is correctly plugged into <u>circuit board</u> .	Check wiring and connector for <u>vacuum sensor</u> . Temporarily switch sensor connectors to determine whether to replace <u>circuit board</u> or manifold assembly (including sensors).
V091 V092 V093 V094	"Sensor # error, (high)" (# indicates relevant vacuum circuit)	continuous in "attach" mode; 1 chirp every minute in "Power Save" mode	(none)	<u>Vacuum sensor</u> malfunction in vacuum circuit indicated. Make sure sensor connector is correctly plugged into <u>circuit board</u> .	Check wiring and connector for <u>vacuum sensor</u> . Temporarily switch sensor connectors to determine whether to replace <u>circuit board</u> or manifold assembly (including sensors).

INTELLI-GRIP® OPERATOR MENUS

The Intelli-Grip® Control Unit features several menus that allow the operator to view more detailed information on the LCD screen and change various settings.

To ACCESS AND NAVIGATE THE OPERATOR MENUS

To access the main Operator Menu, hold the “function” button (Fn) for 5 seconds.

Note: Some operator menus can only be accessed when the lifter is in “Power Save” mode.



To scroll down, press the “release” button (|→|).



To scroll up, press the “attach” button (|←|).



To select an item, press the “function” button (Fn).

When you are finished, scroll to **“Exit Menu”** and press the “function” button (Fn).

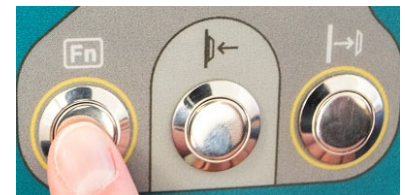

To exit all menus, press the “power” button (⏻).

Note: A similar process is used to navigate all operator menus.



INTELLI-GRIP® OPERATOR MENUS

TO CHANGE THE SCREEN LANGUAGE

- 1) Access the Operator Menu and select “**Language (ABC)**”, as previously directed.
- 2) In the Language (ABC) menu, select your preferred language or “**More options**” to see additional choices.

*Note: If you select “**Graphics only**”, no words of any language are displayed on the LCD screen during typical operation, but English is displayed in the menus.*

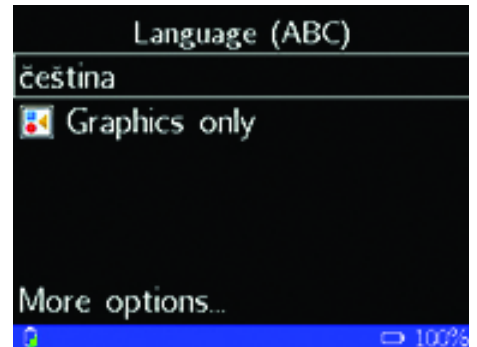
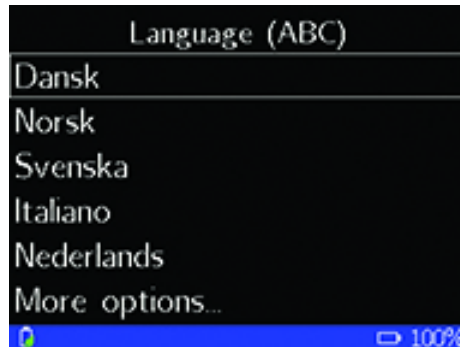

TO USE THE LIFTER AT HIGH ELEVATION

Using the lifter at high elevation may prevent the vacuum generating system from attaining the minimum vacuum level for lifting (see Operating Elevation under “SPECIFICATIONS” in lifter's *OPERATING INSTRUCTIONS*).

- 1) Access the Operator Menu and select “**Lifter Settings**”, as previously directed.
- 2) As indicated in the Lifter Settings menu, you must call Wood’s Powr-Grip to learn more about using the lifter at high elevation.



Note: The phone number is on the cover page of this SERVICE MANUAL.

INTELLI-GRIP® OPERATOR MENUS

TO CHANGE THE VACUUM DETECTION THRESHOLD

As a precaution, the lifter will activate the “attach” mode if vacuum is detected under unusual conditions (see Codes N00, N01 and N02 under “INTELLI-GRIP® DIAGNOSTIC CODES”). If desired, the sensitivity of this feature can be adjusted by following these steps:



- 1) Access the Operator Menu and select “**Lifter Settings**”, as previously directed.
- 2) In the Lifter Settings menu, select “**Vacuum Detection**”.
- 3) In the Vacuum Detection Threshold menu, select the desired sensitivity threshold.

This setting can only be changed using this menu. It will **not** reset automatically when the lifter is powered down.

TO CHANGE THE LEAK RATE THRESHOLD

The lifter will alert the operator if vacuum decreases more quickly than expected (see Codes V011, V012, V013, V014 and V015 under “INTELLI-GRIP® DIAGNOSTIC CODES”). With rough or porous loads, this can result in frequent or constant alarms. To adjust the sensitivity of this feature, follow these steps:



- 1) Access the Operator Menu and select “**Lifter Settings**”, as previously directed.
- 2) In the Lifter Settings menu, select “**Leak Rate Threshold**”.

INTELLI-GRIP® OPERATOR MENUS

- 3) In the Leak Rate Threshold menu, select the desired sensitivity threshold or disable the alarm.

This setting can only be changed using this menu. It will **not** reset automatically when the lifter is powered down.

TO CHANGE MOBILE APP SETTINGS

To make use of WPG's Mobile App, you must enable communication from the lifter to your mobile device, as follows:

- 1) Access the Operator Menu and select **“Lifter Settings”**, as previously directed.
- 2) In the Lifter Settings menu, select **“Mobile App Settings”**.
- 3) In the Mobile App Settings menu, select **“Communication enabled”** to enable communication (**“ON”**).
Select **“Communication enabled”** again to disable communication (**“OFF”**).

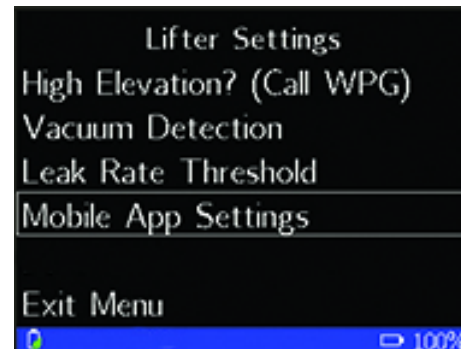

Then press the “power” button (⏻) to complete the change.

Note: If the mobile app notifies you that a firmware update is available, tap the notification and follow the in-app instructions to update the lifter software.

INTELLI-GRIP® OPERATOR MENUS

To View System Information

The lifter keeps a record of the following information:

- Total hours of lifter operation (“Hour Meter”).
- Total number of lifting cycles completed (“Lift Counter”).
- Present voltage of the 12-volt battery (“Battery Voltage”).

To review this information, follow these steps:

- 1) Access the Operator Menu and select **“System Information”**, as previously directed.
- 2) In the System Information menu, find the desired information.



BATTERY CHARGER TEST

The battery charger should function as described in “MAINTENANCE: 12-VOLT BATTERY RECHARGE” in the lifter's *OPERATING INSTRUCTIONS*. If not, the following test allows you to determine whether to replace the charger. Perform this test **only** when the battery is **not** fully charged (see “OPERATION: BEFORE USING THE LIFTER: Checking the 12-Volt Battery” in *OPERATING INSTRUCTIONS*).

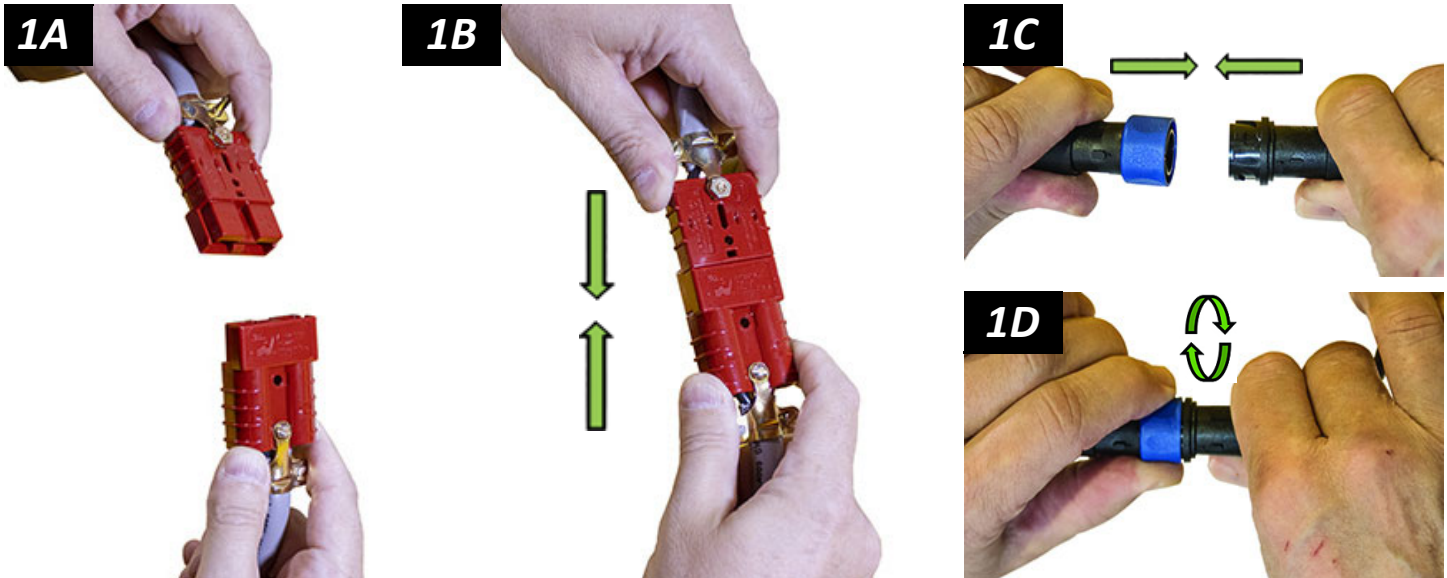

- 1) If electrical connectors for the battery or charger were previously disconnected, reconnect them (figs. 1A-B and figs. 1C-D).
- 2) Make sure the battery charger is **not** plugged into an AC power source. Then access the “Battery Voltage” reading on the LCD screen as previously directed (see “[TO VIEW SYSTEM INFORMATION](#)”).¹

System Information	
Hour Meter	14
Lift Counter	10
Battery Voltage	14.00
Exit Menu	

- 3) Now plug the battery charger into an appropriate AC power source, as directed in the lifter’s *OPERATING INSTRUCTIONS*.

If the charger is functioning correctly, the voltage reading on the LCD screen should begin to increase when the charger is plugged in.

If the charger is **not** functioning correctly, replace it and repeat the test (see “[REPLACEMENT PARTS](#)”).

1..... If the battery is completely discharged, the LCD screen will not display anything. In this case, a voltmeter may be used to determine battery voltage in this test.

SERVICE PROCEDURES

AIR FILTER MAINTENANCE – 1 OZ BOWL SIZE

! *Inspect each air filter regularly, and service when necessary.*

Immediately remove liquid or other contaminants found in the filter bowl (A in fig. 1A), to prevent contact with the filter element (C in fig. 2A).

⊘ *Never use bowl drain (circled in fig. 1A) to remove liquid, because this could cause air leak.*

Replace the filter element whenever:

- It has an overall dirty appearance.
- There is a noticeable increase in the time required to attain full vacuum.

Filter Service Procedure

1) Unscrew the bowl (item A in fig. 1A) from the body (item B in fig. 1A) of the air filter.

Note: To protect air-line fittings from damage, hold the body while turning the bowl.

2) Determine whether the filter element (item C in fig. 2A) needs to be replaced (see above).

- *If so, proceed to step 3.*
- *If not, remove any liquid or contaminants from the bowl; clean the old bowl seal (see step 4 on next page) with mild soap and water; and skip to step 6.*

3) Carefully unscrew the element holder (item D in fig. 3A) and remove all internal parts (fig. 3B).

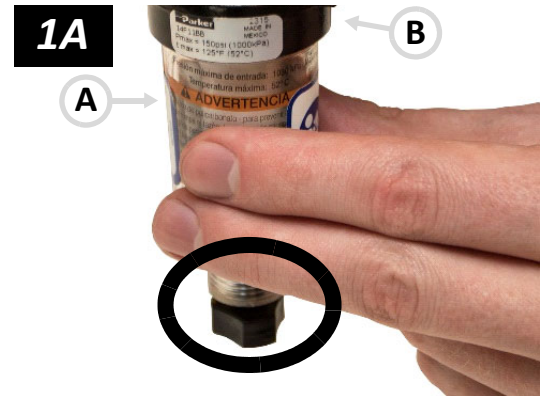
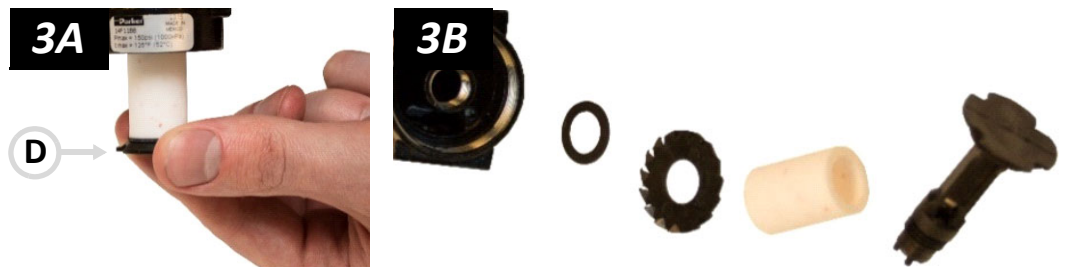

SERVICE PROCEDURES

- 4) Identify the parts in the Filter Element Kit (#16134), including the element (item A in fig. 4A), element holder (B), lubricant (C), deflector (D), element gaskets (E), bowl seal (F). Then dispose of the corresponding old parts.



- 5) Place the new element gaskets, element and deflector on the element holder as shown in fig. 5A. Then screw the assembly back into the filter body.



Note: Tighten gently – finger-tight.

- 6) Clean the bowl, using mild soap and water only.

Caution: Do not use any other cleaning agents.

- 7) Lubricate the new or cleaned bowl seal using a mineral-based oil or grease, such as that provided in the filter element kit.

Caution: Do not use synthetic oils, such as esters, and do not use silicones.

Then place the bowl seal around the rim of the bowl.

- 8) Screw the bowl back into the body. Hand-tighten only.

Caution: Do not contaminate the filter element with lubricant from the bowl seal.

- 9) Perform the “Vacuum Test” to be certain the air filter does not leak (see “INSPECTIONS AND TESTS: TESTING” in the lifter's OPERATING INSTRUCTIONS).

Note: Repeat this procedure for any other filter of the same type.

SERVICE PROCEDURES

VACUUM PUMP MAINTENANCE – MODEL 1034204



Disconnect power source before proceeding.



If the vacuum pump takes too long to attain full vacuum, replace the diaphragm or the head assemblies as necessary to obtain acceptable pump performance (fig. 1A). Perform the following maintenance on both heads of the pump. Then perform the “Vacuum Test” (see “INSPECTIONS AND TESTS: Testing” in the lifter’s *OPERATING INSTRUCTIONS*).

Caution: Do not overtighten head screws, because this may damage the threads in the pump body.

Replacing the Diaphragm

- 1) Remove the four head screws (item 1 in fig. 1A) and lock washers (item 2), and remove the head assembly (item 3).
- 2) Remove the diaphragm retaining screw (item 4), diaphragm (item 5), rubber O-ring (item 6) and flat washer (item 7). Be sure to note the diaphragm orientation for reassembly.
- 3) Replace the flat washer, rubber O-ring, diaphragm and diaphragm retaining screw.
- 4) Reverse the steps above to reassemble.

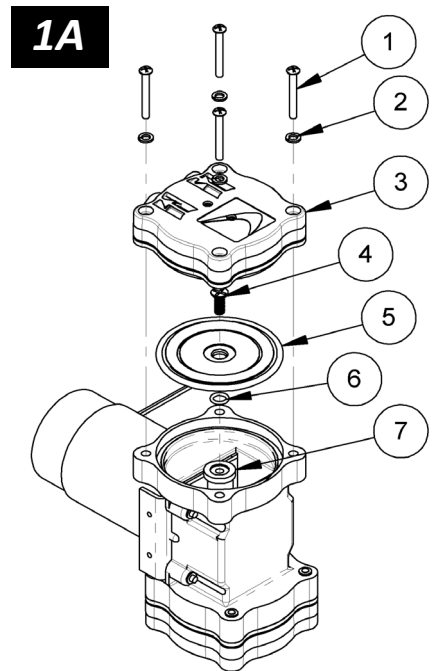

- 1 HEAD SCREW
- 2 LOCK WASHER
- 3 HEAD ASSEMBLY (#66197AA)
- 4 DIAPHRAGM RETAINING SCREW
- 5 DIAPHRAGM (#66197AM)
- 6 RUBBER O-RING
- 7 FLAT WASHER

Replacing the Head Assembly¹

- 1) Remove the hose fittings from the head assembly, and carefully clean the threads. Be sure to note the fitting locations for reassembly.
- 2) Remove the four head screws (item 1 in fig. 1A), lock washers (item 2) and head assembly (item 3).
- 3) Replace the head assembly (reverse *step 2*).
- 4) Reinstall the hose fittings, using an appropriate thread sealant.

1..... **Caution:** Depending on the product, the head assembly (item 3 in fig. 1A) may be rotated to an orientation different from the one shown. When removing the head assembly, always take note of its orientation and install it the same way during reassembly.

REPLACEMENT PARTS

Stock No.	Description	Qty.
66197AM	Pump Diaphragm Kit	4
66197AA	Pump Dual-Head Assembly	4
65211	Check Valve – 1/8 NPT	2
64752A	Audio Alarm – 5-15 V DC – Panel Mount	1
64713AU	Battery Charger – 7 Amp – 220 / 240 V AC – Australian Type	1
64712US	Battery Charger – 7 Amp – 100 / 115 V AC	1
64711EU	Battery Charger – 7 Amp – 220 / 240 V AC	1
64670	Battery – 12 V DC – 35 Amp-Hours	1
64460	Circuit Breaker – 15 A	1
64457B1	Module Circuit Board – Populated	1
59906	Remote Control System Retrofit Kit	1
59901VM	Solenoid Valve – 12 V DC – 4 W – Latching	2
59901BM	Intelli-Grip® Control Unit	1
59900VM	Solenoid Valve – 12 V DC – 4 W	2
59900PM	Vacuum Pump– Diaphragm Type – 2.5 SCFM – 12 V DC	2
59900LA	Strobe Light – 12 V DC – Amber	1
59900GM	LED Indicator – 12 V DC – Green (aka, vacuum lift light)	1
59900BA	Battery Holder – 9 V DC (for notification buzzer)	1
59086NC	Battery Connector – Twin Lead	1
16134	Element Kit for Air Filter – 1 oz Bowl Size	2
15920	Vacuum Gauge – 1/8 NPT – CBM Type – w/Panel Mount Bracket – 16" Hg [-54 kPa]	2

*See lifter's **OPERATING INSTRUCTIONS** for additional parts.*

**SERVICE ONLY WITH IDENTICAL REPLACEMENT PARTS,
AVAILABLE AT WPG.COM OR THROUGH AN AUTHORIZED WPG DEALER**

COPYRIGHT NOTICE

Portions of the source code for this product require reproduction of a copyright notice or a permission notice in the distribution. These notices are included below:

Software Name: Tiva Peripheral Driver Library

License Type: BSD-3-Clause

Copyright © 1998 Todd C. Miller <Todd.Miller@courtesan.com>

All rights reserved.

Redistribution and use in source and binary forms, with or without modification, are permitted provided that the following conditions are met:

- 1) Redistributions of source code must retain the above copyright notice, this list of conditions and the following disclaimer.
- 2) Redistributions in binary form must reproduce the above copyright notice, this list of conditions and the following disclaimer in the documentation and/or other materials provided with the distribution.
- 3) The name of the author may not be used to endorse or promote products derived from this software without specific prior written permission.

THIS SOFTWARE IS PROVIDED "AS IS" AND ANY EXPRESS OR IMPLIED WARRANTIES, INCLUDING, BUT NOT LIMITED TO, THE IMPLIED WARRANTIES OF MERCHANTABILITY AND FITNESS FOR A PARTICULAR PURPOSE ARE DISCLAIMED. IN NO EVENT SHALL THE AUTHOR BE LIABLE FOR ANY DIRECT, INDIRECT, INCIDENTAL, SPECIAL, EXEMPLARY, OR CONSEQUENTIAL DAMAGES (INCLUDING, BUT NOT LIMITED TO, PROCUREMENT OF SUBSTITUTE GOODS OR SERVICES; LOSS OF USE, DATA, OR PROFITS; OR BUSINESS INTERRUPTION) HOWEVER CAUSED AND ON ANY THEORY OF LIABILITY, WHETHER IN CONTRACT, STRICT LIABILITY, OR TORT (INCLUDING NEGLIGENCE OR OTHERWISE) ARISING IN ANY WAY OUT OF THE USE OF THIS SOFTWARE, EVEN IF ADVISED OF THE POSSIBILITY OF SUCH DAMAGE.