

KEEP FOR FUTURE REFERENCE



**P.O. Box 368 – 908 West Main
Laurel, MT USA 59044
phone 800-548-7341
phone 406-628-8231
fax 406-628-8354**

INSTRUCTIONS

International Version

MODEL NUMBER: MR1611LDC

SERIAL NUMBER: _____
(please see serial label and record number here)

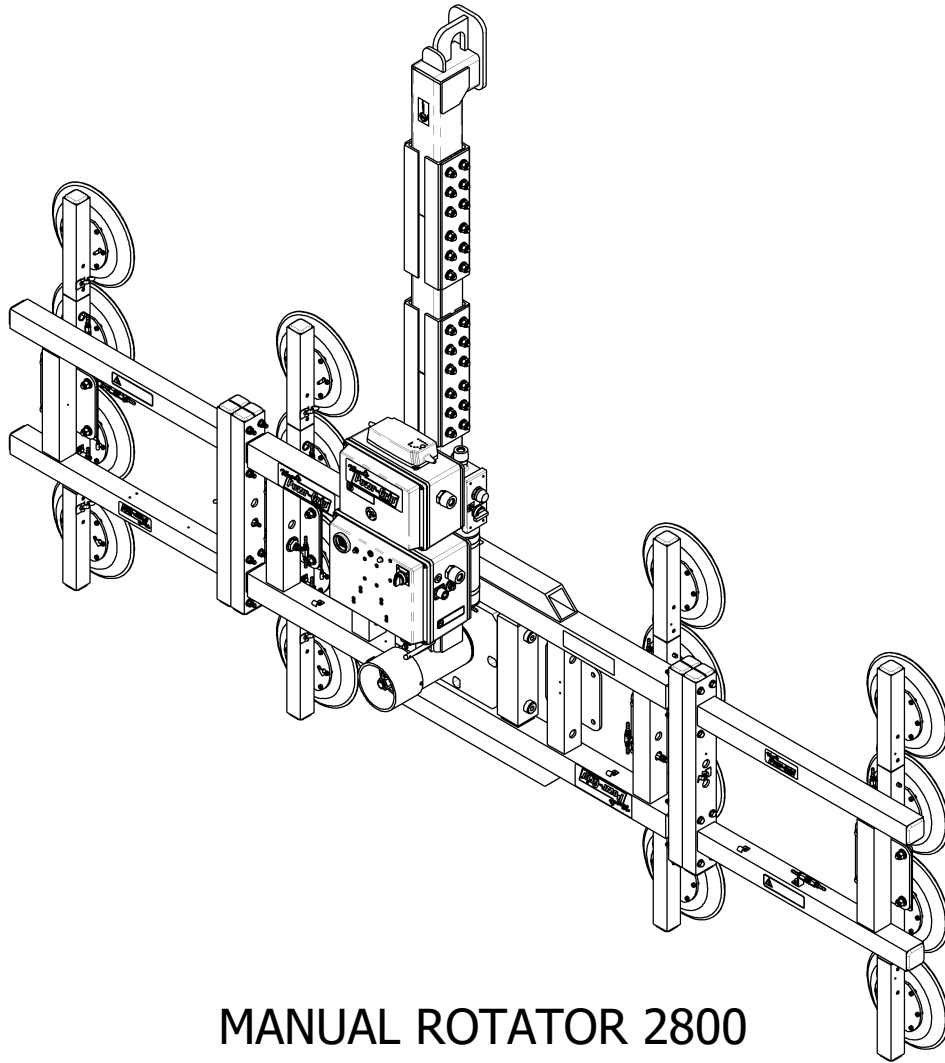

**MANUAL ROTATOR 2800
DC-VOLTAGE**



***READ ALL INSTRUCTIONS AND WARNINGS
BEFORE OPERATING THIS LIFTER***



DESIGNED FOR THE MATERIALS HANDLING PROFESSIONAL

TABLE OF CONTENTS

SPECIFICATIONS	3
WARNINGS	4
OPERATING FEATURES	5
ASSEMBLY	6
To SET UP THE LIFTER	6
To CHANGE THE PAD FRAME CONFIGURATION	7
To Install (and Remove) the Lift Bar Extension	8
To Install (and Remove) the Optional Short Lift Bar	8
To Install (and Remove) the Removable Sections of the Pad Frame	8
To Install (and Remove) Removable Pad Arms	9
To Rotate Rotating Pad Arms	9
INTENDED USE	10
LOAD CHARACTERISTICS	10
OPERATING ENVIRONMENT	11
DISPOSAL OF THE LIFTER	11
OPERATION	12
BEFORE USING THE LIFTER	12
Taking Safety Precautions	12
Performing Inspections and Tests	12
Confirming the Pad Frame Configuration	13
Preparing to Use the Optional Remote Control System	13
To ATTACH THE PADS TO A LOAD	14
Powering up the Lifter	14
Positioning the Lifter on the Load	14
Sealing the Pads against the Load	15
Reading the Vacuum Gauge	16
Vacuum Level on Optimal Surfaces	16
Vacuum Level on Other Surfaces	16
To LIFT AND MOVE THE LOAD	17
Load Capacity and the Lift Light	17
Monitoring Vacuum Indicators	17
Monitoring the Low Vacuum Warning Buzzer (if applicable)	18
Controlling the Lifter and Load	18
In Case of Power Failure	18
To ROTATE THE LOAD	19
To RELEASE THE PADS FROM THE LOAD	20
AFTER USING THE LIFTER	21
Storing the Lifter	21

MAINTENANCE	22
INSPECTION SCHEDULE.....	22
Every-Lift Inspection	22
Frequent Inspection	22
Periodic Inspection.....	22
Infrequent Use.....	23
TESTING SCHEDULE.....	23
Operational Tests.....	23
Load Test	23
MAINTENANCE SCHEDULE.....	24
BATTERY TEST	24
BATTERY RECHARGE	25
VACUUM PAD MAINTENANCE.....	26
Friction Coefficient	26
Inspection	26
Cleaning	26
VACUUM TEST	27
REMOTE CONTROL SYSTEM TEST	28
AIR FILTER MAINTENANCE – LARGE	29
Filter Function and Conditions Requiring Service	29
Filter Service Procedures	29
VACUUM PUMP MAINTENANCE – THOMAS 2907CDC22/12	30
Replacing a Diaphragm (1)	30
Replacing an Intake Valve Flapper (6)	30
Replacing a Set of Exhaust Valve Flappers (9 & 10) and a Head Gasket (12)	30
VACUUM PUMP MAINTENANCE – DYNAFLO DV1032102	31
Replacing the Diaphragm	31
Replacing the Head Assembly	31
VACUUM SWITCH ADJUSTMENT	32
Vacuum Switch Function	32
Conditions Requiring Readjustment.....	32
Adjustment Procedure.....	33
REPLACEMENT PARTS LIST	34
LIMITED WARRANTY.....	35

SPECIFICATIONS

Model Number:	MR1611LDC
Description:	Designed for use with a crane or other hoisting equipment, the MR1611LDC lifter employs vacuum to hold a load for lifting, and it provides manual 360° rotation movements for load manipulation.
Power Source:	12 volts DC, 26 amps
Battery Capacity:	26 amp-hours
Vacuum Pads:	Sixteen 11" [28 cm] nominal diameter, lipped (Model G3370), standard rubber, spring-mounted (¼" [7 mm] travel), with #60 filter screen
Pad Spread: ¹ (to outer edges)	Minimum Maximum
Length:	40¾" [103 cm] 169" [430 cm]
Width:	12" [30 cm] 49" [125 cm]
Load Capacity: ¹	(rated at 16" Hg [-54 kPa] on clean, smooth, nonporous flat surfaces ²)
Per-Pad:	175 lbs [79.5 kg]
Maximum (w/4 pads):	700 lbs [320 kg]
Maximum (w/16 pads):	2,800 lbs [1,270 kg]
Lifter Weight:	685 lbs [311 kg]
Rotation Capability:	Manual, 360°, with automatic locking at each ¼ revolution (when desired)
Vacuum Pumps:	2 diaphragm type, 1 SCFM [28 liters/minute] nominal airflow <i>or</i> 1 diaphragm type, 3 SCFM [85 liters/minute] nominal airflow
Vacuum Reserve Tank:	Vacuum reservoir helps prevent immediate vacuum loss in case of power failure and extends battery life by reducing pump cycles required to maintain vacuum.
Vacuum Gauge:	Dial gauge indicates current vacuum level in positive inches of Hg and negative kPa.
Vacuum Lift Light:	Green light is energized whenever vacuum level is sufficient for lifting maximum load weight (higher than 16" Hg [-54 kPa]).
Low Vacuum Warning Buzzer: (if applicable)	Max Alarm Volume = 103 dBA at 2 ft [60 cm]. While the lifter is powered up, an audible alarm warns the operator whenever vacuum is not sufficient for lifting the maximum load weight.
Options:	<i>Available</i> with Remote Control System. The system uses a 310-320 MHz signal. <i>Available</i> with Short Lift Bar. This option is designed for applications involving minimal clearance between the lifter and the hoisting equipment, such as installations under eaves or similar low-clearance situations. Maximum Load Capacity = 1,800 lbs [815 kg]. See separate instructions about other options.
Operating Elevation:	Maximum = 6,000' [1,828 m]
Operating Temperatures:	32° to 104° F [0° to 40° C]
Service Life:	This lifter is designed to have a service life of 20,000 lifting cycles, when used and maintained as intended. Vacuum pads, filter elements and other wear-out items are excluded; see MAINTENANCE and REPLACEMENT PARTS LIST for more information. For the DISPOSAL OF THE LIFTER after its service life, see INTENDED USE.
ASME Standard BTH-1:	Design Category "B", Service Class "0" (see www.wpg.com for more information)

!!-CE-!! Note: This symbol appears in the *INSTRUCTIONS* manual only when requirements of a CE Standard are *different* from requirements of other standards that also apply to this vacuum lifter. CE requirements are mandatory in geographical areas where CE Standards apply, but may be optional in other locations.

¹ The illustrations under ASSEMBLY: TO CHANGE THE PAD FRAME CONFIGURATION show the Pad Spread and Maximum Load Capacity for all approved MR1611LDC pad frame configurations.

² Load Capacity is based on a friction coefficient of 1; see MAINTENANCE: VACUUM PAD MAINTENANCE: Friction Coefficient for additional information.

WARNINGS



Powr-Grip is pleased to offer the most reliable vacuum lifters available. Despite the high degree of security provided by this product, certain precautions must be observed to protect the operator and others.



Always wear personal protective equipment that is appropriate for the material being handled. Follow trade association guidelines.

Always operate the lifter under conditions approved for its design (see INTENDED USE: OPERATING ENVIRONMENT).

Never operate a lifter that is damaged, malfunctioning, or missing parts.

Never operate a lifter if the sealing edge of any vacuum pad is cut or otherwise damaged.

Never remove or obscure warning labels.

Never operate a lifter if the Maximum Load Capacity or any warning appears to be missing or obscured.

Always make certain the contact surfaces of the load and all vacuum pads are clean prior to attaching the pads (see MAINTENANCE: VACUUM PAD MAINTENANCE).

Never exceed the Maximum Load Capacity or attempt to lift loads that the lifter is not designed for (see INTENDED USE: LOAD CHARACTERISTICS).

Never attempt to lift cracked or broken glass with this lifter.

Always position the vacuum pads correctly on the load prior to lifting (see OPERATION: To ATTACH THE PADS TO A LOAD).

Never lift a load when any vacuum indicator shows inadequate vacuum.

Never touch the vacuum release controls during a lift. This may result in loss of vacuum and release of the load.

Never allow people to ride on the lifter or the load being lifted.

Never lift a load higher than necessary or leave suspended loads unattended.

Never lift a load over people.

Always keep other personnel far enough away from the lifter to avoid injury in the event of an unexpected load release.

Always place the power control in the inactive position and, when possible, disconnect the power source before opening any enclosure on the lifter. (Only applicable to powered lifters)

Always remember that modifications to the lifter could compromise its safety. Wood's Powr-Grip cannot be responsible for the safety of a lifter that has been modified by others. For consultation, contact Wood's Powr-Grip (see LIMITED WARRANTY).

If the lifter is equipped with a Remote Control System, **never** operate the lifter remotely unless there is clear communication about intended actions (eg, releasing load) with all personnel near the lift. In addition, the operator must visually verify the status of the lifter and load prior to remote operations.

OPERATING FEATURES

Note: Components featured in the following instructions for assembling, operating or maintaining the vacuum lifter are underlined on their first appearance in each section.

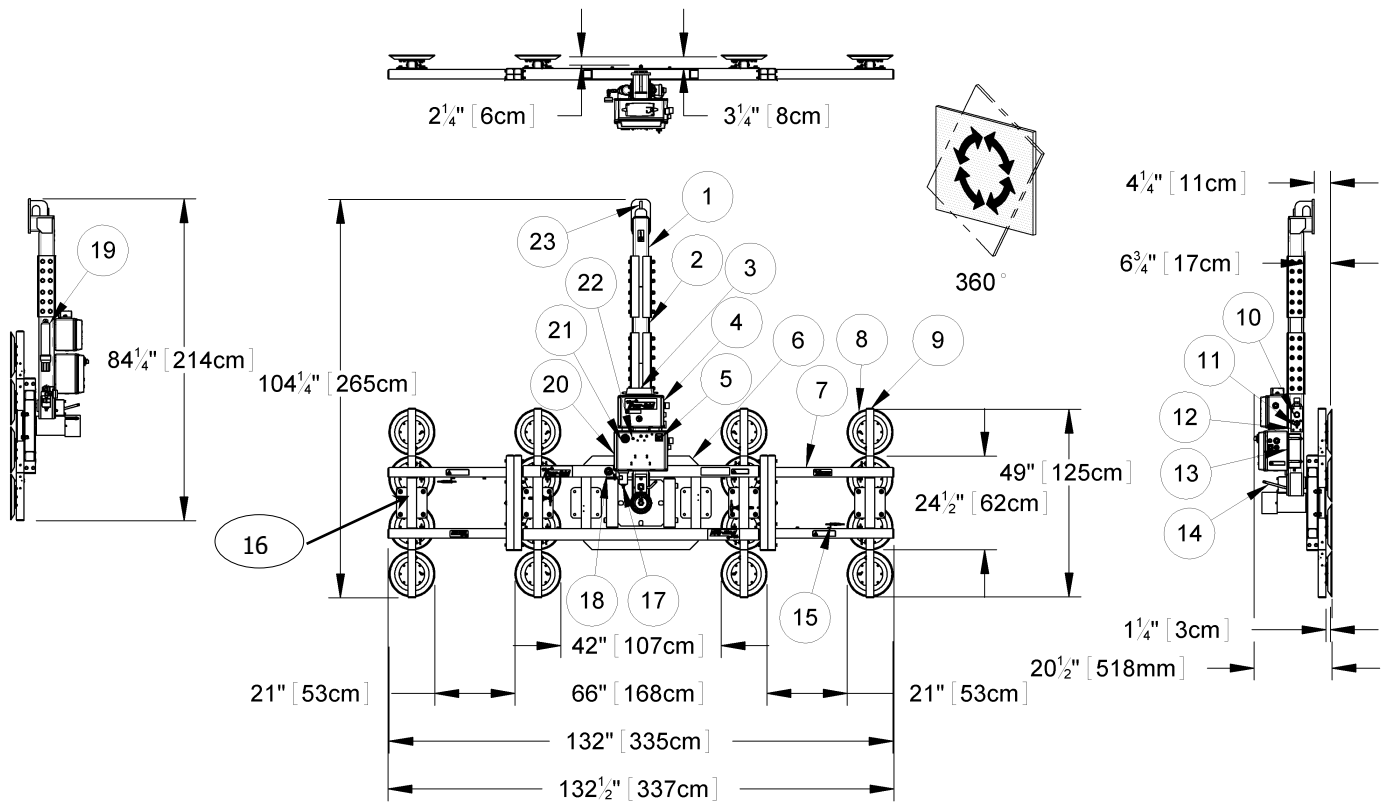

Standard MR1611LDC shown.

- | | |
|----------------------------------|---|
| 1 LIFT BAR | 13 VACUUM RESERVE TANK |
| 2 LIFT BAR EXTENSION | 14 ROTATION RELEASE LEVER |
| 3 BATTERY CHARGER | 15 QUICK CONNECTOR |
| 4 BATTERY ENCLOSURE | 16 ROTATING PAD ARM |
| 5 POWER SWITCH | 17 AIR FILTER |
| 6 CENTER SECTION of PAD FRAME | 18 VACUUM GAUGE |
| 7 REMOVABLE SECTION of PAD FRAME | 19 INSTRUCTION CANISTER |
| 8 VACUUM PAD | 20 Enclosure with VACUUM PUMP(S)
and VACUUM SWITCH |
| 9 REMOVABLE PAD ARM | 21 BATTERY GAUGE |
| 10 VACUUM LIFT LIGHT | 22 BATTERY TEST BUTTON |
| 11 "ATTACH/RELEASE" SWITCH | 23 LIFT BAIL |
| 12 MOVABLE CONTROL PENDANT | |

ASSEMBLY

TO SET UP THE LIFTER

- 1) Open the shipping container and remove all materials for restraining or protecting the vacuum lifter. Save the container for use whenever the lifter is transported.
- 2) Suspend the lifter from a crane as follows: Select hoisting equipment (crane and hoist, when applicable) rated to carry the maximum load weight plus the lifter weight (see SPECIFICATIONS: Maximum Load Capacity and Lifter Weight).

Note: Any application of the lifter must conform to all statutory or regulatory standards that relate to the hoisting equipment when used in its geographical location (eg, relevant OSHA standards in the USA).

Disengage the lifter's rotation latch (see OPERATION: TO ROTATE THE LOAD EDGEWISE) and raise the lift bar to a vertical orientation, until the rotation latch re-engages.

Note: When you are planning to use the removable sections of the pad frame, install the lift bar extension before proceeding further (see TO CHANGE THE PAD FRAME CONFIGURATION to follow).

 **WARNING: Hoisting equipment hook must be fitted with restraining latch to prevent lift bail from slipping off under any circumstances.**

Note: Some hoisting equipment hooks could interfere with an upright load that extends beyond the lifter's pad frame. If the load would contact the hook during lifter operation, the operator must prevent this by attaching a sling (or other rigging that does not interfere with the load) between the hook and the lift bail.

 **WARNING: Any sling used must be rated to carry maximum load weight plus lifter weight.**

Attach the hoisting equipment hook to the lift bail, and use the hoisting equipment to raise the lifter out of the shipping container. Be careful to avoid damaging any vacuum pads. Remove the pad covers and save them for use whenever the lifter is stored.

- 3) Assemble the pad frame in the configuration that will provide optimal support of the load while lifting (see TO CHANGE THE PAD FRAME CONFIGURATIONS to follow).
- 4) Connect the electrical connectors uniting the battery to the battery charger and the vacuum generating system. Now the lifter is operational.
- 5) Perform Operational and Load Tests for the lifter as directed in MAINTENANCE: TESTING SCHEDULE. If the lifter is equipped with a Remote Control System, also perform the REMOTE CONTROL SYSTEM TEST (see MAINTENANCE).

TO CHANGE THE PAD FRAME CONFIGURATION

Various pad frame configurations enable the lifter to match different load dimensions and weights. The following illustrations show all approved pad frame configurations.

⚠ Use only approved pad frame configurations.

1) Choose the approved configuration that will maximize support across the load surface and minimize load overhang (see INTENDED USE: LOAD CHARACTERISTICS).

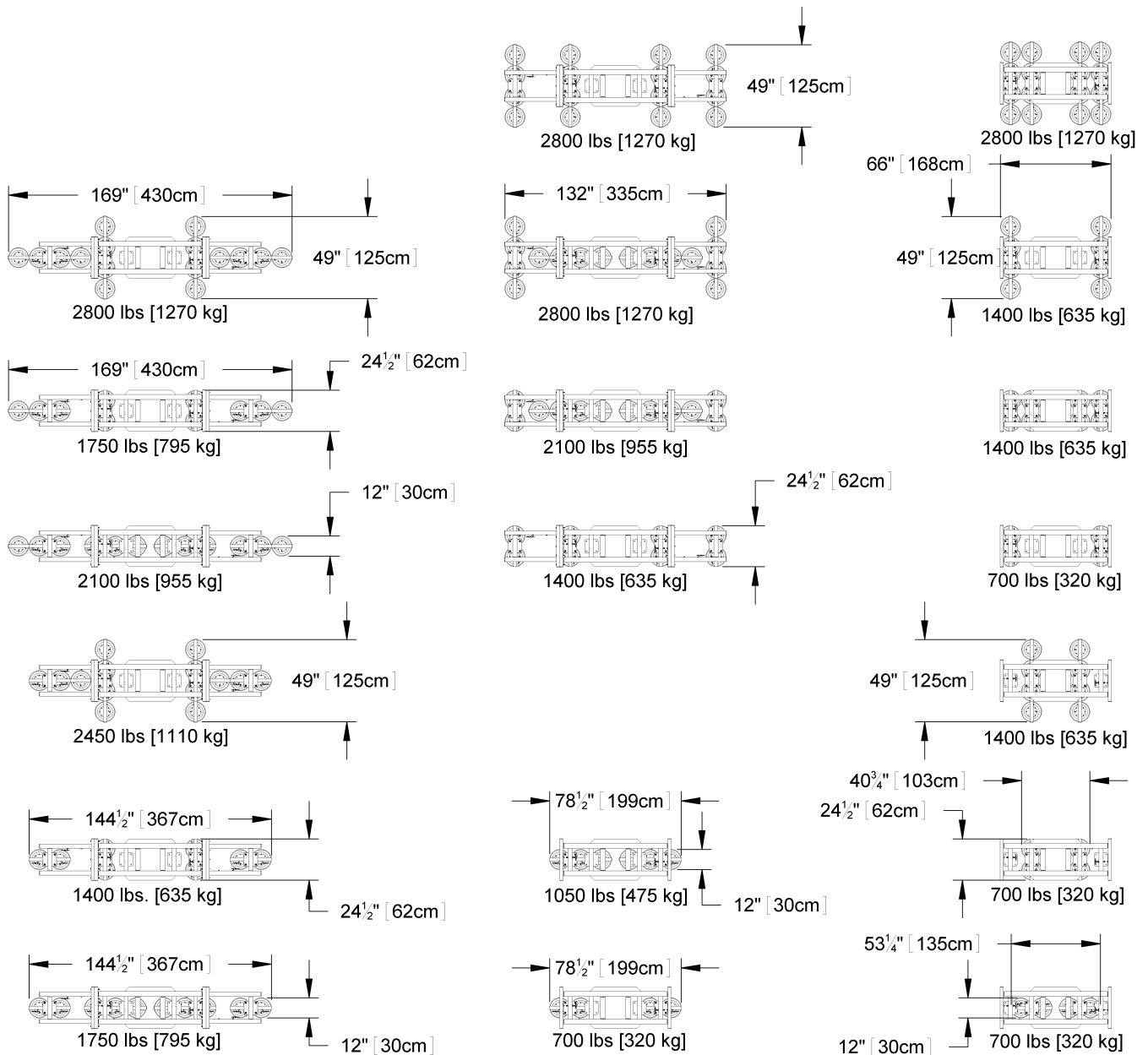

2) Install or remove the pad frame's removable sections and removable pad arms, and/or rotate the rotating pad arms, as needed. Some configurations also require the lift bar extension (see sections to follow.)

⚠ Securely position vacuum hoses to avoid damage during lifter operation.

⚠ Make sure quick connectors seal completely and all vacuum hoses function correctly.

To Install (and Remove) the Lift Bar Extension

The lift bar extension must be used whenever the pad frame's removable sections are attached. Otherwise, the extended pad frame would strike the lift bail during rotation. The lift bar extension can be removed whenever the removable sections are not attached to the pad frame.

- 1) Support the lifter so that hoisting equipment is not required to hold it upright. Make sure the lifter is supported securely before removing the hoisting equipment hook from the lift bail.
- 2) Remove the 12 bolts from the lift bar joint and remove the joint couplers.
- 3) Install the lift bar extension between the upper and lower sections of the lift bar.
- 4) Install joint couplers at the joints on either end of the lift bar extension.
- 5) Install and securely tighten the 12 bolts for each of the 2 lift bar joints.
- 6) To remove the lift bar extension, reverse this procedure.

To Install (and Remove) the Optional Short Lift Bar

If applicable, install the Short Lift Bar directly to the lifter, as described in the preceding section. However, do *not* use the lift bar extension or joint couplers; instead, bolt the Short Lift Bar securely onto the lower section of the standard lift bar, using the hardware provided.

⚠ WARNING: Maximum Load Capacity equals 1,800 lbs [815 kg] when Short Lift Bar is installed.

To remove the Short Lift Bar, reverse this procedure.

To Install (and Remove) the Removable Sections of the Pad Frame

- 1) Align one removable section with the center section of the pad frame.
- 2) Align the bolt holes on each side of the joint where the removable section attaches to the center section. Insert the 8 bolts for 1 removable section through the bolt holes and tighten the bolts securely. Make sure the bolt spacers located inside the pad frame's tubes remain in place.
- 3) Remove the male end of the quick connector from the spring clip on the pad frame's removable section. Thread the vacuum hose through the opening for this purpose at the pad frame joint. Push the male and female ends of the quick connector together until they lock.
- 4) Repeat steps 1-3 to install the other removable section of the pad frame.
- 5) To remove the pad frame's removable sections, reverse this procedure. Move the release ring on the female end of the quick connector away from the male end to separate the ends.

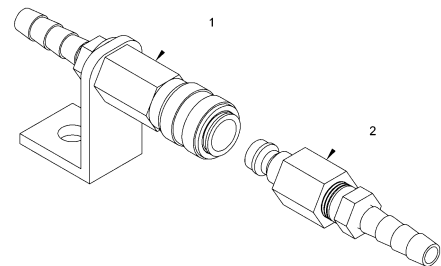

QUICK CONNECTOR

- 1) FEMALE END
- 2) MALE END

To Install (and Remove) Removable Pad Arms

- 1) Insert the end of a removable pad arm in one socket on the pad frame, so that the holes align for the cotterless hitch pin.
- 2) Secure the removable pad arm in the pad frame by pushing a cotterless hitch pin through the holes until the retaining ball emerges on the far side of the pad frame socket.
- 3) Remove the end of the quick connector from the spring clip on the pad arm. Push the male and female ends of the quick connector together until they lock.
- 4) Repeat steps 1-3 to install each pad arm required for the pad frame configuration desired.
- 5) To remove the removable pad arms, reverse this procedure. Move the release ring on the female end of the quick connector away from the male end to separate the ends. Store removed pad arms in a clean, dry location to protect them from environmental exposure.

To Rotate Rotating Pad Arms

- 1) Remove the 4 bolts that secure each rotating pad arm on the pad frame.
- 2) Rotate the arm 90° and reinstall the bolts.
- 3) Repeat steps 1-2 to rotate each pad arm as required for the pad frame configuration desired.

INTENDED USE

LOAD CHARACTERISTICS

 **WARNING: This lifter is NOT intended for lifting hazardous materials, such as explosives or radioactive substances.**

The operator must verify that the lifter is intended to handle each load, in accordance with the following requirements:

- The load must not exceed the maximum allowable weight specified under Load Capacity (see SPECIFICATIONS).
- The load must be a single piece of nonporous or semiporous material with a flat and relatively smooth contact surface.³ To determine whether the load is too porous or rough, perform the test under Vacuum Level on Other Surfaces (see OPERATION: TO ATTACH THE PADS TO A LOAD).
- The load's contact surface must be suitable for obtaining a friction coefficient of 1 with the lifter's vacuum pads (see MAINTENANCE: VACUUM PAD MAINTENANCE: Friction Coefficient), as verified by a friction test, or capacity should be derated appropriately. If necessary, contact Wood's Powr-Grip for help in conducting a friction test.
- In order to avoid damaging the vacuum pads, the load's surface temperature must not exceed the allowable Operating Temperatures (see SPECIFICATIONS). However, if such an application cannot be avoided, Wood's Powr-Grip does offer a heat-resistant rubber compound and other solutions that may enable you to lift loads with higher surface temperatures. Contact Wood's Powr-Grip or an authorized dealer for more information.
- While the *minimum* length and width of the load are determined by the Pad Spread (see SPECIFICATIONS), the *maximum* length and width are determined by the allowable overhang, or the amount of load material that can extend sideways beyond the vacuum pads without breaking or otherwise being damaged.

The allowable overhang depends on the kind of load material being lifted, the thickness of the material, and the angle at which it is handled (if any). Since materials such as glass, stone or sheet metal each have different physical properties, the allowable overhang must be evaluated separately for each type of load. If necessary, contact Wood's Powr-Grip or an authorized dealer for help in determining the recommended overhang in a specific situation.

- 1" [2.5 cm] is the maximum allowable thickness of loads at the maximum weight (see SPECIFICATIONS: Maximum Load Capacity). However, allowable thickness increases as load weight decreases. If necessary, contact Wood's Powr-Grip for help in determining the maximum thickness permitted when handling any specific load.

Note: Vacuum pads can stain or deform load surfaces with light colors or soft coatings. The operator should test such surfaces for detrimental effects before using the lifter on them.

³ Lifters that feature concave vacuum pads can also attach to some kinds of curved loads. Since curvature affects the lifting capacity, contact WPG for help in determining the Maximum Load Capacity for a particular curved load.

OPERATING ENVIRONMENT

The operator must determine whether the lifter is intended to be used in each work environment, in accordance with the following restrictions:

 **WARNING: Never use lifter in dangerous environments.**

- This lifter is not intended for use in any environment that is inherently dangerous to the operator or likely to compromise the lifter's ability to function. Environments containing explosives, caustic chemicals and other dangerous substances must be avoided when using the lifter.
- The lifter's work environment is limited by the Operating Elevation and Operating Temperatures indicated in SPECIFICATIONS.
- The lifter's work environment must be free of metal particles or any other contaminants that could damage lifter components through airborne contact or any other means of transmission in the environment. If such contaminants cause a vacuum pump failure, they could result in a load release and injury to the operator or others nearby.

 **WARNING: Environmental contaminants could result in vacuum pump failure.**

- Using the lifter in wet environments may require the operator to take special precautions: Moisture on contact surfaces of the load or vacuum pads diminishes the lifter's slip resistance, thereby reducing the lifting capacity (see MAINTENANCE: VACUUM PAD MAINTENANCE: Friction Coefficient).

 **WARNING: Moisture reduces slip resistance of vacuum pads.**

Although the lifter's exterior surfaces can tolerate some exposure to water vapor, they are not designed to be watertight. Submerging the lifter or using it in rain may damage lifter components; these and similar conditions must be avoided.

- If the lifter is equipped with a Remote Control System, the work environment must be suitable for using it, as verified by the REMOTE CONTROL SYSTEM TEST (see MAINTENANCE).

- =====
- **!!-CE-!!** If the lifter is employed in a construction area, CE Standard EN 13155 requires the use of a secondary positive holding device, such as a sling system, designed to support the load in case of a vacuum system failure.

 **WARNING: Where CE Standards apply, secondary positive holding device is required for lifting loads in construction zones.**

=====

DISPOSAL OF THE LIFTER

After the vacuum lifter has reached the end of its service life, you must dispose of the lifter in compliance with all local codes and regulatory standards that are relevant for the geographical region.

Note: This lifter is equipped with a battery, which may be subject to special disposal regulations.

OPERATION

BEFORE USING THE LIFTER

The operator must determine whether the lifter is capable of performing each intended task, in accordance with the SPECIFICATIONS and INTENDED USE sections of this *INSTRUCTIONS* manual. In addition, all of the following preparations must be completed prior to lifting any load.

Taking Safety Precautions

The operator must be trained in all relevant industry and regulatory standards for the operation of the vacuum lifter in its geographical location (eg, ASME B30.20 in the USA).

The operator must read and understand this *INSTRUCTIONS* manual, including all **WARNINGS**, before using the lifter. If necessary, contact Wood's Powr-Grip or an authorized dealer for assistance.

⚠ WARNING: Always wear appropriate personal protective equipment.

The operator must wear any personal protective equipment and take any other precautions required to handle the load safely. Consult appropriate trade association guidelines to determine what precautions are necessary for each type of load material.

Performing Inspections and Tests

⚠ WARNING: Always check battery energy before using lifter.

(See MAINTENANCE: BATTERY TEST)

Perform all inspections and tests required by the INSPECTION and TESTING SCHEDULES (see MAINTENANCE). In addition, if the lifter has been in storage, always conduct a VACUUM TEST before placing it in service (see MAINTENANCE).

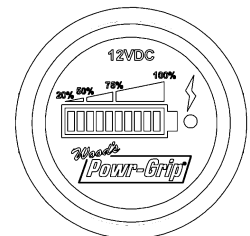

⚠ WARNING: Make sure alarm is clearly audible over ambient noise at operator position.

If the lifter is equipped with a low vacuum warning buzzer, the volume of the alarm may be adjusted by rotating the shutter of the warning buzzer. Make sure the alarm is loud enough to be heard over any other noise that may be present while the lifter is in use. In addition, the alarm must be clearly audible at the maximum distance the operator may be from the lifter, as well as through any barriers or obstructions between the operator and the lifter.⁴

CAUTION: Examine each air filter regularly, and empty when necessary.

The lifter is equipped with one or more air filters to help protect the vacuum system from contaminants. In order for a filter to function, the operator must empty the filter bowl before enough liquid accumulates to contact any portion of the filter element (see MAINTENANCE: AIR FILTER MAINTENANCE).

⁴ If applicable, consult EN7731 to make sure the buzzer complies with CE Standards.

Confirming the Pad Frame Configuration

⚠ WARNING: Load Capacity of lifter varies, depending on pad frame configuration.

Make sure the pad frame has been assembled in the configuration that will provide optimal support of the load while lifting (see ASSEMBLY: TO CHANGE THE PAD FRAME CONFIGURATION). The pad frame configuration selected must be appropriate both for the weight and for the dimensions of the load to be lifted.

Preparing to Use the Optional Remote Control System

If the lifter is equipped with a Remote Control System, the operator can engage the lifter's "attach" and "release" functions at distances up to 250' [76 m], provided there is a direct and clear view of the lifter and its status indicators from the operator location (see MAINTENANCE: REMOTE CONTROL SYSTEM TEST). When lifting a load from a remote location, the operator must monitor the lifter at all times to make sure that it is functioning as intended.⁵ Additionally, the operator must exercise special care to make sure that the load is landed and supported correctly before releasing the load (see TO RELEASE THE PADS FROM THE LOAD to follow).

The radio transmitter is also equipped with an emergency transmitter disconnect that prevents the transmitter from sending any transmission. To reset, twist the button clockwise while allowing it to spring outward to its normal position.

- 1 EMERGENCY TRANSMITTER DISCONNECT
- 2 TRANSMISSION INDICATOR LIGHT
- 3 "RELEASE" BUTTON
- 4 TRANSMITTER POWER/ENABLE BUTTON
- 5 "ATTACH" BUTTON



⁵ The Remote Control System is designed with safeguards to prevent multiple lifters from responding until a clear transmission is received. Nevertheless, radio controlled lifters should be tested to make sure that each transmitter controls only one lifter. The buttons located on the lifter function regardless of any radio transmissions in the vicinity.

TO ATTACH THE PADS TO A LOAD

Powering up the Lifter

Place the lifter's power switch in the "on" position ().⁶ The blue power light remains illuminated while the lifter is powered up. Keep the power switch in the "on" position while lifting a load. Any power interruption during a lift could result in the release of a load and injury to the operator or others (see TO LIFT AND MOVE THE LOAD: In Case of Power Failure to follow).



WARNING: Never turn power off while lifting.



If the lifter is equipped with a Remote Control System, press the transmitter power () as shown and hold it briefly to activate the radio transmitter.⁷

Note: If the transmitter is activated, the transmission indicator light flashes green when any button on the transmitter is pressed and held; if the transmitter is not activated, the indicator light flashes red (see BEFORE USING THE LIFTER: Preparing to Use the Optional Remote Control preceding).



Positioning the Lifter on the Load

Make certain that the contact surfaces of the load and all vacuum pads are free of any contaminants that could prevent the pads from sealing against the load (see MAINTENANCE: VACUUM PAD MAINTENANCE).

The lifter must be attached only to vertically oriented loads. Center the pad frame to within 2" [5 cm] of the load center, since off-center loading can cause the load to rotate unexpectedly (see TO ROTATE THE LOAD EDGEWISE to follow) and possibly damage the lifter.⁸ Make sure that all vacuum pads will fit entirely on the load's contact surface (see SPECIFICATIONS: Pad Spread) and that they will be loaded evenly while lifting (see SPECIFICATIONS: Per-Pad Load Capacity). Then position the lifter so that all pads are in contact with the load.

⁶ When the operator powers up the lifter, either the stand-by function or the "attach" function is automatically activated, depending on which was used last. If a vacuum pump or any other powered component fails to function while the lifter's power switch is in the "on" position, examine each circuit breaker (adjacent to power switch) to determine whether it has interrupted the electrical circuit to the component. Although the operator can reset the circuit breaker, the power interruption may indicate an electrical problem that requires attention. Correct any deficiency before resuming normal operation of the lifter (see wiring diagram provided).

⁷ The radio transmitter turns off automatically, after a period of inactivity. The operator can also operate the lifter without using the radio transmitter, if desired.

⁸ The lifter is designed to handle the maximum load weight (see SPECIFICATIONS: Maximum Load Capacity) when the load's center of gravity is positioned within 2" [5 cm] of the pad frame's center point. Occasional loading deviations are permissible, if the operator can maintain control of the load at all times *and* the load weight is low enough to avoid damaging the lifter.

Sealing the Pads against the Load

The "attach/release" switch is located on the movable control pendant. The pendant allows the vacuum controls to be moved away from the lifter, so that the operator can control airflow at a distance equal to the length of the pendant cord.

 **WARNING: Do not disconnect control pendant during lifter operation.**

The control pendant is not intended to be disconnected during lifter operation. Disconnecting the control pendant is likely to result in a load release and injury to the operator or others nearby.

Turn the "attach/release" switch to the "attach" (⌚) position (clockwise) to make sure the "attach" function is activated.

 **WARNING: Keep "attach/release" switch in "attach" position throughout lift.**

Alternatively, if the lifter is equipped with a Remote Control System, press the "attach" button (⌚) on the radio transmitter.

This energizes the vacuum pumps, causing air to be drawn immediately at the vacuum pads. The low vacuum warning buzzer also sounds an alarm until the lifter attains sufficient vacuum to lift the maximum load weight (see TO LIFT AND MOVE THE LOAD: Load Capacity and Lift Light to follow). Press the lifter onto the load until all the pads seal against it. The lifter must remain in the "attach" mode throughout the entire lift.

Note: If a vacuum pad has been lying against a hard object (as during shipping), it may be slightly distorted. Although initially it may be difficult to attach the pad to a load, this condition should correct itself with continued use.

Reading the Vacuum Gauge

The vacuum gauge indicates the current vacuum level in the lifter's vacuum system. The *green* range indicates vacuum levels sufficient for lifting the maximum load weight, whereas the *red* range indicates vacuum levels that are **not** sufficient for lifting the maximum load weight. The gauge needle should show a sudden surge in vacuum as the vacuum pads seal against the load. If it takes more than 5 seconds for the vacuum level to reach 5" Hg [-17 kPa], press on any pad that has not yet sealed.

Vacuum Level on Optimal Surfaces

When the lifter is attached to clean, smooth, nonporous load surfaces, it should be able to maintain a vacuum level in the green range on the vacuum gauge, except when used at high elevations (see SPECIFICATIONS: Operating Elevation). If not, make sure the vacuum switch is adjusted correctly (see MAINTENANCE: VACUUM SWITCH ADJUSTMENT). If the vacuum switch cannot be adjusted to maintain a vacuum of 16" Hg [-54 kPa], perform the VACUUM TEST (see MAINTENANCE) to determine whether there is a deficiency in the vacuum generating system.

Vacuum Level on Other Surfaces

When the lifter is attached to contaminated, rough or porous load surfaces, it may not be able to maintain a vacuum level in the green range on the vacuum gauge, due to leakage in the seal between the vacuum pads and the load surface.⁹ In the case of contamination, thoroughly clean the contact surfaces of the load and the vacuum pads (see MAINTENANCE: VACUUM PAD MAINTENANCE: Cleaning), and reattach the lifter to the load. If the load has rough or porous surfaces, ***the operator must conduct a test to determine whether the lifter is designed to lift the load***, as follows:

- 1) Make sure the lifter's vacuum generating system is functioning correctly (see MAINTENANCE: VACUUM TEST).
- 2) Attach the vacuum pads to the load as previously directed.
- 3) After the vacuum pumps stop running, place the power switch in the "off" () position.
- 4) Raise the load a minimal distance, to confirm that it is supported by the lifter.
- 5) Monitor the vacuum gauge while the load is suspended for 5 minutes: ***The lifter must maintain a minimum vacuum level of 10" Hg [-34 kPa] during this time.*** If not, the load does not possess the characteristics required for use with this lifter.¹⁰

⁹ Contaminated loads can also cause the vacuum pumps to run frequently or continuously. Since excessive pumping quickly reduces battery energy, the operator should clean the load when possible, to minimize pumping.

¹⁰ Certain load materials are too rough or porous to allow the vacuum pads to form a seal that can be maintained for 5 minutes without power. However, in geographical locations where CE Standards do not apply, it may be possible to use the lifter to lift such loads. Contact Wood's Powr-Grip for more information.

TO LIFT AND MOVE THE LOAD



WARNING: *Never attempt to lift load when lifter is in horizontal orientation.*

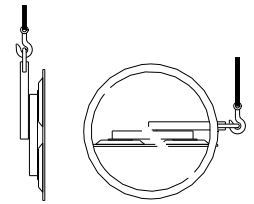

Load Capacity and the Lift Light

A lifter's Load Capacity is rated at a vacuum level of 16" Hg [-54 kPa] (see SPECIFICATIONS). After the lifter has attained this level, the vacuum pumps turn off automatically, to conserve battery energy. At the same time, the green vacuum lift light turns on, to indicate that the lifter is ready to lift the maximum load weight.



WARNING: *Never attempt to lift load unless green lift light is illuminated.*

Do not attempt to lift the load unless the lift light is illuminated; such an attempt could result in a load release and injury to the operator.

Monitoring Vacuum Indicators

The vacuum lift light and the vacuum gauge must remain completely visible to the operator, so that they can be monitored throughout the entire lift.



WARNING: *Vacuum indicators must be visible to operator throughout entire lift.*

If the vacuum system experiences leakage while the lifter is attached to the load, the vacuum pumps turn *on* automatically, as required to maintain sufficient vacuum for lifting the maximum load weight. The lift light turns *off* while the pumps are running, to signal the reduction in vacuum to the operator.

If the pumps turn on and the lift light turns off while you are lifting a load, make sure the vacuum gauge shows a vacuum level of 16" Hg [-54 kPa] or higher. If not, move away and stay clear of the load until it can be lowered to the ground or a stable support.



WARNING: *Stay clear of any suspended load when vacuum level is insufficient.*

Discontinue lifter use until the cause of the vacuum loss can be determined. If the pumps run at intervals of 10 minutes or less while the lifter is attached to clean, smooth, nonporous materials, the leakage is likely to be in the vacuum system. In this event, perform the VACUUM TEST (see MAINTENANCE) and inspect the vacuum pads for damage (see MAINTENANCE: VACUUM PAD MAINTENANCE: Inspection). If the vacuum loss cannot be remedied immediately, perform inspections and maintenance as needed to identify and correct any deficiency before resuming normal operation of the lifter.

Monitoring the Low Vacuum Warning Buzzer (if applicable)

If the lifter is equipped with a low vacuum warning buzzer, an alarm sounds until the lifter attains sufficient vacuum to lift the maximum load weight (see SPECIFICATIONS: Load Capacity). After the lifter has attained this vacuum level, the alarm stops sounding, to indicate that the lifter is ready to lift the load.

 **WARNING: Never attempt to lift load while alarm is sounding.**

Do not attempt to lift the load while the alarm is sounding; such an attempt could result in a load release and injury to the operator.

If the vacuum system experiences leakage while the lifter is attached to the load, the vacuum pumps turn on automatically, as required to maintain sufficient vacuum. The alarm also sounds while the pumps are running, to signal the reduction in vacuum to the operator. If the alarm sounds while you are lifting a load, make sure the vacuum gauge shows a vacuum level of 16" Hg [-54 kPa] or higher. If not, immediately move away and stay clear of the load until it can be lowered to the ground or a stable support.

 **WARNING: Stay clear of any suspended load while alarm is sounding.**

Discontinue lifter use until the cause of the vacuum loss can be determined. Using the lifter on contaminated, rough or porous surfaces may result in a vacuum loss, due to leakage between the vacuum pads and the load. Since the alarm may sound in such circumstances, consult the section TO ATTACH THE PADS TO A LOAD: Vacuum Level on Other Surfaces to determine whether the lifter can be used to lift the load. If the vacuum loss is due to any other cause, perform inspection and maintenance as needed to identify and correct any deficiency before resuming normal operation of the lifter.

Controlling the Lifter and Load

When vacuum indicators show that the lifter is ready, use the hoisting equipment to raise the lifter and load as needed to clear any obstacles in their path. Use any appropriate means to keep the lifter and load in the desired orientation while they are suspended from the crane. Once sufficient clearance is established, the load can be rotated as desired (see TO ROTATE THE LOAD EDGEWISE to follow).

In Case of Power Failure

The lifter is equipped with a vacuum reserve tank, designed to maintain vacuum temporarily in case of a power failure (ie, in battery).

 **WARNING: Stay clear of any suspended load in the event of a power failure.**

Although the lifter is designed to support the load for at least 5 minutes without power, this depends on many factors, including the condition of the load and the lifter's vacuum system (see INTENDED USE: LOAD CHARACTERISTICS and MAINTENANCE: VACUUM PAD MAINTENANCE, VACUUM TEST). If a power failure occurs, keep everyone clear of the suspended load until it can safely be placed on the ground or a stable support. Correct any deficiency before resuming normal operation of the lifter.

To ROTATE THE LOAD

⚠ WARNING: *Make sure load is positioned correctly on lifter (see To ATTACH THE PADS TO A LOAD); unbalanced loads may rotate unexpectedly when latch is disengaged.*

Remember that the load is longer in its diagonal dimensions than in its side dimensions. Make sure there is sufficient clearance for the load to rotate without contacting the operator or any nearby objects. Keep the load under control at all times, using hand cups or other appropriate means.

Disengaging the pad frame's rotation latch allows the load to rotate. Pull the cable that hangs from the rotation release lever to disengage the rotation latch, and rotate the load to the desired position.

To stop the load's motion automatically at each quarter turn, simply let go of the cable immediately after initiating the rotation, so that the rotation latch engages at the next stop. Whenever rotation is not required, keep the rotation latch engaged, to prevent accidental damage to the load and possible injury to the operator.

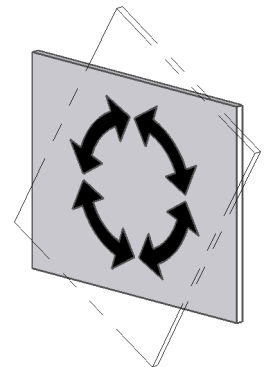

TO RELEASE THE PADS FROM THE LOAD

 **WARNING: Load must be fully supported before releasing vacuum pads.**

Make sure the load is at rest and fully supported. Then turn the “attach/release” switch on the movable control pendant to the “release” (⇄) position (counter-clockwise) to force air into the vacuum pads, quickly breaking the vacuum seal. Continue to hold the “attach/release” switch in this position until the pads disengage completely from the load.

When the “attach/release” switch is no longer held in the “release” (⇄) position, it automatically returns to the neutral position (stand-by mode). Do not turn the “attach/release” switch to the “attach” (⇄) position until the pads are contacting the next load to be lifted. This conserves battery energy and reduces the time required to attach the pads to the load, by preventing the vacuum reserve tank from losing its vacuum.

Alternatively, if the lifter is equipped with a Remote Control System, press and hold the “enable” button () and the “release” button (⇄) on the radio transmitter to force air into the vacuum pads, quickly breaking the vacuum seal.¹¹ Continue to hold both buttons until the vacuum pads disengage completely from the load.

Note: If the lifter is equipped with a Remote Control System, the strobe light flashes as long as the operator is pressing the “enable” or “release” buttons. This shows the operator when signals are being transmitted successfully from a remote location and warns others that the operator is preparing to release the load.

 **WARNING: If vacuum pads do not disengage completely, do not attempt to move the lifter or load.**

The operator must never attempt to move the lifter or load until the vacuum pads are completely disengaged, as this could cause an unexpected load release and injury to the operator or others.

If the vacuum pads do not disengage completely on the first attempt, repeat the release process. If the load cannot be successfully released for any reason, reattach the vacuum pads to the load as previously directed (see TO ATTACH THE PADS TO A LOAD preceding) prior to moving the lifter or load.

After the load is successfully released, the lifter will automatically activate the stand-by mode to conserve the battery energy until the lifter is ready to lift another load. Once the stand-by mode is activated, only the blue power light remains illuminated.

Prior to lifting another load, perform the Every-Lift Inspection as directed in MAINTENANCE: INSPECTION SCHEDULE.

¹¹ The radio transmitter must be activated before the enable function can be used (see TO ATTACH THE PADS TO A LOAD: Powering Up the Lifter).

AFTER USING THE LIFTER

Leave the “attach/release” switch in the neutral position and place the power switch in the “off” position (⊖). The blue indicator light shuts off when the operator powers down the lifter.

CAUTION: Do not set the lifter against any surfaces which could soil or damage the vacuum pads.

Built-in parking feet can be used to support an unloaded lifter that is not suspended from a crane: Make sure the pad frame is oriented vertically with the parking feet at the bottom (see OPERATING FEATURES orientation). Use the hoisting equipment to gently lower the lifter until the parking feet support its entire weight. Make sure the lifter leans securely against an appropriate support; then detach the hoisting equipment hook from the lift bail.

If the lifter is transported to another location, use the original shipping container and secure the lifter, to protect the vacuum pads and all other components from damage while in transit.

Storing the Lifter

Use the covers supplied to keep the vacuum pads clean.

~~~~~  
**!!-CE-!!** In accordance with CE Standard EN 13155, the lifter is designed to rest on relatively horizontal surfaces without tipping over. To store the lifter in this way, set the lifter with the pads facing downward on a clean, smooth, flat surface and place a support under the lift bail. Since the lifter’s intended use does not include tilting, be careful to protect the vacuum pads and support the lifter while tilting it to the horizontal position.  
~~~~~

Charge the battery completely when placing it in storage and at 6-month intervals thereafter (see MAINTENANCE: BATTERY RECHARGE). After charging the battery, disconnect the electrical connectors uniting the battery to the battery charger and to the vacuum generating system, in order to minimize power drainage. Preferred temperatures for storing the battery are 32° to 70° Fahrenheit [0° to 21° Celsius]. Higher temperatures require the battery to be charged more frequently. Storage at temperatures above 100° Fahrenheit [38° Celsius] should be avoided.

MAINTENANCE

 **WARNING:** Always make sure battery is disconnected before servicing lifter.

Note: One or more wiring diagrams are provided in the final section of this *INSTRUCTIONS* manual for reference when servicing the lifter or troubleshooting a deficiency.

INSPECTION SCHEDULE

Perform inspections routinely, according to the following frequency schedule:

Every-Lift Inspection

- Examine the vacuum pads and load surface for contamination or debris (see VACUUM PAD MAINTENANCE to follow).
- Examine the vacuum pads, controls and indicators for visual damage (see VACUUM PAD MAINTENANCE to follow).
- Test the battery for adequate charge (see BATTERY TEST to follow).

If a battery's charge appears to be inadequate, charge and retest the battery (see BATTERY RECHARGE to follow). If any other deficiency is detected during the inspection, correct it before using the lifter and perform the Frequent Inspection to follow.

Frequent Inspection

(following every 20-40 hours' use; or whenever lifter is out of service for 1 month or more)

- Examine the lifter's structure for visual damage.
- Examine the vacuum system (including vacuum pads, fittings and hoses) for visual damage.
- Examine the air filter for conditions requiring service (see AIR FILTER MAINTENANCE to follow).
- Perform the VACUUM TEST to follow.
- Check for unusual vibrations or noises while operating the lifter.
- If the lifter is equipped with a Remote Control System, perform the REMOTE CONTROL SYSTEM TEST to follow.

If any deficiency is detected during the inspection, correct it before using the lifter and perform the Periodic Inspection to follow.

Periodic Inspection

(following every 250-500 hours' use; or whenever lifter is out of service for 1 year or more)

- Examine the entire lifter for external evidence of looseness, excessive wear, deformation, cracks, excessive corrosion, dents to structural or functional components, cuts, or any deficiency which might constitute a hazard.
- Inspect all parts of the electrical system for damage, wear or contamination that could constitute a hazard, in compliance with all local codes and regulatory standards that are relevant for the geographical region.

CAUTION: Be sure to use appropriate cleaning methods for each type of electrical component, as specified by codes and standards. Improper cleaning can damage components.

- Keep a written record of all Periodic Inspections.

If any deficiency is detected during the inspection, correct it before using the lifter. If necessary, return the lifter to Wood's Powr-Grip or an authorized dealer for repair (see LIMITED WARRANTY).

Infrequent Use

If a lifter is used less than 1 day in a 2-week period, perform the Periodic Inspection *each time before using the lifter*.

TESTING SCHEDULE

Perform these tests when placing the lifter in service *initially* and *each time following a repair or modification*. Correct any deficiency and retest before using the lifter.

Operational Tests

- Perform the VACUUM TEST to follow.
- Test all features and functions of the lifter (see OPERATING FEATURES, OPERATION and MAINTENANCE).

Load Test

Confirm that the lifter can lift 100% of its Maximum Load Capacity (see SPECIFICATIONS), using an actual load or an equivalent simulation.¹² Employ the following method to test with an actual load:

- 1) Place a test load with appropriate LOAD CHARACTERISTICS (see INTENDED USE) on a stable support. Make sure the load is oriented in the upright position.¹³
- 2) Attach the vacuum pads to the load as previously directed.
- 3) After the vacuum pump stops running, place the power switch located on the lifter in the "off" (⊖) position.
- 4) Raise the load a minimal distance, to assure that it is supported by the lifter.
- 5) Hold the load for 5 minutes. The load must not slip or fall during this time period. If it does, conduct a VACUUM TEST and inspect each vacuum pad as indicated under VACUUM PAD MAINTENANCE: Inspection (see sections to follow). Correct any deficiency that is found and retest the lifter.

Note: See MAINTENANCE topics to follow for additional directions about inspecting and testing specific lifter components. Since the low vacuum warning buzzer (if applicable) is controlled by a

¹² ASME Standard B30.20 requires the lifter to be tested to 125% of its Load Capacity.

¹³ Flat Lifters are exempt from this requirement.

vacuum switch, consult the VACUUM SWITCH ADJUSTMENT discussion for inspection, testing and adjustment procedures.

MAINTENANCE SCHEDULE

Unless specified elsewhere in this *INSTRUCTIONS* manual, the lifter does not require maintenance on a routine basis. Instead, maintenance must be performed whenever a deficiency is indicated by routine inspections or tests. Any maintenance warranted must be performed before resuming normal operation of the lifter.

BATTERY TEST

The lifter is equipped with a battery gauge to help the operator evaluate whether the battery has adequate energy for lifting. Factors such as the condition of the battery, the time required to execute a lift, and the porosity of the load combine to determine how much battery energy is needed. ***It is the operator's responsibility to evaluate these conditions and to make sure the battery has sufficient energy to complete a lift safely.*** Check the battery energy before every lift and also at the end of each day's use, to decide whether a charge is needed (see BATTERY RECHARGE to follow).¹⁴ Never use the lifter when battery energy registers lower than 50% (that is, when only red lights are illuminated), regardless of the estimated energy requirement.

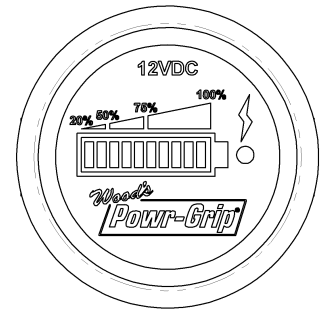

⚠ WARNING: Never use lifter if battery energy is lower than 50% of capacity.

While the lifter's power switch is in the "on" () position and the vacuum system is in stand-by mode (see OPERATION: TO RELEASE THE PADS FROM THE LOAD), the operator must press the battery test button for a few moments to make the energy level register on the battery gauge. This enables the operator to check the battery energy while the lifter is powered up but *not* attached to a load.

While the lifter's power switch is in the "on" () position and the vacuum system is in "attach" mode (see OPERATION: TO ATTACH THE PADS TO A LOAD), the battery gauge automatically monitors the energy level of the battery. This enables the operator to check the battery energy while the lifter is powered up and attached to a load. However, the battery gauge shuts off temporarily while the vacuum pumps are running, to prevent an inaccurate reading. When the pumping cycle is completed, the battery gauge requires a few moments to stabilize before it displays an accurate energy reading again.

Note: If the lifter has not been used since the battery was charged, the battery gauge may falsely indicate an energy level that is higher than actual, due to a "surface charge" on the battery. After the pumps run for approximately one minute, the surface charge dissipates, allowing the operator to take an accurate energy reading.

¹⁴ The battery charger must be disconnected from its AC power source in order to test the battery energy; otherwise, the energy reading on the battery gauge would not be accurate.

BATTERY RECHARGE

CAUTION: Charge battery only while lifter's power switch is in the "off" (☐) position.

Operating the lifter when the battery charger is connected to an AC power source could result in permanent damage to the charger.

Only use a battery charger supplied by or approved by Wood's Powr-Grip; other chargers may reduce battery life. Charge the battery as soon as possible after any extended use of the lifter, or whenever the battery gauge indicates diminished energy (see BATTERY TEST preceding). Temperatures higher than 70° Fahrenheit [21° Celsius] require the battery to be charged more frequently.

Identify the input voltage marked on the charger and plug it in to an appropriate power source.¹⁵ The power source must be equipped with a ground fault circuit interrupter, in order to reduce the risk of electrical shocks.

⚠ WARNING: Power source must be equipped with ground fault circuit interrupter.

Press the "MODE" button to select "NORMAL" mode. After the mode has been selected, the charger should begin to charge the battery automatically. Lights #1-4 in the illustration indicate the level of charging that has been attained.¹⁶ When the battery is fully charged, the charger switches to a maintenance mode and charging level light #4 (green) turns on. The blue light on the battery gauge also turns on, to indicate that the battery is fully charged. Be sure to unplug the charger and check the battery energy again before operating the lifter (see BATTERY TEST preceding).

When the lifter and its charger are used as directed, the battery should take no more than 8 hours to charge completely.¹⁷ However, following long-term use, a battery gradually loses the capacity to hold a charge. After reaching charging level #3, the charger analyzes the battery voltage, to determine whether or not the battery is holding a charge. If the battery does not hold a charge adequately, the charger's red error light (!) turns on, indicating that the battery needs to be replaced (see REPLACEMENT PARTS LIST).

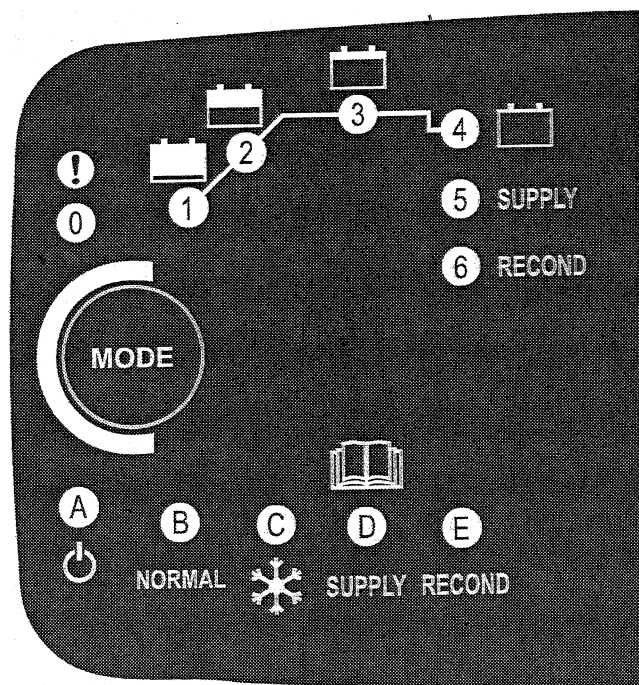

¹⁵ Any external power supply must conform to all applicable local codes.

¹⁶ If none of the charging level lights turns on, the battery connection or the battery itself may be faulty. If the red error light (!) turns on immediately, the battery leads may be reversed or the charger terminals may be short-circuited; once the problem has been corrected, the charger should function normally. The red error light can indicate other problems, depending on the mode selected and level of charging; if necessary, contact Wood's Powr-Grip for assistance.

¹⁷ The charger is designed to automatically sense the energy level of the battery and reduce the charging rate when the battery is fully charged. Accordingly, the charger does not need to be unplugged until the lifter is going to be used again.

VACUUM PAD MAINTENANCE

Friction Coefficient

The friction coefficient represents the lifter's ability to resist load slippage when the load is oriented in any position except horizontal. If the contact surfaces of either the load or the vacuum pads are not clean, dry and in good condition, slippage is more likely to occur.

The Load Capacity of most Powr-Grip lifters is based on a friction coefficient of 1 (only Flat Lifters are exempt from this requirement). However, a vacuum pad's ability to maintain this friction coefficient is reduced by factors such as contamination, wear, age and exposure to sunlight, as well as the condition of the load's contact surface (see INTENDED USE: LOAD CHARACTERISTICS). Pads that have surface contamination must be thoroughly cleaned (see Cleaning discussion to follow). Over time, the rubber in a pad may experience hardening or leaching of chemicals, resulting in stiffness or surface glaze. Pads that exhibit wear, stiffness or glaze must be replaced. In addition, all pads should be replaced on a regular basis, preferably after no more than 2 years, to ensure that the friction coefficient is not compromised. If necessary, contact your dealer or Wood's Powr-Grip for more information.

Inspection

Inspect each vacuum pad for the following deficiencies routinely, as directed in the preceding INSPECTION and TESTING SCHEDULES. Correct any deficiency before using the lifter.

- Contaminates on the pad face or sealing edges: Soil build-up can prevent pads from sealing adequately or reduce the friction coefficient (see discussion preceding). Follow the directions to clean pads as necessary (see discussion to follow).
- Filter screen missing from pad face: This screen helps prevent debris from plugging the vacuum hose and the air filter. Replace any missing screen immediately (see REPLACEMENT PARTS LIST).
- Nicks, cuts or abrasions in sealing edges: Pad damage can reduce the lifting capacity. Replace any damaged pad immediately (see REPLACEMENT PARTS LIST).

 **WARNING: Replace vacuum pad if sealing edge has any nicks, cuts or abrasions.**

- Wear, stiffness or glaze: See Friction Coefficient preceding. Replace any pad that exhibits wear, stiffness or glaze (see REPLACEMENT PARTS LIST).

Cleaning

Regularly clean the face of each vacuum pad to remove oil, dust and any other contaminants. Acceptable cleaning agents include soapy water and other mild cleansers. Do *not* use solvents, petroleum-based products (including kerosene, gasoline and diesel fuel) or any harsh chemicals for cleaning. Do *not* use unauthorized rubber cleaners or conditioners, such as those intended for cleaning tires or vinyl surfaces, because those products can leave a hazardous film on vacuum pads which significantly reduces their lifting capacity (see Friction Coefficient preceding). The use of any unauthorized cleaning agent is prohibited because it could damage the pad and/or create a hazard to the operator or others.

 **WARNING: Never use solvents, gasoline or other harsh chemicals to clean vacuum pad.**

 **WARNING: Never use unauthorized rubber cleaners or conditioners to clean vacuum pad.**

To prevent liquid from contaminating the vacuum system during cleaning, cover the suction hole in the recess for the filter screen or make sure the pad faces downward. Use a clean sponge or lint-free cloth to apply an authorized cleanser and wipe the pad face clean. A toothbrush (or similar brush with bristles *that do not harm rubber*) may be used to remove contaminants clinging to sealing edges.¹⁸ Wipe all residue from the pad face, and allow the pad to dry completely before using the lifter.

VACUUM TEST

Test the vacuum system for leakage routinely, as directed in the preceding INSPECTION and TESTING SCHEDULES.

- 1) Clean the face of each vacuum pad as previously directed (see VACUUM PAD MAINTENANCE: Cleaning).
- 2) Attach the lifter to a clean, smooth, nonporous surface. The surface should be flat or possess no more curvature than the lifter is designed for (if any).¹⁹ When the pumping cycle is completed, the vacuum level should register above 16" Hg [-54 kPa] on the vacuum gauge (if not, see VACUUM SWITCH ADJUSTMENT to follow).
- 3) After the vacuum pumps stop running, leave the pads attached to the surface and place the power switch located on the lifter in the "off" (⊖) position, to interrupt the energy flow from the battery.
- 4) Monitor the vacuum gauge: *The vacuum level should not decrease by more than 4" Hg [-14 kPa] in 10 minutes.*

 **WARNING: If lifter fails vacuum test, discontinue use immediately.**

Correct any deficiency in the vacuum system before using the lifter. Contact Wood's Powr-Grip or an authorized dealer for assistance.

¹⁸ If these cleaning methods are not successful, contact Wood's Powr-Grip or an authorized dealer for assistance.

¹⁹ Any test material used must be fully and independently supported, and capable of bearing the lifter's weight. Do not use the lifter to lift the test material during the vacuum test.

REMOTE CONTROL SYSTEM TEST

If the lifter is equipped with a Remote Control System, perform this test in the environment where the lifter is normally employed. Use the radio transmitter to activate each of the remote functions.²⁰ Vary the location and distance of the transmitter in relation to the lifter, to ensure that transmissions are effective in a variety of circumstances. This may require assistance from someone near the lifter, to verify that functions are being performed as intended.

If the Remote Control System does not function correctly, review the following potential causes of malfunction and correct them as directed:

- The battery for the radio transmitter may be worn out. Replace any expended battery (see REPLACEMENT PARTS LIST).
- Metal or other electrically conductive surfaces may be causing interference between the radio transmitter and radio receiver. Although the transmission signals often can bounce around interfering surfaces, the signals do not travel through conductive walls. Reposition the transmitter as necessary to transmit signals effectively.

If the preceding directions do not resolve a performance problem, repeat the test under different conditions, to determine whether there is transmission interference in the work environment or the Remote Control System is not functioning as intended. Correct any deficiency before resuming normal use of the Remote Control System. If necessary, contact Wood's Powr-Grip or an authorized dealer for assistance.

²⁰ Use a test material with appropriate surface characteristics (see INTENDED USE: LOAD CHARACTERISTICS) to test the "attach" and "release" functions.

AIR FILTER MAINTENANCE – LARGE

(For 4.4 oz bowl size filters)

Filter Function and Conditions Requiring Service

An air filter prevents solid particles and liquid from contaminating components in the vacuum system.

CAUTION: Examine air filter regularly and empty when necessary.

Liquid must not contact any portion of the filter element; remove trapped liquid regularly. Replace the element if it has an overall dirty appearance, or if there is a noticeable increase in the time required to attain full vacuum. (Refer to REPLACEMENT PARTS LIST for filter element kit.)

Filter Service Procedures

- 1) Unscrew the threaded collar (8) from the body (1). Support the body while twisting the collar, to protect the vacuum line fittings from being damaged. Then remove the bowl guard (7) and the bowl (6).

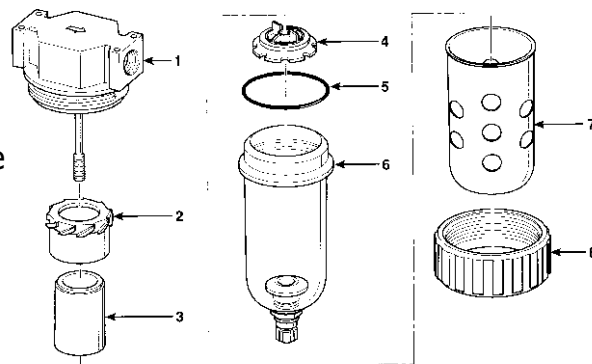

- 2) Determine whether the filter element (3) needs to be replaced (see Conditions Requiring Service preceding). *If so*, proceed to step 3.

If not, remove any liquid or contaminants from the bowl; clean the old bowl seal (5) with mild soap and water; and skip to step 7.

- 3) Unscrew the baffle (4), and remove the element and deflector (2).
- 4) Discard the element and the bowl seal (5).
- 5) Clean all internal parts and the bowl, using mild soap and water only. Do *not* use any other cleaners.
- 6) Install the deflector and a new filter element; then screw the baffle back on (tighten gently, finger-tight) to hold the element in place.
- 7) Lubricate the new or cleaned bowl seal, using a mineral base oil or grease (such as the lubricant furnished in the filter element kit). Do *not* use synthetic oils, such as esters, or silicones.
- 8) Place the bowl seal around the rim of the bowl. Then install the bowl on the body, taking care to avoid contaminating the filter element with lubricant.
- 9) Install the bowl guard and the collar, tightening it only hand-tight (28-32 in-lbs [316-362 N-cm] torque).
- 10) Test the vacuum system to make sure the air filter does not leak (see VACUUM TEST preceding, if applicable).

⚠ WARNING: When the air filter is being used on a *vacuum* system, rather than with pressure, using the twist drain to remove liquid from the bowl is *not* recommended. **Never** disturb the twist drain, as contaminants could lodge in the drain seal and cause a vacuum leak.

VACUUM PUMP MAINTENANCE — THOMAS 2907CDC22/12

⚠ WARNING: Before proceeding with any maintenance, disconnect power source.

If the vacuum pump takes too long to attain full vacuum, it may require maintenance (see OPERATING FEATURES for location of pump). Replace the diaphragms, valve flappers or head gaskets as necessary to obtain acceptable pump performance (see REPLACEMENT PARTS LIST). Perform the following procedures on both heads of the pump.

Replacing a Diaphragm (1)

- 1) Remove the six head screws (14) and remove the head (13).
- 2) Remove the four diaphragm hold-down screws (3) and the diaphragm hold-down plate (2).
- 3) Replace the diaphragm (1) and reverse the above procedure for reassembly.

Replacing an Intake Valve Flapper (6)

- 1) Remove the six head screws (14) and remove the head (13).
- 2) Remove the intake valve flapper screw (4) and the intake valve keeper (5).
- 3) Replace the intake valve flapper (6) and reverse the above procedure for reassembly.

Replacing a Set of Exhaust Valve Flappers (9 & 10) and a Head Gasket (12)

- 1) Remove the six head screws (14) and remove the head (13).
- 2) Turn the head upside-down and remove the five valve plate screws (7).
- 3) Lift out the valve plate (8) to access the exhaust valve flappers (9 & 10) and head gasket (12).²¹
- 4) Remove the exhaust valve flapper screw (11) and replace the exhaust valve flappers.
- 5) Replace the head gasket and reverse the above procedure for reassembly.

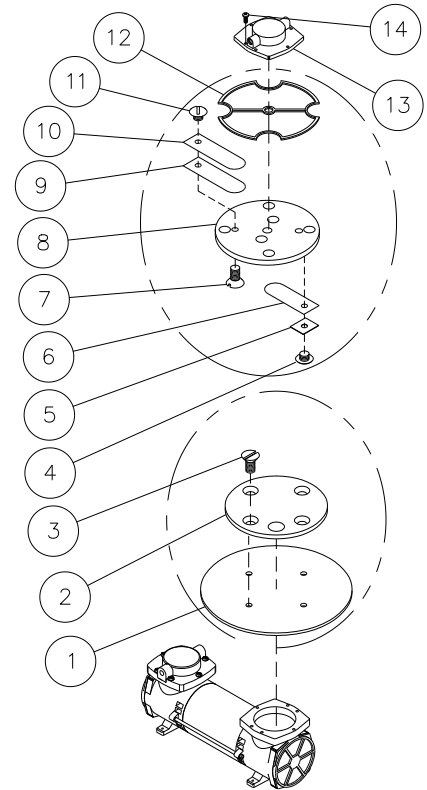

1 DIAPHRAGM	5 INTAKE VALVE KEEPER	10 EXHAUST VALVE FLAPPER (METAL)
2 DIAPHRAGM HOLD-DOWN PLATE	6 INTAKE VALVE FLAPPER (METAL)	11 EXHAUST VALVE FLAPPER SCREW
3 DIAPHRAGM HOLD-DOWN SCREWS	7 VALVE PLATE SCREWS	12 HEAD GASKET
4 INTAKE VALVE FLAPPER SCREW	8 VALVE PLATE	13 HEAD
	9 EXHAUST VALVE FLAPPER (PLASTIC)	14 HEAD SCREWS

²¹ **CAUTION:** Depending on the product, the vacuum system may require the valve plate (8) to be rotated to an orientation different from the one shown. When removing the valve plate, always take note of its orientation in the pump head (13), and install the valve plate the same way during reassembly. In all cases, the valve plate must be oriented so that its intake hole is matched with the head port that connects to the check valve.

VACUUM PUMP MAINTENANCE – DYNAFLO DV1032102

⚠ WARNING: Before proceeding with any maintenance, disconnect power source.

If the vacuum pump takes too long to attain full vacuum, it may require maintenance. Replace the diaphragm or the head assembly (see REPLACEMENT PARTS LIST), as necessary to obtain acceptable pump performance.

CAUTION: Do not over-tighten the head screws, because this may damage the threads in the pump body.

Replacing the Diaphragm

- 1) Remove the four head screws (1) and lock washers (2), and remove the head assembly (3).
- 2) Remove the diaphragm retaining screw (4), diaphragm (5), rubber O-ring (6) and flat washer (7). Be sure to note the diaphragm orientation for reassembly.
- 3) Replace the flat washer, rubber O-ring, diaphragm and diaphragm retaining screw.
- 4) Reverse the steps above for reassembly, as shown.

Replacing the Head Assembly²²

- 1) Remove the hose fittings from the head assembly, and carefully clean the threads. Be sure to note the fitting locations for reassembly.
- 2) Remove the four head screws (1), lock washers (2) and head assembly (3).
- 3) Replace the head assembly, and reverse the steps above for reassembly, as shown.
- 4) Reinstall the hose fittings, using an appropriate thread sealant.

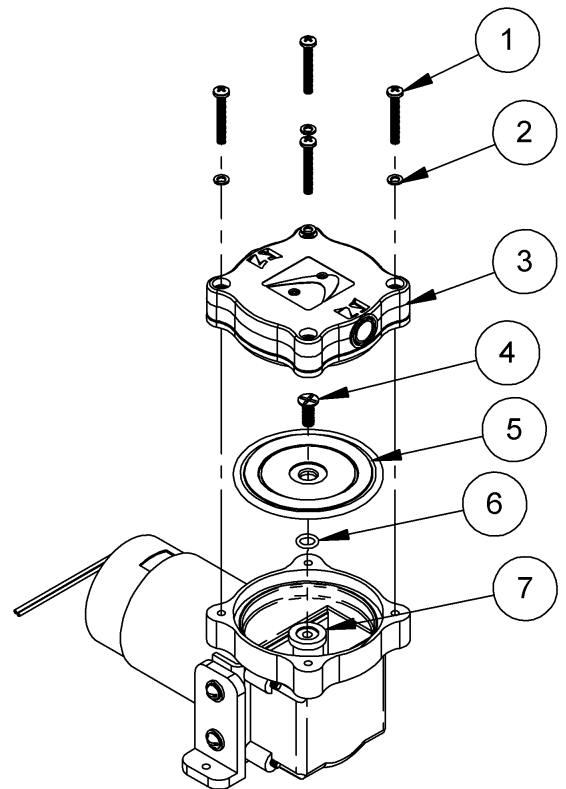

1 HEAD SCREW	5 DIAPHRAGM
2 LOCK WASHER	6 RUBBER O-RING
3 HEAD ASSEMBLY	7 FLAT WASHER
4 DIAPHRAGM RETAINING SCREW	

²² **CAUTION:** Depending on the product, the head assembly (3) may be rotated to an orientation different from the one shown. When removing the head assembly, always take note of its orientation and install it the same way during reassembly. Make sure that the intake and exhaust ports remain in their original positions.

VACUUM SWITCH ADJUSTMENT

Vacuum Switch Function²³

A vacuum switch controls the vacuum pump and the vacuum lift light for a DC lifter (see OPERATING FEATURES for location of vacuum switch). When the lifter's power switch is in the "on" position (), activating the attach function engages the vacuum pump, which evacuates the vacuum pads. After the lifter attains a vacuum level sufficient for lifting the maximum load weight (hereafter, "minimum lifting level"), the vacuum switch automatically turns off the pump and turns on the lift light.²⁴ In order to maintain sufficient vacuum, the vacuum switch automatically turns on the pump and turns off the lift light again before vacuum decreases to a level that is lower than the minimum lifting level.

Conditions Requiring Readjustment

At the factory, the vacuum switch is set to maintain the minimum vacuum level specified for Load Capacity (see SPECIFICATIONS). However, shipping vibrations or shocks, normal wear, or other conditions may adversely affect this adjustment. Periodically verify the switch adjustment by comparing how the vacuum pump and the vacuum lift light function in relation to the vacuum level registered on the vacuum gauge, as follows:

- If the pump *turns off* and the lift light *turns on before* vacuum attains the minimum lifting level, it is likely that the air filter's element is dirty. **Any filter element that obstructs airflow must be replaced** (refer to AIR FILTER MAINTENANCE preceding). Otherwise, the pump would turn off at vacuum levels that are not sufficient to lift the maximum load weight.
- If the pump *turns off* but the lift light *does not turn on after* vacuum attains the minimum lifting level, the light bulb may be burned out. The bulb should be replaced when necessary. Otherwise, the operator might wait unnecessarily for the lift light to turn on, after the lifter has already attained sufficient vacuum to lift the maximum load weight.
- If the pump *does not turn off* and the lift light *does not turn on after* vacuum increases to a level much *higher* than the minimum lifting level, the vacuum switch may be adjusted to maintain a lower vacuum level. Otherwise, the pump would continue to run unnecessarily after the lifter has attained sufficient vacuum to lift the maximum load weight.
- If the pump *does not turn on* and the lift light *does not turn off before* vacuum decreases to a level *lower* than the minimum lifting level, the vacuum switch **must be adjusted to**

²³ Lifters equipped with a Dual Vacuum System have 2 vacuum switches. Directions are the same for these lifters **except that each vacuum switch must be tested and adjusted individually**. When you are evaluating vacuum system functions under Conditions Requiring Readjustment, remember that each vacuum switch corresponds with one vacuum gauge and one vacuum circuit. After you have removed the cover from the control enclosure, you can trace the vacuum lines to determine which components are connected to one another.

²⁴ When using the lifter at high elevations, reduced atmospheric pressure may prevent the vacuum generating system from attaining the vacuum level set at the factory. This causes the pump to run continuously. If the ability to lift the maximum load weight is not required, the operator can adjust the vacuum switch to maintain a lower vacuum level, allowing the pump to cycle normally. However, be advised that **lifting capacity decreases proportionally with decreasing vacuum**, based on the vacuum level specified for the Load Capacity (see SPECIFICATIONS). For example, if a lifter's Load Capacity is rated at 16" Hg [-54 kPa], lifting capacity decreases by 6.25% for each inch of Hg subtracted from (or for each 3.4 kPa added to) the vacuum level. **Always maintain a minimum vacuum level of 10" Hg [-34 kPa]**, regardless of the vacuum level specified for the original Load Capacity. In addition, lifter markings should be adjusted to reflect the revised Load Capacity and the vacuum gauge should be marked to indicate the revised minimum lifting level.

maintain a higher vacuum level.²⁵ Otherwise, the lifter would not maintain sufficient vacuum to lift the maximum load weight.

Adjustment Procedure

⚠ WARNING: Load capacity decreases whenever vacuum switch is adjusted to maintain lower vacuum level.

- 1) Using a 1/4" open-end wrench (as provided), turn the adjustment screw about 1/6th turn at a time (approximately one flat of the screw head).
To maintain a *lower* vacuum level, turn the screw *clockwise* (when viewing vacuum switch from end with electrical connectors).
To maintain a *higher* vacuum level, turn the screw *counter-clockwise* (when viewing vacuum switch from end with electrical connectors).
- 2) Recheck the vacuum switch setting following each 1/6th turn of the adjustment screw. In order to test the adjustment accurately, release the vacuum pads completely before reattaching them to a test surface.

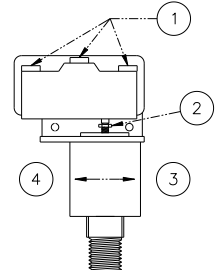

- 1 ELECTRICAL CONNECTORS
- 2 ADJUSTMENT SCREW
- 3 TO MAINTAIN HIGHER VACUUM
- 4 TO MAINTAIN LOWER VACUUM

When the vacuum switch is adjusted correctly, the vacuum pump turns off only *after* vacuum increases to a level higher than the minimum lifting level; and the pump turns on again *before* vacuum decreases to a level lower than the minimum lifting level.

²⁵ In order to observe lifter functions while vacuum is decreasing, it may be necessary to create a controlled leak in the vacuum system (eg, by breaking the seal between one or more vacuum pads and the test surface).

REPLACEMENT PARTS LIST

Stock No.	Description	Qty.
93220	Vacuum Pump – Diaphragm Type – 1 SCFM – 12 V DC (Dynaflor)	2
66197	Dynaflor Pump Head Assembly	2
66197AM	Dynaflor Pump Diaphragm Kit	2
66191	Thomas Pump Gasket	2
66189	Thomas Pump Valve Flapper – Plastic (for exhaust port)	2
66186	Thomas Pump Valve Flapper – Metal (for intake & exhaust ports)	4
66183	Thomas Pump Diaphragm	2
66135	Vacuum Pump – Diaphragm Type – 3 SCFM – 12 V DC (Thomas)	1
65443	Vacuum Hose – 3/8" ID (approx. 6" in length)	*
65440	Vacuum Hose – 1/4" ID (approx. 179" in length)	*
65438	Vacuum Hose – 1/8" ID (approx. 6" in length)	*
65211AM	Check Valve – 1/8 NPT	1
65010	Pad Spring – Coil Type	16
64752	Audio Alarm – 5-15 V DC – Panel Mount (for low vacuum warning buzzer, if applicable)	1
64713AU	Battery Charger – 7 Amp – 240 V AC – Australian Type	1
64712US	Battery Charger – 7 Amp – 100 / 120 V AC	1
64711EU	Battery Charger – 7 Amp – 240 V AC	1
64682	Battery – 1.5 V DC – AA Alkaline (for optional radio transmitter)	4
64667	Battery – 12 V DC – 26 Amp-Hours	1
64590	Battery Gauge	1
64464	Circuit Breaker – 30 A	1
64283	Bulb – 13 V – Bayonet (for vacuum lift light)	1
64271	Strobe Light – 12 V DC – Amber (option)	1
64262	Green Lens (for vacuum lift light)	1
64256AM	Blue Indicator Light – 12 V DC	1
64236	Vacuum Switch – 1/4 NPT	1
64213	Push-Button Switch – Chrome (for "attach", "enable", and "release" buttons)	3
64200	Push-Button Switch (for battery test button)	1
64191	Contact Block (for power switch)	1
58197	Remote Control System Retrofit Kit (optional)	1
58168	Guard for Rotating Union	1
55820	Solenoid Valve Assembly – 12 VDC	1
53132	Hose Fitting – Tee – 5/32" ID	6
53126	Pad Fitting – Tee – 3/64" ID	8
53120	Pad Fitting – Elbow – 3/64" ID	8
49646T	Vacuum Pad – Model G3370 / 11" [28 cm] Diameter – Lipped	16
49150	End Plug – 2-1/2" x 2-1/2" x 1/4" Tubing Size	4
49130	End Plug – 2" x 3" x 1/4" Tubing Size	8
49122	End Plug – 2" x 2" x 1/4" Tubing Size	8
29353	Pad Cover	16
20270	1/4" Open-End Wrench (for adjusting vacuum switch)	1
16132	Filter Element Kit (for 4.4 oz bowl size air filter)	1
16057	Quick Connector – 1/8 FNPS – Male End	12
16056	Quick Connector – 1/8 FNPS – Female End	12
15910	Vacuum Gauge – 1/8 NPT – CBM Type	1
15650	360° Rotating Union – 1/4 NPT	1
15630	Pad Filter Screen – Large	16
13516	Cotterless Hitch Pin – 3/8" x 2-1/2"	8
11124	Hex Nut – 1/2-13 Thread – 85 ksi (for lift bar & rotating pad arms)	40
11120	Hex Nut – 3/8-16 Thread – 85 ksi (for removable sections of pad frame)	16
10900	Shoulder Bolt – Socket Head – 5/16" X 1/2" X 1/4-20 Thread (for mounting pads)	96
10863	Bolt – Hex Head – 1/2-13 Thread x 6-1/2" – Grade 5 (for lift bar)	24
10834	Bolt – Hex Head – 1/2-13 Thread x 1-1/2" – Grade 5 (for rotating pad arms)	16
10822	Bolt – Hex Head – 3/8-16 Thread x 5" – Grade 5 (for removable sections of pad frame)	16

* Vacuum hose is sold by the foot (approx. 30.5 cm).

Service only with identical replacement parts, available at wpg.com or through an authorized WPG dealer.

LIMITED WARRANTY

Powr-Grip products are carefully constructed, thoroughly inspected at various stages of production, and individually tested. They are warranted to be free from defects in workmanship and materials for a period of one year from the date of purchase.

If a problem develops during the warranty period, follow the instructions hereafter to obtain warranty service. If inspection shows that the problem is due to defective workmanship or materials, Powr-Grip will repair the product without charge.

WARRANTY DOES NOT APPLY WHEN:

Modifications have been made to the product after leaving the factory.

Rubber portions have been cut or scratched during use.

Repairs are required due to abnormal wear and tear.

The product has been damaged, misused or neglected.

If a problem is not covered under warranty, Powr-Grip will notify the customer of costs prior to repair. If the customer agrees to pay all repair costs and to receive the repaired product on a C.O.D. basis, Powr-Grip then will proceed with repairs.

TO OBTAIN REPAIRS OR WARRANTY SERVICE

For purchases in *North America*:

Contact the Technical Service Department at Wood's Powr-Grip Co. When factory service is required, ship the complete product—prepaid—along with your name, address and phone number to the street address hereafter.

For purchases in *all other localities*:

Contact your dealer or the Technical Service Department at Wood's Powr-Grip Co. for assistance.

Wood's Powr-Grip Co., Inc.
908 West Main St. / P.O. Box 368
Laurel, MT USA 59044

phone 800-548-7341

phone 406-628-8231

fax 406-628-8354

WIRE LEGEND: CONTROLLED BY WIRING SYMBOLS DRAWING EXCEPT AS NOTED AND BELOW. LINE STYLES AND WIDTHS FOR WIRE UNLESS NOTED OTHERWISE.		FILE DIRECTORY: 713- W07 [W07]	
..... 18AWG	----- 20AWG	TYPE: STANDARD	FILE (SHEET):
N/A	----- N/A	THIS DRAWING IS THE PROPERTY OF WOOD'S POWR-GRIP CO., INC. LAUREL, MONTANA U.S.A. WPG IT IS LOANED WITH THE UNDERSTANDING THAT NEITHER IT NOR ANY INFORMATION CONTAINED THEREIN WILL BE COPIED, PUBLISHED OR TRANSMITTED TO OTHERS WITHOUT EXPRESS WRITTEN PERMISSION.	
PRODUCT MANAGER: SEAN E.	DATE: 03/04/2013	DC2 VACUUM CONTROL SYSTEM N/A STROBE LIGHT WIRING SCHEMATIC, LONG D713-W07 [W07]	
CHECKED: <i>CR</i>	<i>08-22-16</i>	SIZE: A	SCALE: NONE
APPROVED: <i>MM</i>	<i>8-22-16</i>	REVISION: 01.A	ECN NUMBER: 4016
		ECN DATE: 07/06/2016	ECN BY: JAC
			EST. WEIGHT: N/A

NOTES:
1) TERMINAL WITH THE SMALL DOT.

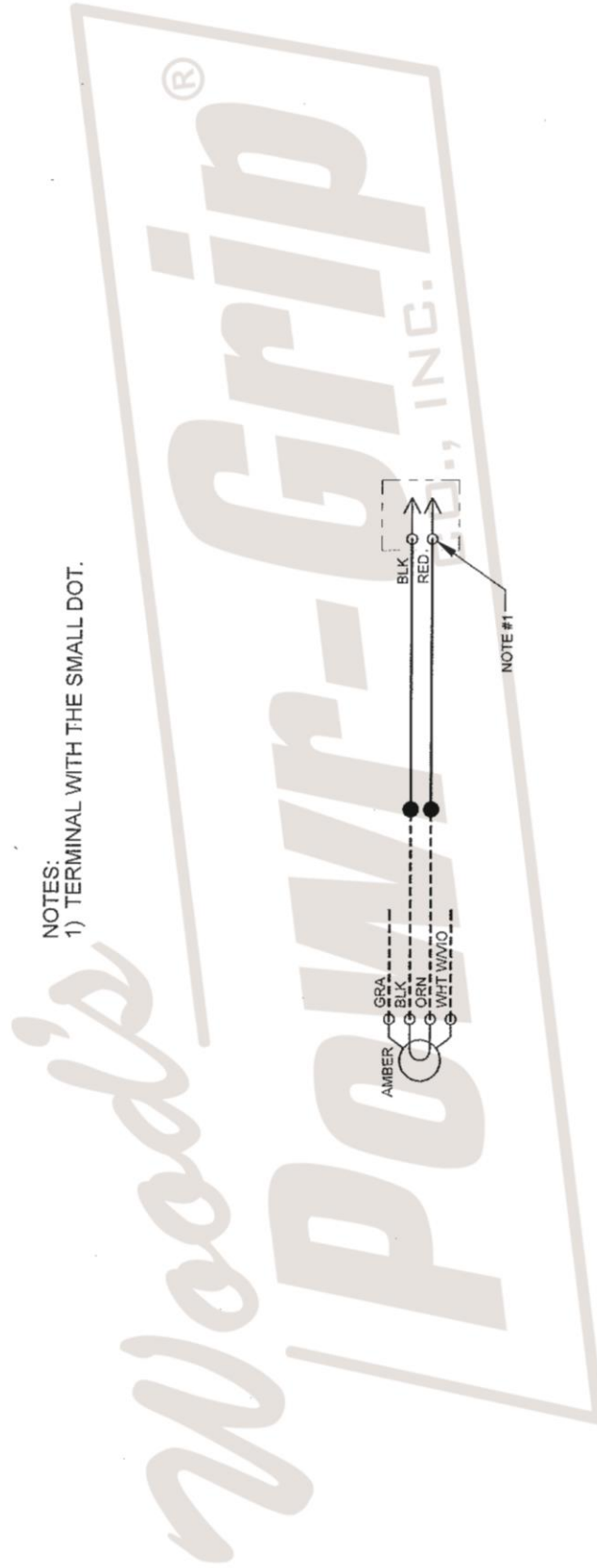

FILE DIRECTORY:
FILE (SHEET):

713-W07 [W07]

TYPE:
STANDARD

THIS DRAWING IS THE PROPERTY OF
WOOD'S POWR-GRIP CO., INC.
IT IS LOANED WITH THE UNDERSTANDING THAT NEITHER IT NOR ANY
INFORMATION CONTAINED THEREIN WILL BE COPIED, PUBLISHED OR
TRANSMITTED TO OTHERS WITHOUT EXPRESS WRITTEN PERMISSION.
LAUREL, MONTANA U.S.A.

WIRE LEGEND: CONTROLLED BY
WIRING SYMBOLS DRAWING
EXCEPT AS NOTED AND BELOW.
LINE STYLES AND WIDTHS FOR
WIRE UNLESS NOTED OTHERWISE.

..... -19AWG
..... -N/A
..... -20AWG
..... -N/A

PRODUCT MANAGER:
SEAN E.

CHECKED: *CL*

APPROVED: *Wm*

DATE: 03/04/2013

08-22-16

8-22-16

REVISION: 01.A

ECN NUMBER: 4016

ECN DATE: 07/06/2016

ECN BY: JAC

EST. WEIGHT: N/A

SIZE: A

SCALE: NONE

DC2 VACUUM CONTROL SYSTEM

N/A

STROBE LIGHT WIRING SCHEMATIC, LONG

D713-W07 [W07]

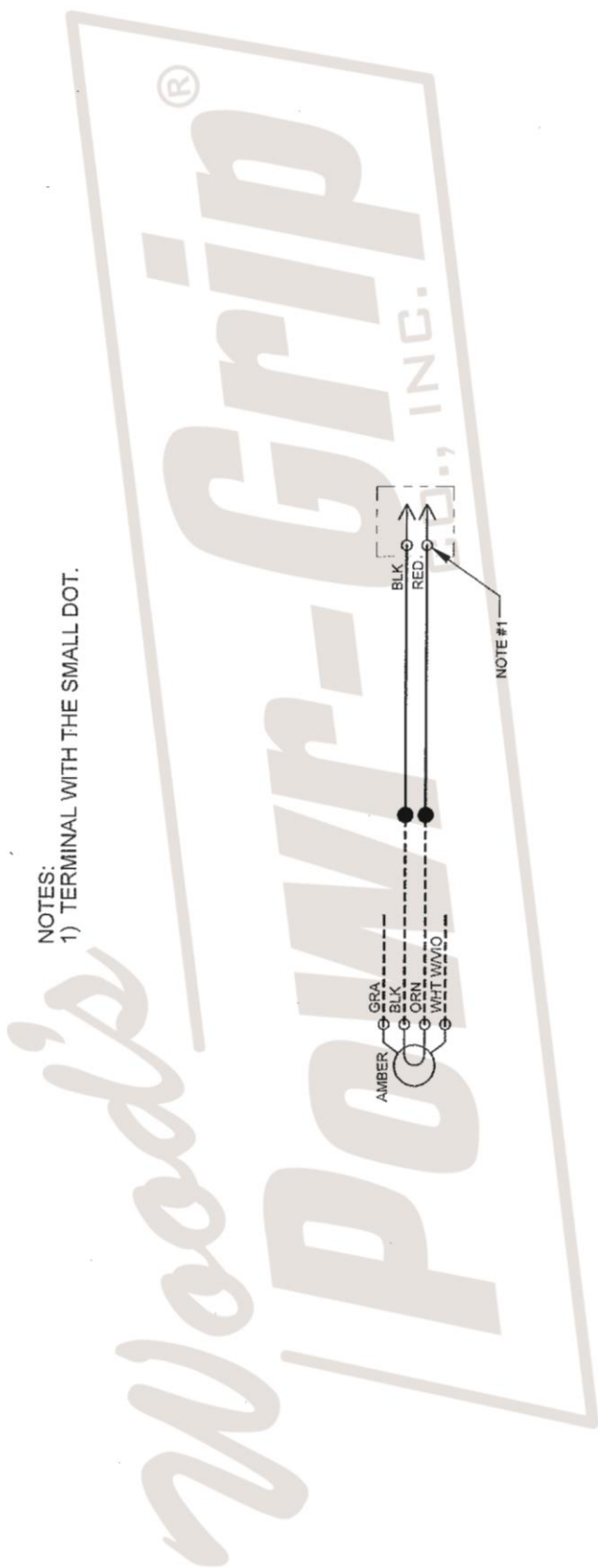

NOTES:
1) TERMINAL WITH THE SMALL DOT.

FILE DIRECTORY:
FILE (SHEET):

TYPE:
STANDARD

714-W01 [W01]

THIS DRAWING IS THE PROPERTY OF **WOOD'S POWR-GRIP CO., INC.** LAUREL, MONTANA U.S.A.
IT IS LOANED WITH THE UNDERSTANDING THAT NEITHER IT NOR ANY INFORMATION CONTAINED THEREIN WILL BE COPIED, PUBLISHED OR TRANSMITTED TO OTHERS WITHOUT EXPRESS WRITTEN PERMISSION.



3 SCFM DC POWER UNIT

N/A

BATTERY CHARGER WIRING DIAGRAM

D714-W01 [W01]

ECN BY: LER

EST. WEIGHT: 0 LBS

ECN DATE: 01/07/2015

ECN NUMBER: 3623

REVISION: 01.A

SIZE: A NONE

WIRE LEGEND: CONTROLLED BY WIRING SYMBOLS DRAWING EXCEPT AS NOTED AND BELOW.

LINE STYLES AND WIDTHS FOR WIRE UNLESS NOTED OTHERWISE.

--- 18 AWG ---
--- 16 AWG ---
----- N/A -----
----- N/A -----

PRODUCT MANAGER: NATHAN G.

DATE: 10/21/2009

CHECKED: *CR*

APPROVED: *Chen*

01-19-15

2-16-15

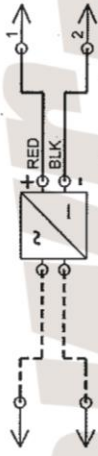
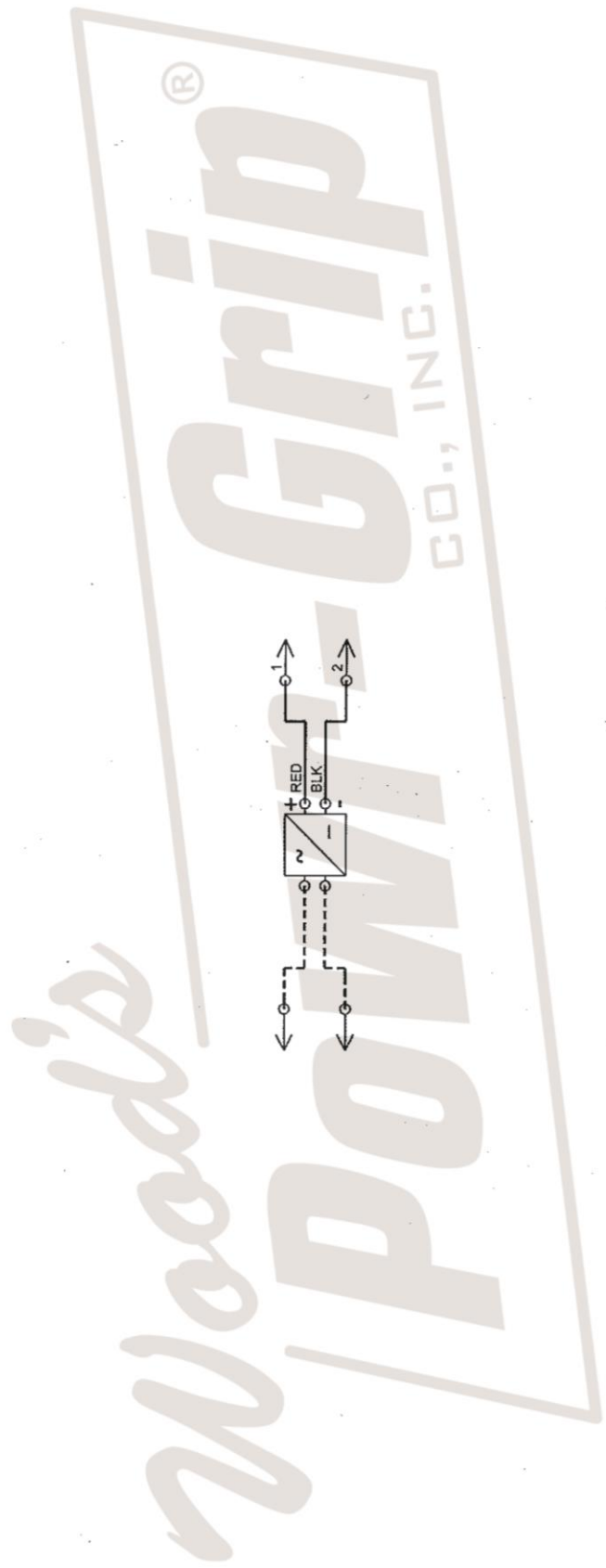

DIRECTORY: \\Rodney\des\gn\Working\STD\714-DCPPI\EN 2993\714A-W01 [A-W01]
 TYPE: **STANDARD**
 FILE (SHEET):
714A-W01 [A-W01]

THIS DRAWING IS THE PROPERTY OF **WOOD'S POWR-GRIP CO., INC.**
 IT IS LOANED WITH THE UNDERSTANDING THAT NEITHER IT NOR ANY
 INFORMATION CONTAINED THEREIN WILL BE COPIED, PUBLISHED OR
 TRANSMITTED TO OTHERS WITHOUT EXPRESS WRITTEN PERMISSION.
 LAUREL, MONTANA U.S.A.

3 SCFM DC POWER UNIT
 GAUGE
 VACUUM ENCLOSURE WIRING SCHEMATIC, SINGLE PUMP
 D714A-W01 [A-W01]

DATE: 10/04/2012 BY: RAS
 REV: 12 ECN NUMBER: 2993
 SCALE: **A NONE**
 SIZE: 11-15-12

DATE: 03/07/1993
 DRAWN: J. ROLFSRUD
 CHECKED: *CR*
 APPROVED: *Omni*

DATE: 11-15-12
 APPROVED: *Omni*

WIRE LEGEND: CONTROLLED BY WIRING SYMBOLS DRAWING EXCEPT AS NOTED AND BELOW.
 LINE STYLES AND WIDTHS FOR WIRE UNLESS NOTED OTHERWISE.
 --- 16AWG --- 14AWG --- 10AWG

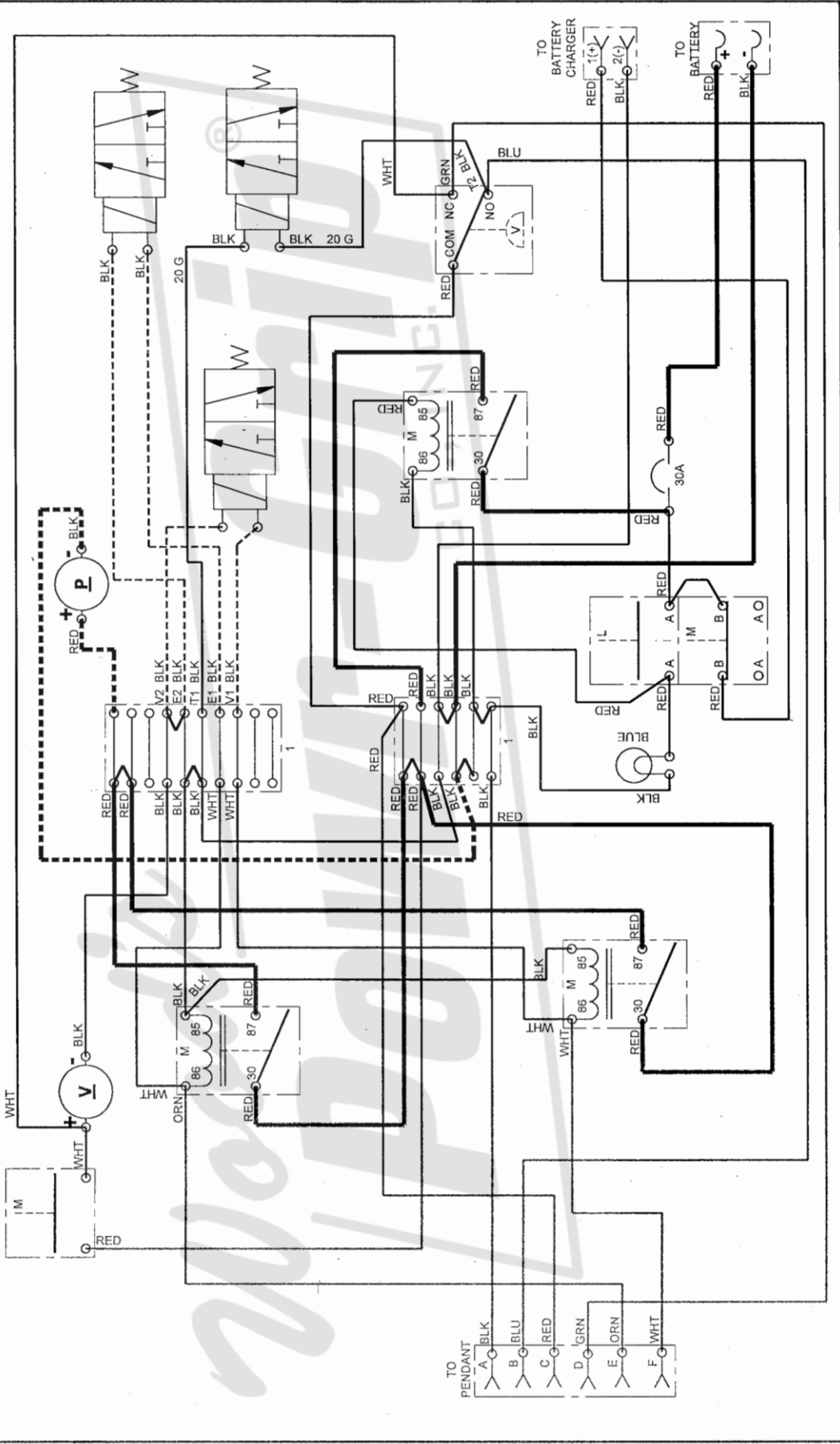

DIRECTORY: \\Rodney\design\Working\STD\714-DCP\IECN 2993
714A-W01 [A-W05]

TYPE: STANDARD
WIRE LEGEND: CONTROLLED BY WIRING SYMBOLS DRAWING EXCEPT AS NOTED AND BELOW.
LINE STYLES AND WIDTHS FOR WIRE UNLESS NOTED OTHERWISE.

THIS DRAWING IS THE PROPERTY OF WOOD'S POWR-GRIP CO., INC. IT IS LOANED WITH THE UNDERSTANDING THAT NEITHER IT NOR ANY INFORMATION CONTAINED THEREIN WILL BE COPIED, PUBLISHED OR TRANSMITTED TO OTHERS WITHOUT EXPRESS WRITTEN PERMISSION.
LAUREL, MONTANA U.S.A.

16AWG - - - - -
14AWG - - - - -
10AWG - - - - -

3 SCFM DC POWER UNIT
GAUGE
VACUUM ENCLOSURE WIRING SCHEMATIC, DUAL PUMP
D714A-W01 [A-W05]

DRAWN: R. SCHNEIDER
DATE: 01/18/2011
CHECKED: CR
APPROVED: CMM

SIZE: SCALE: A NONE
REV: 3
ECN NUMBER: 2993
DATE: 10/04/2012
BY: RAS

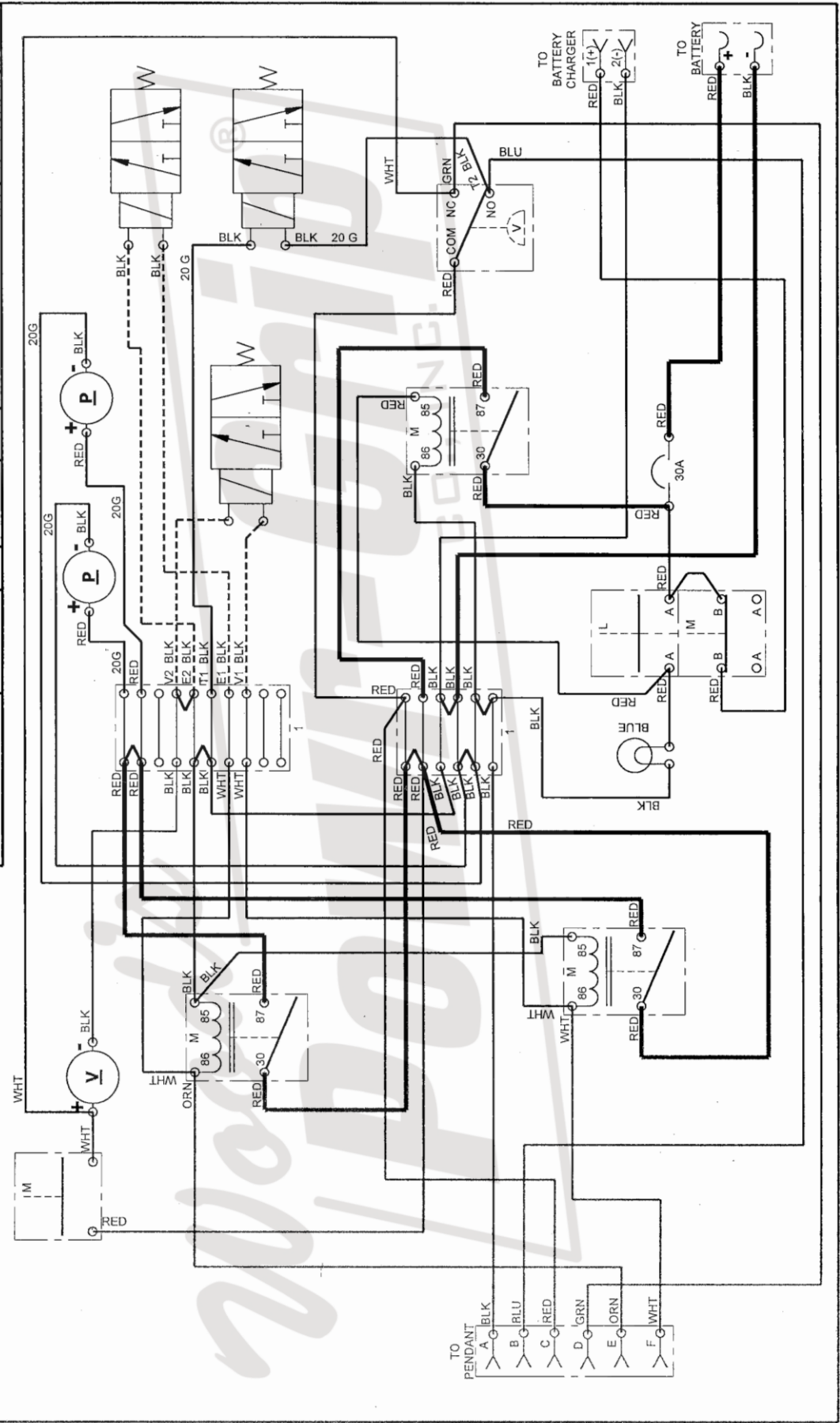

WIRE LEGEND: CONTROLLED BY WIRING SYMBOLS DRAWING EXCEPT AS NOTED AND BELOW. LINE STYLES AND WIDTHS FOR WIRE UNLESS NOTED OTHERWISE. --- 10 AWG --- - - - - - N/A - - - - - - - - - - N/A - - - - - - - - - - N/A - - - - -		TYPE: STANDARD DIRECTORY: 714A-W02 [A-W02] FILE [SHEET]:	
DRAWN: J. ROLF SRUD CHECKED: CR APPROVED: <i>mm</i>		THIS DRAWING IS THE PROPERTY OF WOOD'S POWR-GRIP CO., INC. LAUREL, MONTANA U.S.A. IT IS LOANED WITH THE UNDERSTANDING THAT NEITHER IT NOR ANY INFORMATION CONTAINED THEREIN WILL BE COPIED, PUBLISHED OR TRANSMITTED TO OTHERS WITHOUT EXPRESS WRITTEN PERMISSION.	
DATE: 03/07/1993 05-10-10 5-10-10		3 SCFM DC POWER UNIT GAUGE OPTION BATTERY ENCLOSURE WIRING DIAGRAM D714A-W02 [A-W02]	
SIZE: A		SCALE: NONE	REV.: 6 ECN NUMBER: 2288
DATE: 04/28/2010		BY: LER	

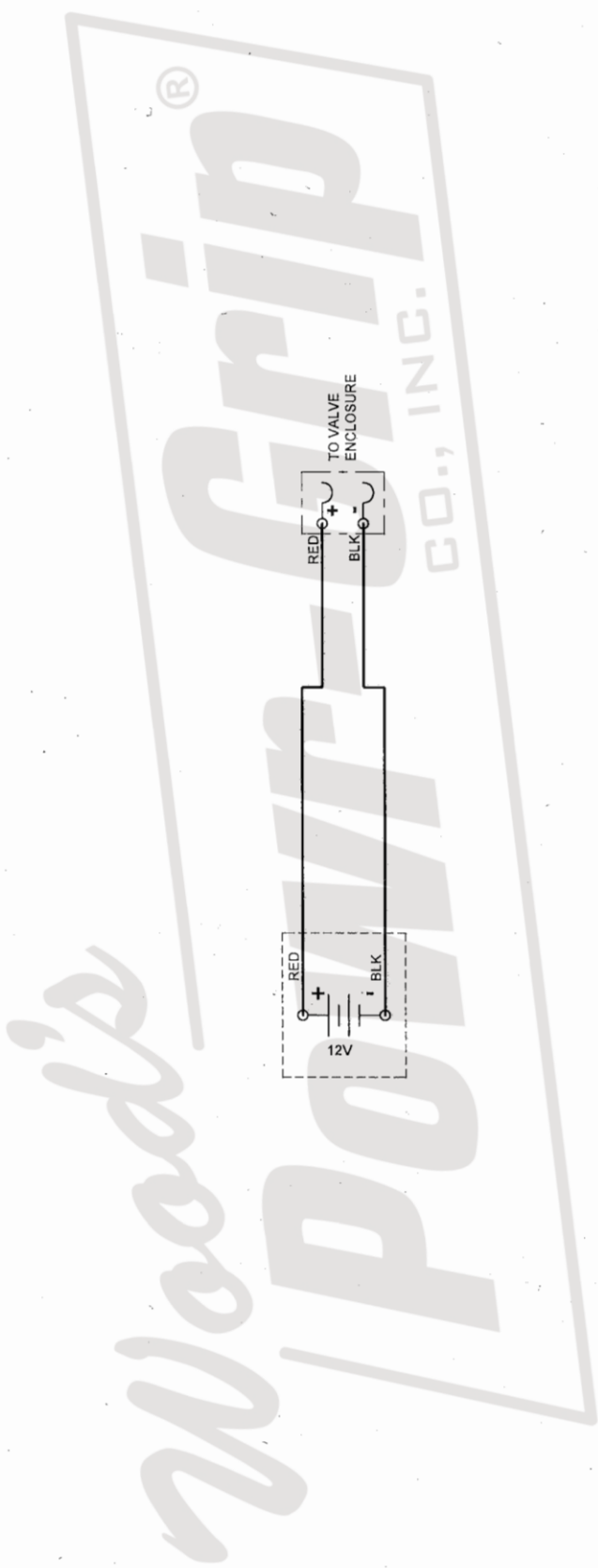

WIRE LEGEND: CONTROLLED BY WIRING SYMBOLS DRAWING EXCEPT AS NOTED AND BELOW. LINE STYLES AND WIDTHS FOR WIRE UNLESS NOTED OTHERWISE. --- N/A --- --- 16AWG --- --- N/A --- --- N/A ---		TYPE: STANDARD	DIRECTORY: FILE [SHEET]: 714A-W03 [A-W03]
DRAWN: L. RENNER DATE: 07/18/2002		THIS DRAWING IS THE PROPERTY OF WOOD'S POWR-GRIP CO., INC. IT IS LOANED WITH THE UNDERSTANDING THAT NEITHER IT NOR ANY INFORMATION CONTAINED THEREIN WILL BE COPIED, PUBLISHED OR TRANSMITTED TO OTHERS WITHOUT EXPRESS WRITTEN PERMISSION. LAUREL, MONTANA U.S.A.	
CHECKED: <i>cl</i>	DATE: 08-20-12	SIZE: A	ECN NUMBER: 2939
APPROVED: <i>Omni</i>	DATE: 08/06/2012	SCALE: NONE	REV: 3
		BY: LER	

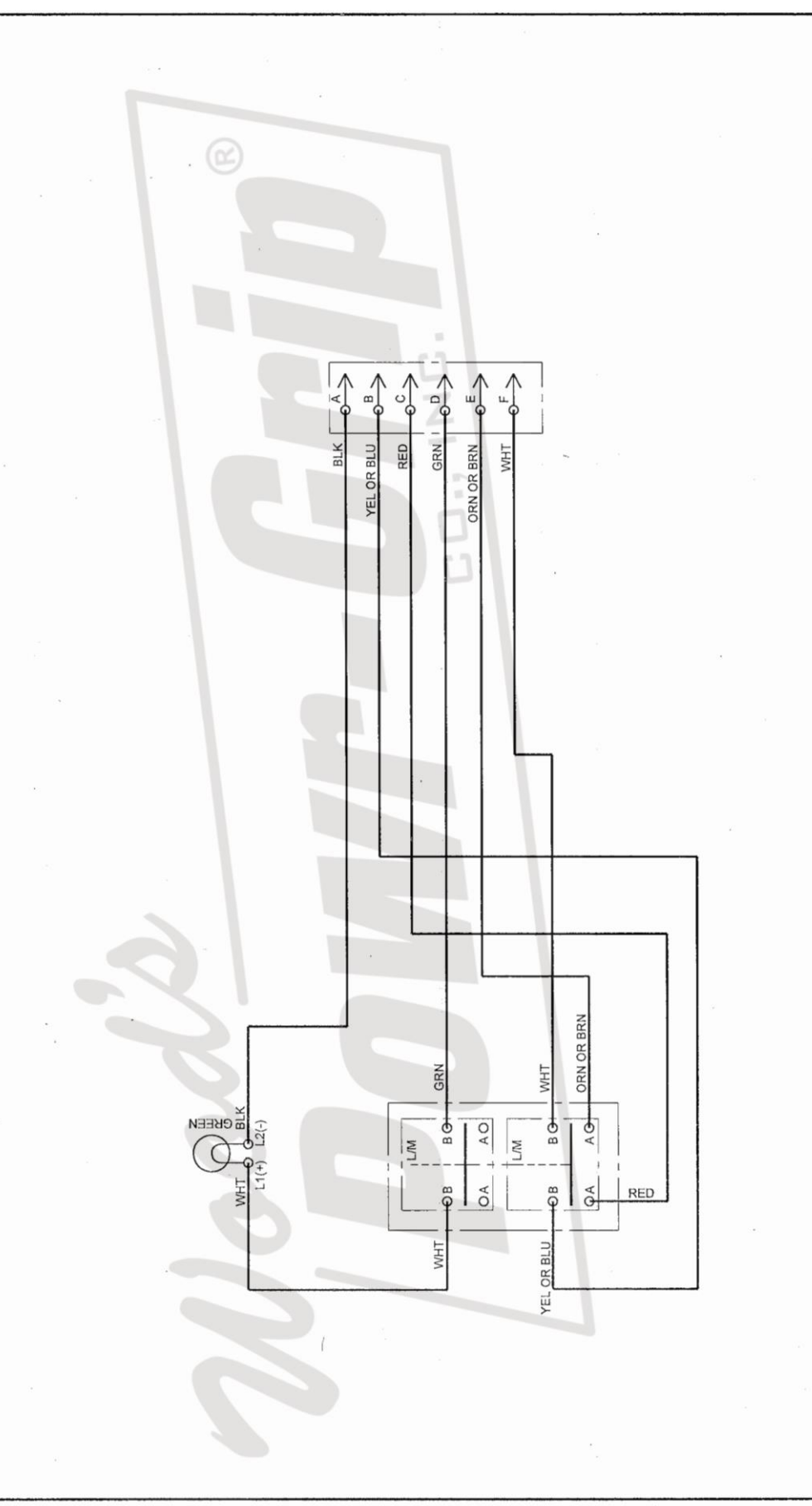

TYPE: STANDARD	FILE DIRECTORY: 714 FILE (SHEET): 714A-W03 [A-W04]
WIRE LEGEND: CONTROLLED BY WIRING SYMBOLS DRAWING EXCEPT AS NOTED AND BELOW. LINE STYLES AND WIDTHS FOR WIRE UNLESS NOTED OTHERWISE. --- N/A --- --- 16AWG --- --- N/A --- --- N/A ---	THIS DRAWING IS THE PROPERTY OF WOOD'S POWR-GRIP CO., INC. LAUREL, MONTANA U.S.A. WFC 3 SCFM DC POWER UNIT GAUGE 2-ACTION PENDANT WIRING SCHEMATIC D714A-W03 [A-W04]
PRODUCT MANAGER: NATHAN G.	REVISION: ECN NUMBER: 3636
CHECKED: <i>CR</i>	ECN BY: CCH
APPROVED: <i>Chen</i>	EST. WEIGHT: 0 LBS
DATE: 09/16/2010	SCALE: A NONE
02-04-15	REVISION: ECN NUMBER: 3636
3-23-15	ECN DATE: 01/19/2015

NOTES:
1) SUBSTITUTE YELLOW WIRE FOR BLUE IF BLUE WIRE IS UNAVAILABLE.
2) SUBSTITUTE BROWN WIRE FOR ORANGE IF ORANGE WIRE IS UNAVAILABLE.

