

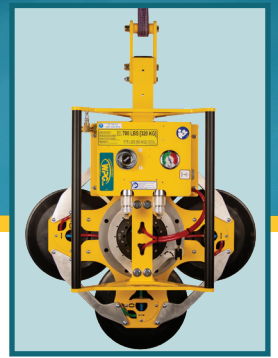

# MANUAL ROTATOR 700

MODEL: MR411LAIR

With continuous 360° rotation, these Powr-Grip® vacuum lifters supply an efficient and economical way to feed vertically oriented processing machinery.



## Updated, Compact Design

Includes extra control handles on the pad frame, as well as an easier-to-use rotation release lever.

## Air Conservation System

Offers noticeably quieter and more efficient use, when compared with other air-powered lifters.

## Pad Shutoffs

Control airflow at specific pads, allowing operators to handle various load shapes and dimensions.

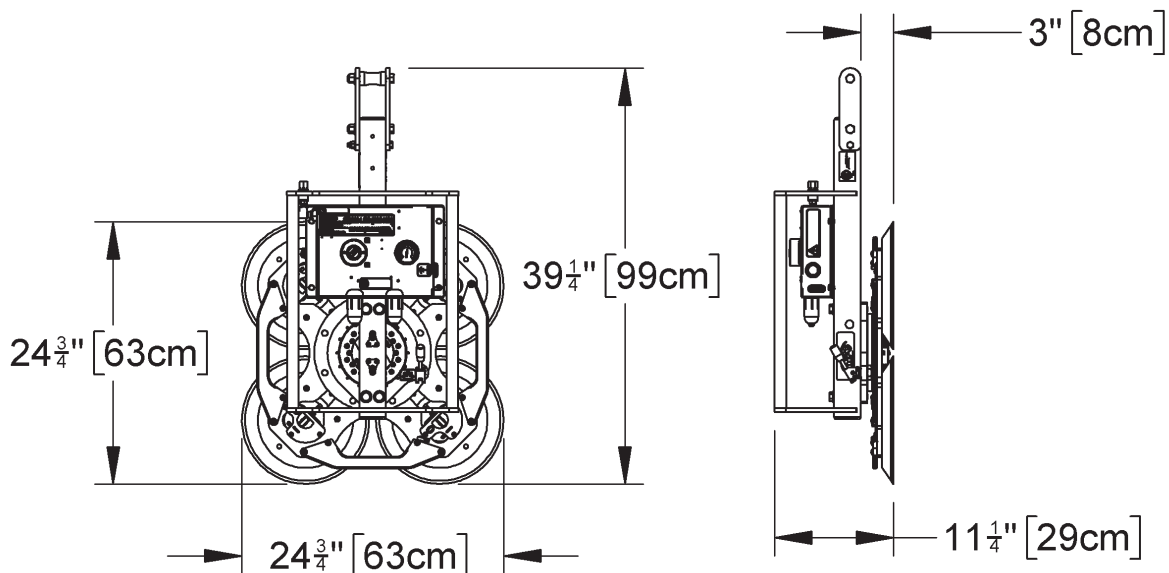

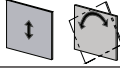
<b>Model</b>	MR411LAIR	
<b>Maximum Load Capacity</b>	700 lbs [320 kg]	
<b>Load Movement</b>	Manual rotation, 360° edgewise, with locking at every 45°	
<b>Standard Operating Power</b>	Compressed Air, 4 SCFM [113 liters/minute] @ 80 psi [550 kPa]	
<b>Attach/Release Time</b>	3 seconds (approximately) / 2 seconds (approximately)	
<b>Standard Pad Spread</b>	24-3/4" x 24-3/4" [63 cm x 63 cm]	
<b>Number/Size of Pads</b>	4 / 11" [28 cm] dia. lipped	
<b>Lifter Weight</b>	80 lbs (37 kg)	

## STANDARD FEATURES

### Adjustable-position lift spool

Provides different lift points to optimize the lifter's hang angle, making repetitive material placement quicker and easier

### Individual Pad Shutoffs

Enable lifter to handle various load sizes and shapes by shutting off airflow from specific vacuum pads

### Vacuum Gauge

Features green and red zones to clearly indicate whether vacuum is sufficient for lifting

### Vacuum Line Filter

Protects the vacuum generating system from contaminants

### Blow-Off Release

Reverses airflow to quickly separate vacuum pads from loads, without after-stick

## AVAILABLE OPTIONS

### Vacuum Loss Warning Buzzer (93780AM)

Uses advanced logic circuitry to monitor vacuum level and sound an alarm only when insufficient vacuum could be hazardous

### Linear Pad Frame (57952)

Provides support and minimizes overhang for long, narrow loads, thanks to a pad spread of 9-1/2" x 52" [24 cm x 132 cm]

### Alternative Vacuum Pads

Adapt lifter to specialized uses, including:

9" [23 cm] diameter pad (VPFS9) for quick attachment to rigid, flat loads

10" [25 cm] diameter, lipped (Model HV11) for handling rough or semiporous, flat loads

(Specifications not as listed above. Please contact us for more information)

### Alternative Pad Compounds

Specially designed for heat resistance, marking resistance, coated surfaces and other purposes

### Alternative Pad Frame Dimensions and Configurations

Enable lifter to handle additional load sizes and shapes

## DESIGN STANDARDS

**ASME B30.20 (BTH-1 Design Category "B", Service Class "0"):** Industry standards established by the American Society of Mechanical Engineers (ASME) and published by the American National Standards Institute (ANSI)



Based on product information at time of publication. Environmental conditions can affect product performance and longevity; consult the product instructions on WPG.com or contact a Technical Sales Representative for more information.

Wood's Powr-Grip products are sold through authorized dealers.