

AIR-POWERED ROTATORS 500 & 800 WITH INTEGRATED HOIST

Designed with an integrated hoist, these Powr-Grip® vacuum lifters use compressed air in production facilities to lift loads and provide effortless 90° rotation.

PRH49AIRS
 500 lbs [225 kg]

PRH611LAIRS
 800 lbs [365 kg]

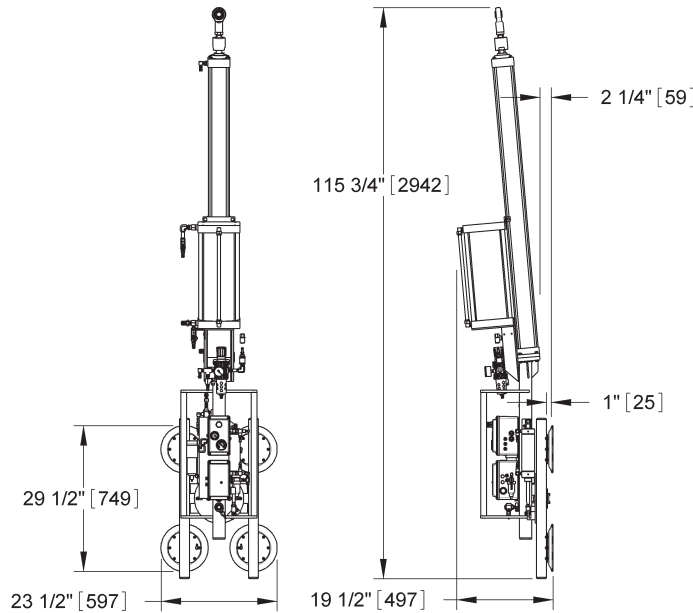
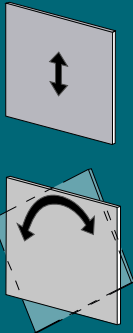

**THE ORIGINAL
 & TRUSTED NAME
 IN VACUUM LIFTING
 EQUIPMENT**

908 West Main - P.O. Box 368
 Laurel, Montana 59044 U.S.A.
 406.628.8231 (phone)
 406.628.8354 (fax)

800.548.7341
www.WPG.com

	PRH49AIRS	PRH611LAIRS
Standard Pad Spread	23½" x 29½" [597 x 749 mm]	26" x 38" [660 x 965 mm]
Number / Size of Pads	4 / 9" [23 cm] diameter	6 / 11" [28 cm] dia. lipped
Load Capacity	500 lbs [225 kg]	800 lbs [365 kg]
Unit Weight	213 lbs [97 kg]	300 lbs [136 kg]
Apply	2 seconds (approximately)	4 seconds (approximately)
Release	1 second (approximately)	3 seconds (approximately)
Standard Operating Power	Compressed air, 6 SCFM [170 liters/minute] @ 80 psi [550 kPa]	
Load Movement	Power rotation, 90° edgewise Powered vertical travel, 48" [122 cm]	
Time for 90° Rotation	4 seconds (approximately)	
Rotation Duty	Continuous	
Standard Features	Vacuum gauge Vacuum reserve tank Vacuum line filter Spring-mounted pads Blow-off for quick release	
Available Options	Vacuum loss warning buzzer (EO3VLW) Individual pad shutoffs (CM1COWB) Linear pad frame (CF8LFO)	
Design Standards (See www.WPG.com for more information.)	ASME B30.20 - 2006 (BTH-1 Design Category "B", Service Class "0")	