

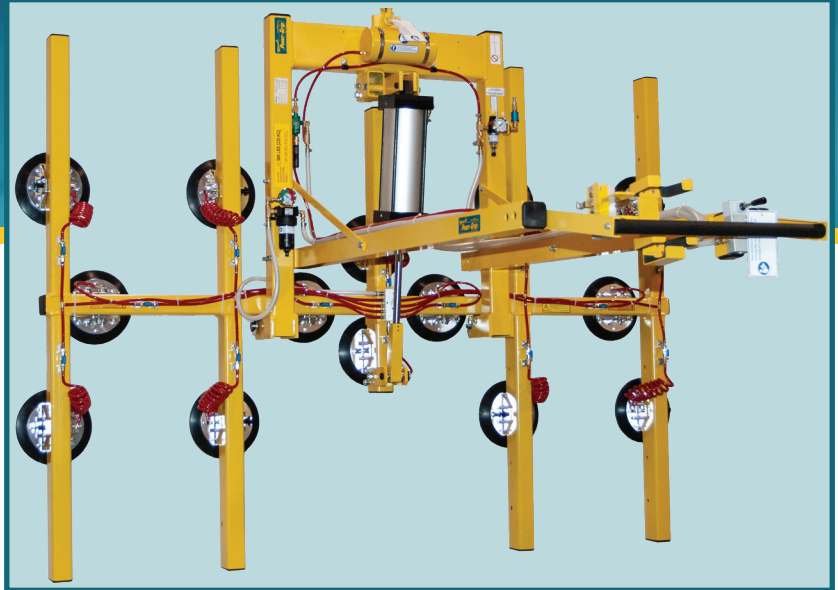

POWER TILTER 1500

MODEL: PT1410TAIR

With its 1500-pound load capacity, this 14-pad model from WPG meets the challenges of lifting and positioning large stone slabs and more.



Compressed-Air Power

Offers greater resistance to moisture, making it a better choice for handling stone.

Powered 90° Tilt Capability

Provides operator with more ease in moving material between the rack and the cutting table.

Individual Pad Shutoffs

Allows attachment of loads that have irregular shapes.

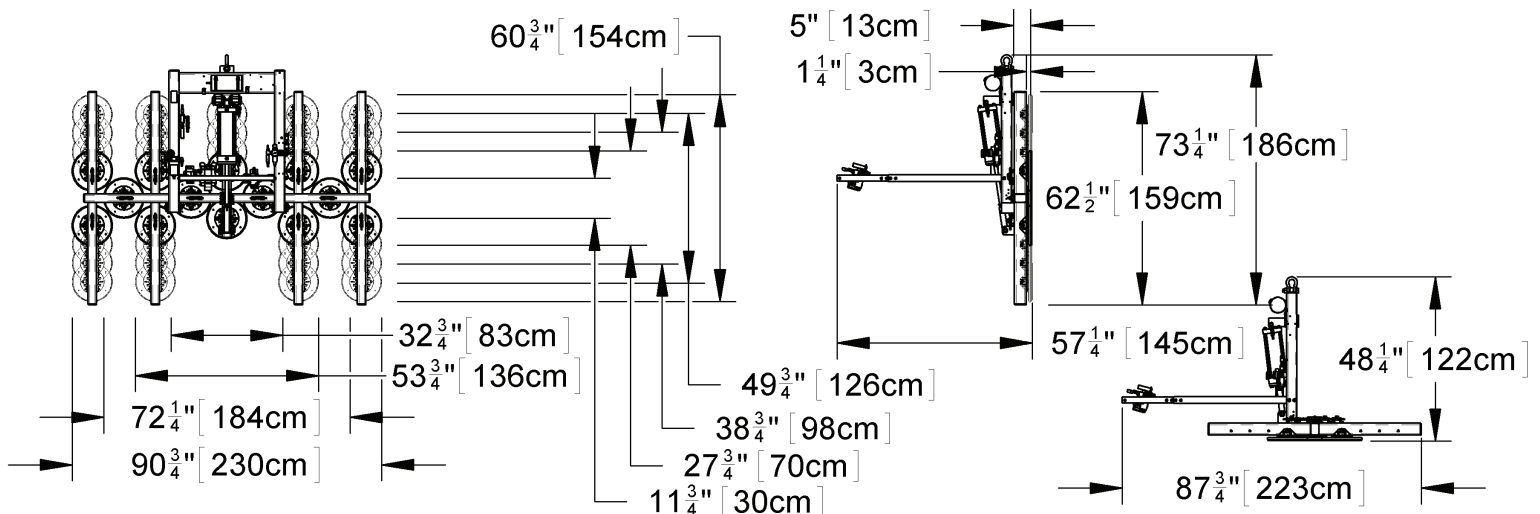

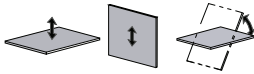
Models	PT1410TAIR
Maximum Load Capacity	1,500 lbs [680 kg]
Standard Pad Spread	Minimum: 11-3/4" x 32-3/4" [30 cm x 83 cm] Maximum: 60-3/4" x 90-3/4" [154 cm x 230 cm]
Number/Size of Pads	14 / 10" [25 cm] diameter vacuum pads with replaceable sealing rings
Load Movement	Power tilt, 90° between upright and flat 
Lifter Weight (for Air-Power System)	545 lbs [248 kg]
Standard Operating Power	Compressed air, 11 SCFM [311 liters/min] @ 80 psi [552 kPa]
Apply/Release Times	10 seconds/ 3 seconds (approximately)
Time for 90° Tilt	8 seconds (approximately)
Tilt Duty	Continuous
Alternative Power Systems (see next page)	AC power system (PT1410TAC) DC power system (PT1410TDC)

STANDARD FEATURES

Individual Pad Shutoffs

Enable lifter to handle various load sizes and shapes by shutting off airflow from specific vacuum pads

Replacable Sealing Rings

Adhere to textured surfaces and resist abrasion from grit and other particles

Spring-Mounted Vacuum Pads

Automatically adjust to match the angle of load surfaces, easing attachment

Vacuum Gauge

Features green and red zones, to clearly indicate whether vacuum level is sufficient for lifting

Vacuum Reserve Tank

Reduces attachment time and extends time for supporting loads during a power outage

Vacuum Line Filters

Prevent contaminants from damaging the vacuum generating system

Movable Pad Mounts

Allow vacuum pads to be moved without tools, adapting the lifter to various load sizes

Control Handle Extensions

Enable the operator to maintain control of the load while remaining safely outside of its tilt path

Two-Action, Blow-Off Release

Uses two separate motions to avoid accidental release, and reverses airflow to quickly release loads without after-stick

AVAILABLE OPTIONS

12-Volt/DC Vacuum Back-Up System (93756BM)

Employs battery-powered auxiliary pump to automatically maintain vacuum during a power outage

Vacuum Loss Warning Buzzer (93780AM)

Uses advanced logic circuitry to monitor vacuum level and sound an alarm only when insufficient vacuum could be hazardous

Alternative Pad Frame Dimensions and Configurations

Enable lifter to handle additional load sizes and shapes

DESIGN STANDARDS

ASME B30.20 (BTH-1 Design Category "B", Service Class "0"): Industry standards established by the American Society of Mechanical Engineers (ASME) and published by the American National Standards Institute (ANSI)

ALTERNATIVE POWER SYSTEMS

AC POWER SYSTEM

Standard Operating Power	120 volts AC, 50/60 hertz, 12 amps (240 volts AC, 50/60 hertz, 6 amps also available)
Vacuum Pump	Wobble Piston, 5 SCFM [142 liters/min] nominal airflow
Apply/ Release	10 seconds/ 6 seconds (approximately)
Time for 90° Tilt	14 seconds (approximately)
Tilt Duty	40 tilts per hour (at maximum load)
Standard Features	<ul style="list-style-type: none"> • Green Lift Light: Provides visual assurance to know when vacuum is sufficient for lifting • Movable Control Pendant: Enables operator to control lifter functions at a safe distance from loads in motion • Twist-Lock Electrical Plug: Provides a secure connection to the AC power source, to prevent accidental disconnection • Blow-Off Release: Reverses airflow to quickly separate vacuum pads from loads, without after-stick
Lifter Weight	610 lbs [277 kg]

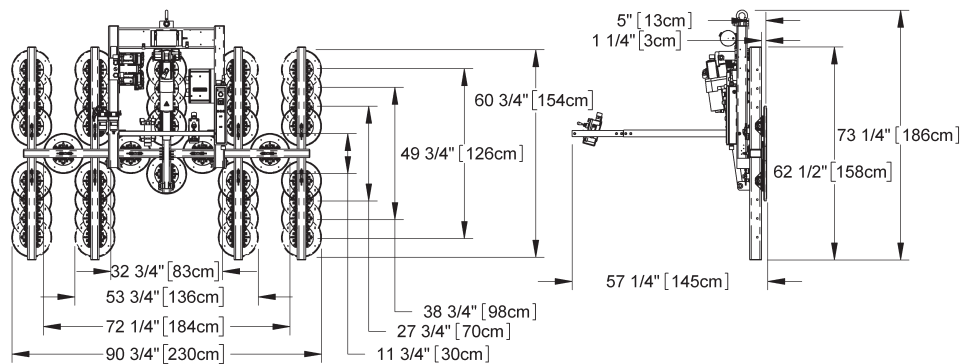

DC POWER SYSTEM

Standard Operating Power	12 volts DC, 33 amps
Vacuum Pump	Diaphragm type, 3 SCFM [85 liters/min] nominal airflow
Apply/ Release	10 seconds/ 6 seconds (approximately)
Time for 90° Tilt	21 seconds (approximately)
Tilt Duty	36 tilts per hour (at maximum load)
Standard Features	<ul style="list-style-type: none"> • Battery and Charger: Provide independent, rechargeable power source for cord-free lifter operation in any location; on-board charger features status indicator and automatic shut-off • Battery Gauge: Shows energy level in real time, to help determine when charging is needed • Green Lift Light: Provides visual assurance to know when vacuum is sufficient for lifting • Movable Control Pendant: Enables operator to control lifter functions at a safe distance from loads in motion • Blow-Off Release: Reverses airflow to quickly separate vacuum pads from loads, without after-stick
Lifter Weight	635 lbs [289 kg]

