

MANUAL ROTATOR/TILTERS PREMIUM EDITION



In addition to three frame configurations, 90° tilt and continuous 360° rotation, the Premium Edition of Powr-Grip's® most popular Manual Rotator/Tilter features a dual vacuum system and power loss warning buzzer for added safety, a high-flow vacuum pump and blow-off for greater productivity, and reduced power consumption for extended time on the jobsite.

MRT411LDC2
 700 lbs [320 kg]

MRT49DC2
 500 lbs [225 kg]

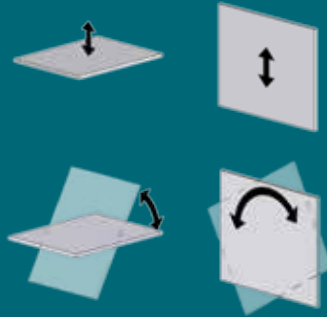

	MRT411LDC2	MRT49DC2
Standard Pad Spread		
Basic Configuration:	28¼" x 32¾" [72 x 83 cm]	25¼" x 30" [64 x 76 cm]
Extended Configuration:	48¼" x 67½" [123 x 172 cm]	45¼" x 64¾" [115 x 164 cm]
Linear Configuration:	78¼" x 15¾" [199 x 40 cm]	75¼" x 12¾" [191 x 32 cm]
Number / Size of Pads	4 / 11" [28 cm] dia. lipped	4 / 9" [23 cm] diameter
Maximum Load Capacity (On smooth, nonporous surfaces. Please contact us for recommendations on other surfaces.)	700 lbs [320 kg]	500 lbs [225 kg]
Unit Weight	125 lbs [57 kg] (Note: does not include weight of any options)	
Standard Operating Power	12 volts DC, 4.5 amps	
Load Movement	Manual rotation, 360° edgewise, with locking at each quarter point. Manual tilt, 90° between upright and flat, with automatic latching in upright position.	
Standard Features	Dual vacuum system High-flow vacuum pump On-board battery and charger Battery energy gauge Low vacuum warning buzzer Power loss warning buzzer Green lift light Vacuum gauges Vacuum line filters Vacuum reserve tanks Spring-mounted vacuum pads Movable pad mounts Pad extension arms Blow-off for quick release	
Available Options	Movable control pendant (EO9RP) Remote control system (EO8RC1) Forklift adapter (LB7FAO1) Adaptable length lift bar (LB6ALO) Long extension arms (CF5LEAO) Individual vacuum pad shutoffs (CM1COWB) Extensions for movable pad mounts (CM6MEVL) Pad frame T-arm assemblies (CF13CEO) MRT4 Shipping case (53006) Alternative vacuum pad materials, including low-marking, temperature resistant, rough surface and coated surface applications	
Design Standards (See www.WPG.com for more information.)	ASME B30.20-2006 (BTH-1 Design Category "B", Service Class "0") CE AS 4991-2004	

**THE ORIGINAL
 & TRUSTED NAME
 IN VACUUM LIFTING
 EQUIPMENT**



908 West Main - P.O. Box 368
 Laurel, Montana 59044 U.S.A.
 406.628.8231 (phone)
 406.628.8354 (fax)

800.548.7341
www.WPG.com



Wood's Powr-Grip products are sold through authorized dealers.

Environmental conditions can affect product performance and longevity; consult the product instructions on www.WPG.com or contact a Technical Sales Representative for more information.
 Based on product information at time of publication.

This lifter's Dual Vacuum System (DVS) features two completely independent vacuum circuits, allowing the vacuum lifter to maintain the vacuum level for one circuit even if an unexpected vacuum loss occurs in the other one. DVS is designed to reduce the risk of falling loads, which could otherwise result from material breakage or accidents that compromise one area of the vacuum system. In addition, DVS features audible and visible alarms that warn the operator whenever the vacuum level is not sufficient for lifting the maximum load weight. Originally designed to comply with CE Standard EN 13155, this system provides additional security in any setting.

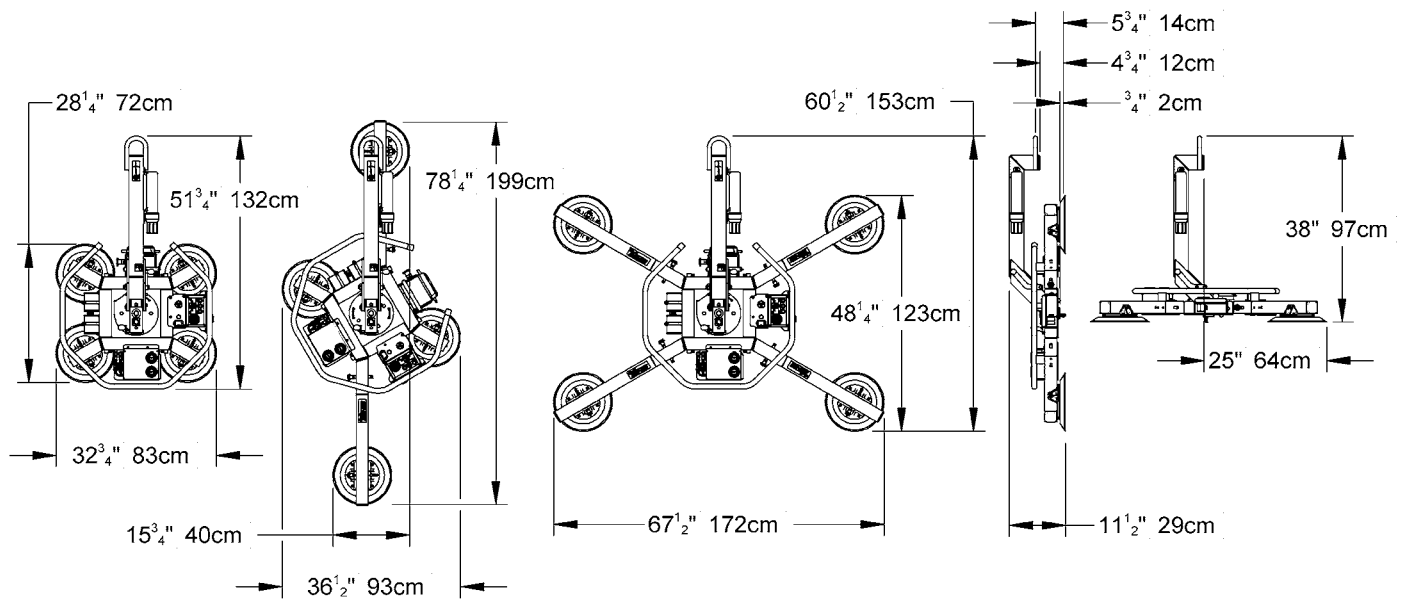

Basic Configuration



Linear Configuration



Extended Configuration



MRT OPTIONS

ADAPTABLE LENGTH LIFT BAR LB6ALO

Designed for applications requiring increased horizontal reach at the hook point or applications involving minimal clearance between the lifter and the hoisting equipment, such as installations under eaves or similar handling situations.



Overhead Clearance Reduction	11-3/4" [298 mm] with Shortened Configurations
Horizontal Reach Increase	7-5/8" [193 mm] with Reversed Bail Configurations
Maximum Load Capacity*	Standard Configuration: 700 lbs [320 kg] Reversed Bail Configuration: 600 lbs [270 kg] Shortened Configuration: 650 lbs [295 kg] Shortened, Reversed Bail Configuration: 500 lbs [225 kg] *Net capacity cannot exceed standard lifter capacity.
Lifter Weight Increase	10 lbs [5 kg]

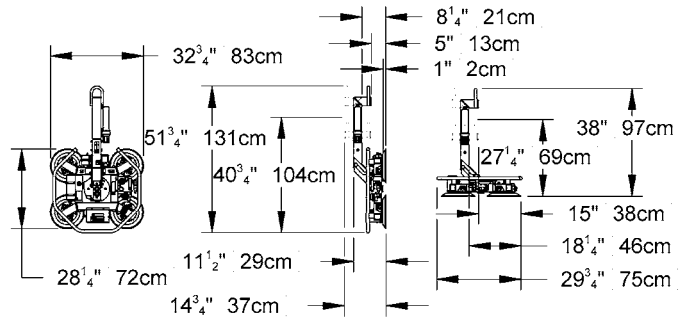

LONG EXTENSION ARMS CF5LEAO

Designed for applications requiring a larger pad spread to reduce overhang on large loads.

Maximum Load Capacity	500 lbs [225 kg] (with long arms installed)
Lifter Weight Increase	10 lbs [5 kg]

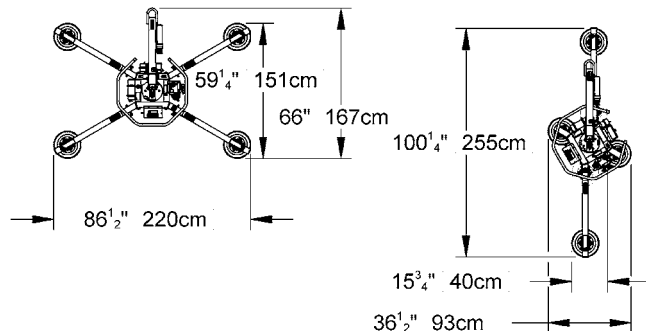

Pad Spread Dimensions provided are for MRT411LDC.

For MRT49DC, subtract 2-3/4" [7 cm]

For MRT4HV11DC, subtract 1-3/4" [5 cm]

FORKLIFT ADAPTER LB7FA01

Designed for applications where a forklift is desired, such as installations under eaves and commercial, indoor applications, where using a crane is not possible.

Compatible Fork Dimensions	1-1/2" to 2-1/4" [38-57 mm] thick and 4" to 6" [102-152 mm] wide
Inside Fork Spread	4" [102 mm]
Maximum Load Capacity	700 lbs [320 kg] when used on MRT411LDC*
Maximum Load Thickness	1" [25 mm] at full capacity
Lifter Weight Increase	130 lbs [59 kg]

*The forklift must have sufficient capacity for the combined weight of the lifter and its maximum load when the load is located 8-3/4" [222 mm] outward from the fork tips or 50-3/4" [1289 mm] outward from the fork stops, whichever places the load at a greater distance from the forklift's front wheels.



Model MRT411LDC vacuum lifter equipped with Forklift Adapter LB7FA01.

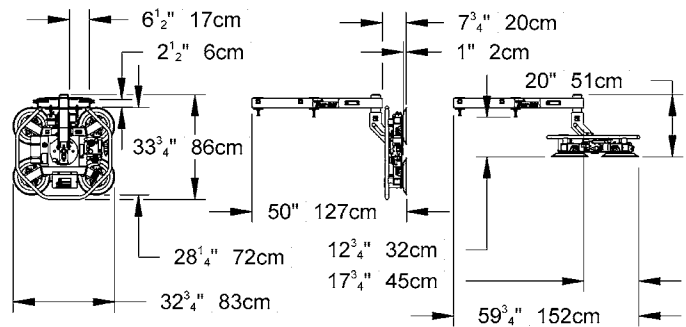

SHIPPING CASE FOR MRT VACUUM LIFTER (VACUUM LIFTER AND CASE SOLD SEPARATELY)

- Designed specifically for shipping and storing Powr-Grip® MRT4 Vacuum Lifters.
- Made from 100% recycled HDPE plastic, features twin sheet, thermo-formed construction, making it very durable, as well as water-resistant.
- Special area to house extension arms for these lifters.
- Internal nylon straps to hold the lifter and extension arms firmly in place, preventing them from rattling around while in transit.
- Exterior rubber straps to hold the case securely closed during shipping.
- Handles molded into the case enable convenient handling.
- Mounting points inside the lid of the case enable the hanging of up to 4 extra vacuum pads.
- Ribbed exterior of case specifically designed for easy stacking of multiple lifters (up to 4).
- Wheels on one end make short distance movement of the lifter manageable by one individual.
- Grooves on the bottom of the case facilitate forklift handling from all four sides.

