

FLEX FLAT LIFTER 1200 WITH SLIDING PAD ARMS & EXTENDED PAD FRAME

MODEL: FLEXRL6HV11

Designed specifically to handle large metal sheets, this flexible vacuum lifter features sliding cross arms and movable vacuum pads to handle a wide variety of material sizes.

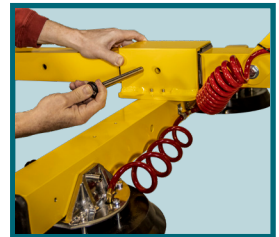
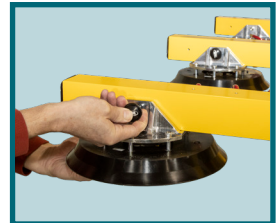
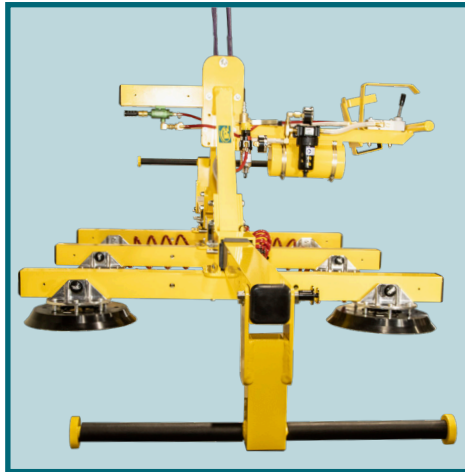
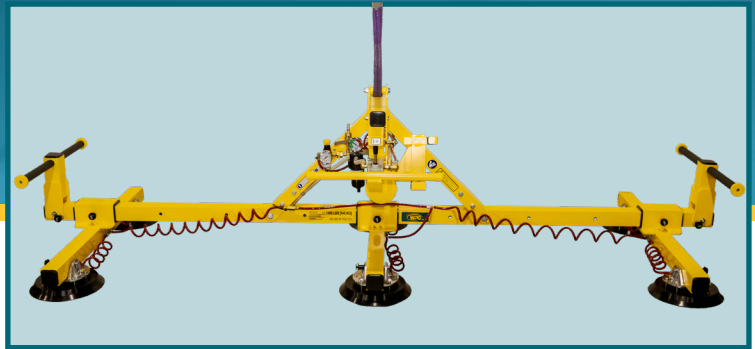

Highly Adaptable Lift Frame

Handle sheet materials as large as 5 by 10 feet (1.5 by 3 meters) or as small as 2 by 5 feet (0.6 by 1.5 meters). Tool-free adjustment makes it simple!

Wide Array of Available Features

Customize your lifter to your specific job requirements! Choose from a broad selection of options, including specialized vacuum pads, pad mounts and pad compounds.

Choice of Power Systems

Whether you need AC or compressed air power to integrate with existing facilities or DC power for cord-free operation, we have a power system to work for you!

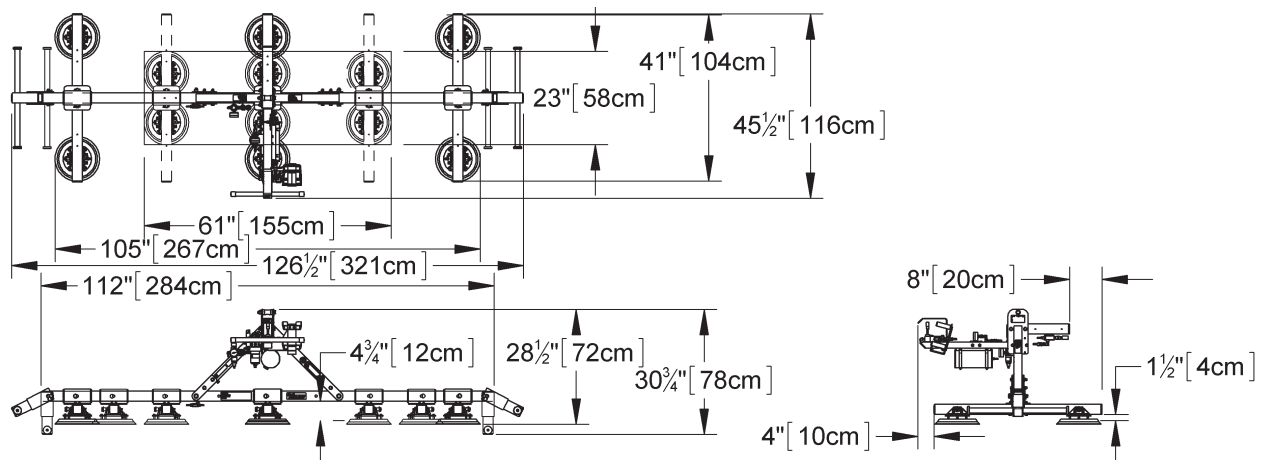

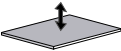
Models	FLEXRL6HV11
Maximum Load Capacity	1,200 lbs [545 kg]
Load Movement	Flat to flat 
Power Systems	See below
Standard Variable Pad Spread	Min: 23" x 61" [58 cm x 155 cm] Max: 41" x 105" [104 cm x 267 cm]
Number/Size of Pads	6 / 10" [25 cm] dia. lipped
Lifter Weight	145 lbs [66 kg] with Air power system (approximately) 185 lbs [84 kg] with AC power system (approximately) 205 lbs [93 kg] with DC power system (approximately)

Air (venturi) power system (FLEXRL6HV11AIR)

Standard Operating Power	Compressed Air, 5 SCFM [142 liters/min] @ 80-150 psi [550-1035 kPa]
Vacuum Pump	Single-stage venturi type, 3 SCFM [85 liters/min] nominal airflow
Apply / Release Times	4 seconds (approx.) / 2 seconds (approx.)

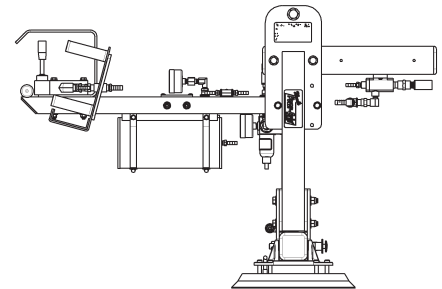

OPTIONAL HIGH-FLOW POWER SYSTEM

Operating Power	Compressed Air, 8 SCFM [227 liters/min] @ 80-150 psi [550-1035 kPa]
Vacuum Pump	Single-stage venturi type, 4 SCFM [113 liters/min] nominal airflow
Apply / Release Times	2 seconds (approx.) / 2 seconds (approx.)

AC power system (FLEXRL6HV11AC)

Standard Operating Power	120 volts AC, 50/60 hertz, 6 amps (240 volts AC, 50/60 hertz, 3 amps also available)
Vacuum Pump	Rotary vane type, 4 SCFM [113 liters/min] nominal airflow
Apply / Release Times	2 seconds (approx.) / 4 seconds (approx.)

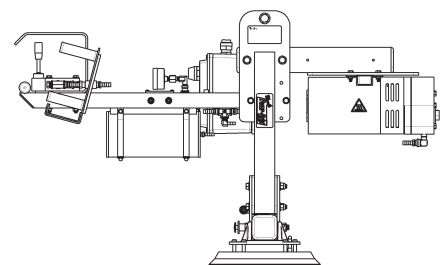

DC power system (FLEXRL6HV11DCS)

Standard Operating Power	12 volts DC, 26 amps
Vacuum Pump	Diaphragm type, 3 SCFM [85 liters/min] nominal airflow
Apply / Release Times	4 seconds (approx.) / 4 seconds (approx.)

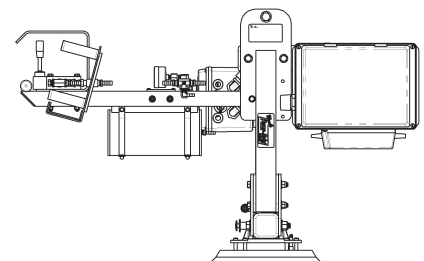

STANDARD FEATURES

Sliding Pad Arms

Allow cross members to slide along the lifter's main beam to match load dimensions

Movable Pad Mounts

Allow vacuum pads to be moved without tools, adapting the lifter to various load sizes

Parking Stands/Control Handles

Allow precise orientation of loads in motion and protect vacuum pads from distortion or damage when lifter is not in use

Vacuum Gauge

Features green and red zones to clearly indicate whether vacuum level is sufficient for lifting

Vacuum Reserve Tank

Reduces attachment time and extends time for supporting loads during a power outage (AC and air-powered lifters);
Increases battery run-time by reducing pump cycles needed to maintain vacuum (DC lifters)

Vacuum Line Filter

Protects the vacuum generating system from contaminants

Spring-Mounted Vacuum Pads

Automatically adjust to match the angle of load surfaces, easing attachment

Blow-Off Release

Reverses airflow to quickly separate vacuum pads from loads, without after-stick

Green Lift Light (FLEXRL6HV11AC)

Provides visual assurance to know when vacuum is sufficient for lifting

Twist-Lock Electrical Plug (FLEXRL6HV11AC)

Provides a secure connection to the AC power source, to prevent accidental disconnection

Battery and Charger (FLEXRL6HV11DCS)

Provide independent, rechargeable power source for cord-free lifter operation in any location; on-board charger features status indicator and automatic shut-off

Battery Gauge (FLEXRL6HV11DCS)

Shows energy level in real time, to help determine when charging is needed

Low Vacuum Warning Light (FLEXR6HV11DCS)

Uses red light to warn operator when vacuum is not sufficient for lifting

AVAILABLE OPTIONS

Vacuum Loss Warning Buzzer (93780AM)

Uses advanced logic circuitry to monitor vacuum level and sound an alarm only when insufficient vacuum could be hazardous

12-Volt/DC Vacuum Back-Up System (93756BM)

Employs battery-powered auxiliary pump to automatically maintain vacuum during a power outage

Individual Pad Shutoffs (93011)

Enable lifter to handle various load sizes and shapes by shutting off airflow from specific vacuum pads

Sliding (Adjustable) Pad Mounts

Accommodate various load sizes by sliding to different locations on the pad frame. "Adjustable" mounts include infinitely variable positioning

Spring-Shaft Pad Mounts (93116)

Employ a spring-loaded suspension to reduce shocks and stress on sheet metal and other loads that tend to flex

Sliding (Adjustable) Spring-Shaft Pad Mounts

Combine the advantages of Sliding (Adjustable) Pad Mounts and Spring-Shaft Pad Mounts

Adjustable Spacers for Movable Pad Mounts (93101 & 93101AM)

Enable lifters to handle windows with mullions or other loads with surface obstructions

AVAILABLE OPTIONS (continued)

Alternative Vacuum Pads

Adapt lifter to specialized uses, including:

10" [25 cm] diameter, concave pad (G0750) for handling curved loads

11" [28 cm] diameter, lipped pad (G3370) for handling rigid, flat loads

(Specifications not as listed above. Please contact us for more information)

Alternative Pad Frame Dimensions and Configurations

Enable lifter to handle additional load sizes and shapes

Alternative Pad Compounds

Specially designed for heat resistance, marking resistance, oily surfaces and other purposes

DESIGN STANDARDS

ASME B30.20 (BTH-1 Design Category "B", Service Class "0"): Industry standards established by the American Society of Mechanical Engineers (ASME) and published by the American National Standards Institute (ANSI)

Based on product information at time of publication.

Environmental conditions can affect product performance and longevity; consult the product instructions on WPG.com or contact a Technical Sales Representative for more information.

