

KEEP FOR FUTURE REFERENCE



*P.O. Box 368 – 908 West Main
Laurel, MT USA 59044
phone 800-548-7341
phone 406-628-8231
fax 406-628-8354*

INSTRUCTIONS

International Version

STOCK NUMBER: 95725

LONG EXTENSION ARMS



***READ ALL INSTRUCTIONS AND WARNINGS
BEFORE USING THIS PRODUCT***



DESIGNED FOR THE MATERIALS HANDLING PROFESSIONAL

SPECIFICATIONS

Stock Number:	95725		
Description:	Long Extension Arms provide a larger Pad Spread to reduce overhang on loads.		
Weight Increase:	10 lbs [5 kg] when Long Extension Arms are installed. Note: Make sure to add the weight of all options to the Lifter Weight when you are selecting appropriate hoisting equipment (see ASSEMBLY in lifter's instruction manual).		
Lifter Model:	MRT411LDCO	MRTALP611LDCO	MRTA811LDC/ACO
Adjusted Max Pad Spread:¹	(to outer edges)		
Rectangular Configuration:	59¼" x 86½" [1506 x 2200 mm]	63¾" x 111½" [1620 x 2833 mm]	80¼" x 126½" [2038 x 3212 mm]
Linear Configuration:	15¾" x 100¼" [398 x 2547 mm]	17" x 124" [430 x 3152 mm]	13¾" x 145¼" [352 x 3688 mm]
Adjusted Max Load Capacity: (when any pad is installed in outermost position on Long Extension Arm)	500 lbs [225 kg]	750 lbs [340 kg]	1000 lbs [455 kg]

WARNINGS



Powr-Grip is pleased to offer the most reliable materials handling products available. Despite the high degree of security provided by the Long Extension Arms, certain precautions must be observed to protect the user and others.



Always wear personal protective equipment that is appropriate for the material being handled. Follow trade association guidelines.

Always use the Long Extension Arms under conditions approved for the design of the vacuum lifter (see lifter's instruction manual).

Never use Long Extension Arms that are damaged, malfunctioning, or missing parts.

Never remove or obscure warning labels on the Long Extension Arms.

Never use Long Extension Arms if the Load Capacity or any warning appears to be missing or obscured.

Never exceed the Load Capacity (see SPECIFICATIONS and OPERATION) or attempt to lift loads the lifter is not designed for (see lifter's instruction manual).

Always remember that modifications to Long Extension Arms may compromise your safety. Wood's Powr-Grip cannot be responsible for products that have been modified by the customer. For consultation, contact Wood's Powr-Grip.

¹ Pad Spreads are shown for lifters equipped with 11" [28 cm], lipped vacuum pads (model G3370). For 10" [25 cm], lipped pads (model HV11), subtract 1¾" [48 mm] from each dimension listed. For 9" [23 cm] pads (model VPFS9), subtract 2¾" [73 mm] from each dimension listed.

ASSEMBLY

Assemble the vacuum lifter as directed in the ASSEMBLY section of the lifter's instruction manual. However, substitute Long Extension Arms wherever extension arms are required. Arrange the pad frame to minimize load overhang and to provide optimal support of the load while lifting.

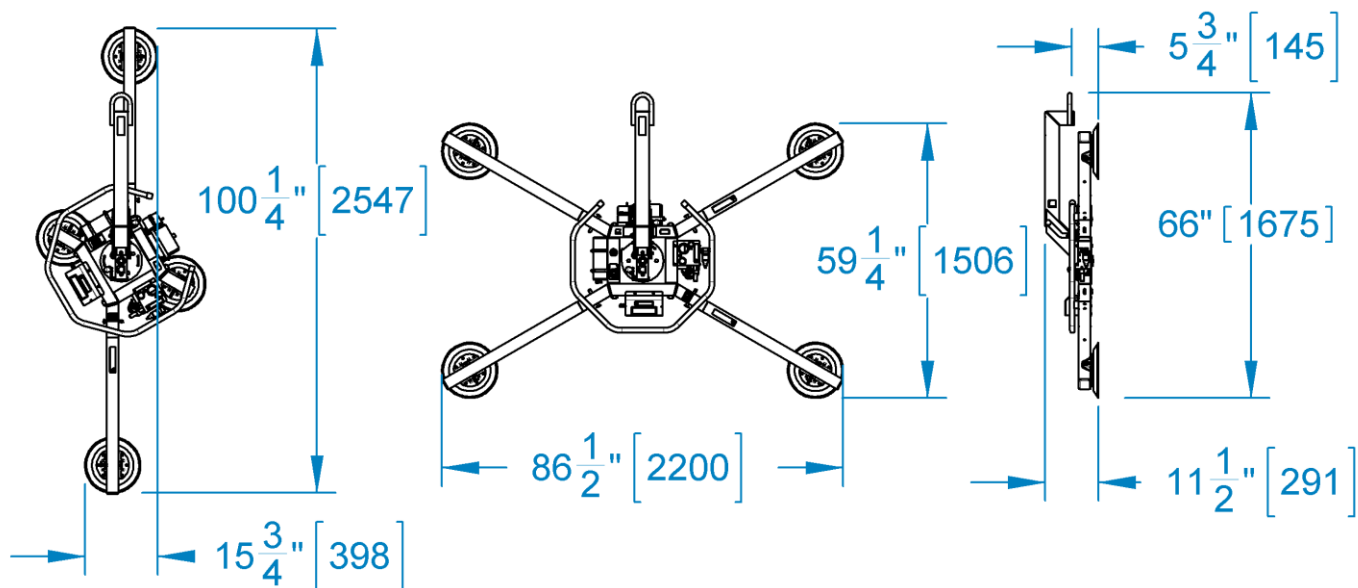

Standard MRT411LDC shown with Long Extension Arms option.

Always assemble the pad frame in a symmetrical arrangement, to keep the lifter balanced.

⚠ WARNING: Make sure vacuum hoses are coiled or routed to avoid damage during lifter operation.

Make sure all vacuum hoses are secure and routed to avoid being punctured, pinched, kinked, entangled, abraded or otherwise damaged while the lifter is in operation.

OPERATION

Consult the vacuum lifter's instruction manual to determine all safety precautions, inspections, tests and other preparations which must be completed prior to using the lifter.

⚠ WARNING: Using Long Extension Arms may reduce lifter's Load Capacity.

Maximum Load Capacity decreases whenever any vacuum pad is located in the outermost position on any of the Long Extension Arms. When evaluating the intended use as required in the lifter's instruction manual, **be sure to consider the Adjusted Maximum Load Capacity and Adjusted Pad Spread listed in the SPECIFICATIONS above (not the ones listed in the lifter's instruction manual).**

Otherwise, operate the vacuum lifter as directed in the lifter's instruction manual.

MAINTENANCE

When performing inspections and tests as directed in the MAINTENANCE section of the lifter's instruction manual, be sure to include all parts of the Long Extension Arms whenever applicable.

REPLACEMENT PARTS LIST

Stock No.	Description	Qty.
49150	End Plug - 2 1/2" x 2 1/2" x 1/4" [63.5 mm x 63.5 mm x 6.4 mm] Tubing Size	4
13532	Cotterless Hitch Pin - 1/2" x 4" [13 mm x 102 mm]	8

***SERVICE ONLY WITH IDENTICAL REPLACEMENT PARTS
SUPPLIED BY OR APPROVED BY WOOD'S POWR-GRIP CO., INC.***

LIMITED WARRANTY

Powr-Grip products are carefully constructed, thoroughly inspected at various stages of production, and individually tested. They are warranted to be free from defects in workmanship and materials for a period of one year from the date of purchase.

If a problem develops during the warranty period, follow the instructions hereafter to obtain warranty service. If inspection shows that the problem is due to defective workmanship or materials, Powr-Grip will repair the product without charge.

WARRANTY DOES NOT APPLY WHEN:

Modifications have been made to the product after leaving the factory.

Rubber portions have been cut or scratched during use.

Repairs are required due to abnormal wear and tear.

The product has been damaged, misused, or neglected.

If a problem is not covered under warranty, Powr-Grip will notify the customer of costs prior to repair. If the customer agrees to pay all repair costs and to receive the repaired product on a C.O.D. basis, Powr-Grip then will proceed with repairs.

TO OBTAIN REPAIRS OR WARRANTY SERVICE

For purchases in *North America*:

Contact the Technical Service Department at Wood's Powr-Grip Co. When factory service is required, ship the complete product--prepaid--along with your name, address and phone number to the street address hereafter.

For purchases in *all other localities*:

Contact your dealer or the Technical Service Department at Wood's Powr-Grip Co. for assistance.

Wood's Powr-Grip Co., Inc.
908 West Main St. / P.O. Box 368
Laurel, MT USA 59044

phone 800-548-7341

phone 406-628-8231

fax 406-628-83