

KEEP FOR FUTURE REFERENCE

INSTALLATION INSTRUCTIONS



908 W. Main • P.O. Box 368

Laurel, MT USA 59044

(1) 800-548-7341

(1) 406-628-8231

www.wpg.com

 **INTENDED FOR USE BY QUALIFIED
SERVICE PERSONNEL • READ AND
UNDERSTAND BEFORE INSTALLING**

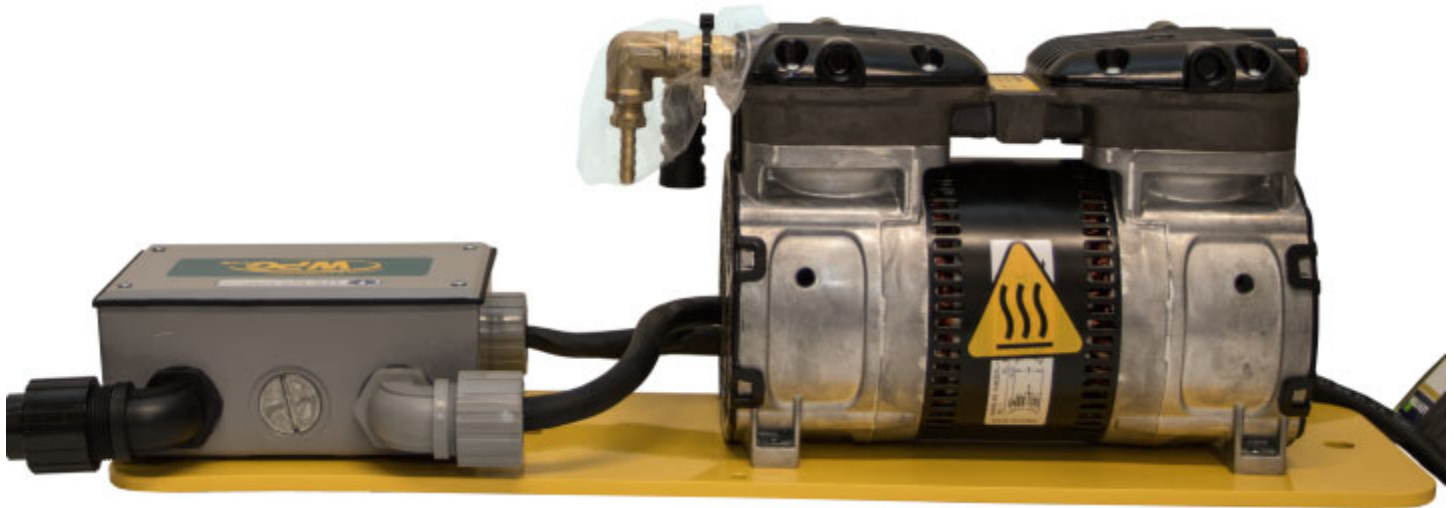

WOBBLE PISTON PUMP CONVERSION KIT

(for MT Series Stone Lifters)



Stock numbers: 93244, 93244AM

Original Instructions © Wood's Powr-Grip Co., Inc.

TABLE OF CONTENTS

SPECIFICATIONS	2
INSTALLATION	3
TO REMOVE THE EXISTING PUMP ASSEMBLY	3
TO CONNECT THE NEW PUMP ASSEMBLY	4
TO MOUNT THE NEW PUMP ASSEMBLY	5
REPLACEMENT PARTS.....	6
LIMITED WARRANTY	7
ABOUT THE LIMITED WARRANTY	7
Obtaining Warranty Service or Repair Service	7

SPECIFICATIONS

Stock Number	93244	93244AM
Power Source	120 volts AC, 6 amps	240 volts AC, 3 amps
Vacuum Pump	Wobble piston type, 5 SCFM [142 liters/minute] nominal airflow	
 Operating Elevation	Up to 6,000' [1,828 m]	
 Operating Temperatures	32° — 104° F [0° — 40° C]	

Note: Before installing the Wobble Piston Pump Conversion Kit read, understand and follow the lifter's OPERATING INSTRUCTIONS except when directed differently in these installation instructions. Intended use, operation, storage, inspections, tests and maintenance in the lifter's instructions should be understood to include options and conversions, when relevant. All warnings in the "SAFETY" section, as well as alerts in other sections, are applicable when using a converted lifter.

INSTALLATION

TO REMOVE THE EXISTING PUMP ASSEMBLY

- 1) Place the lifter's power switch in the "off" position (○ — fig. 1A).



- 2) Disconnect the lifter's power cable from the power source (figs. 2A-B).

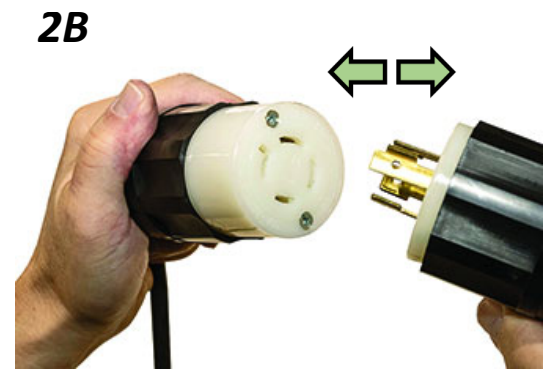

- 3) Remove the existing AC pump assembly from its mounting location.
- 4) Carefully disconnect the vacuum hose and wiring connected to the existing power system.

INSTALLATION

TO CONNECT THE NEW PUMP ASSEMBLY



Wiring must be performed by qualified service personnel, taking all appropriate safety precautions.

- 1) Connect wiring between the lifter's power switch and the new power system: Open the switch enclosure, route wires through the strain relief, and connect wires according to the wiring diagram (see *ENGINEERING DRAWINGS* in the lifter's *OPERATING INSTRUCTIONS* booklet).
- 2) Wire the female electrical connector to an appropriate, current-protected power source, according to the wiring diagram (see *ENGINEERING DRAWINGS* in the lifter's *OPERATING INSTRUCTIONS* booklet).



Power source must be equipped with ground fault circuit interrupter.

Note: See the lifter's serial number plate for power requirements.

- 3) Connect the lifter's vacuum hose to the vacuum side of the pump (see arrow in fig. 3A).

3A

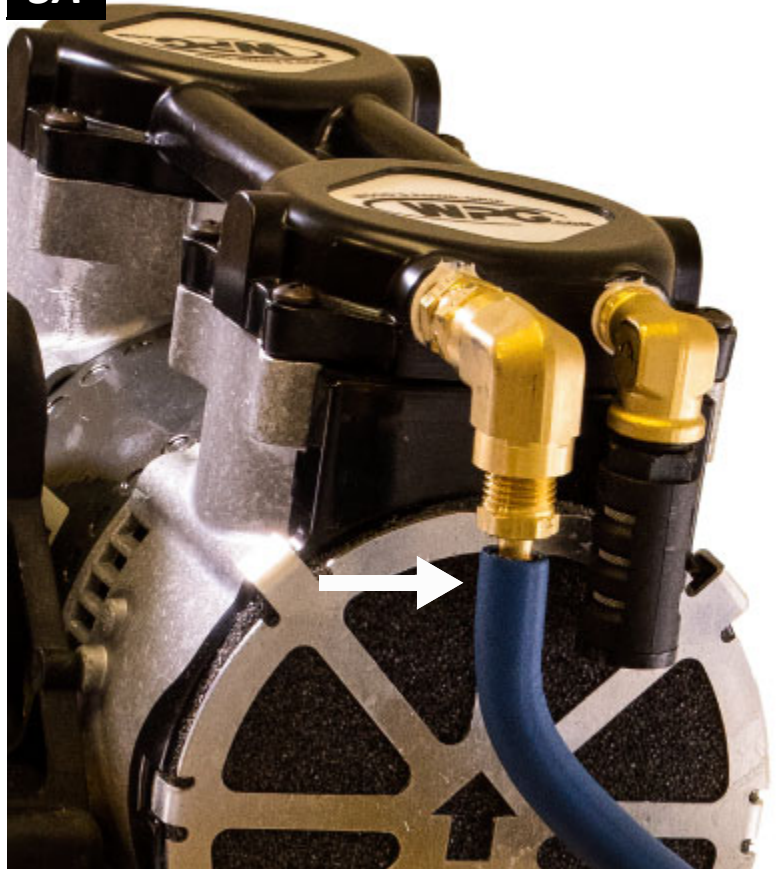

INSTALLATION

To MOUNT THE NEW PUMP ASSEMBLY

- 1) Attach the pump assembly securely to the hoisting equipment in a protected location so that the pump assembly moves with the lifter and will not interfere with hoisting equipment (eg, on trolley for overhead system; see arrows in figs. 1A-B).

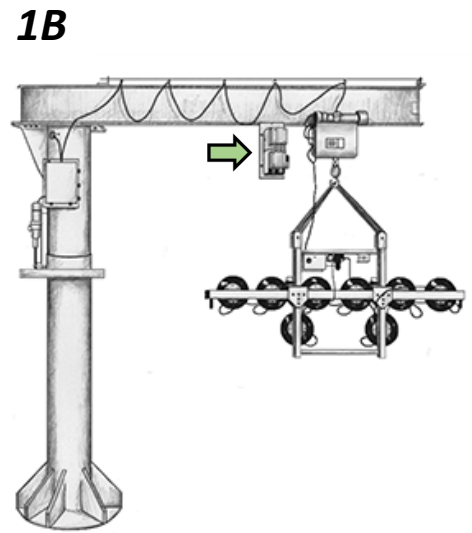
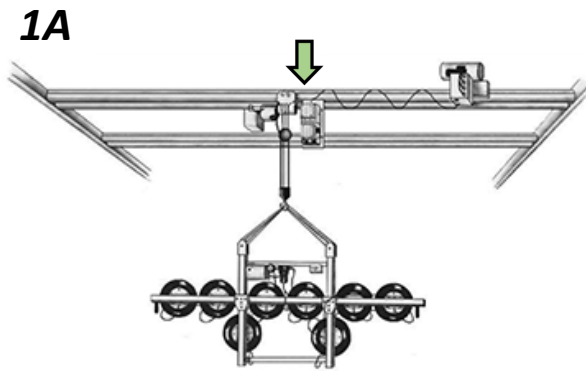

- 2) Route the vacuum hose and wiring between the lifter and the pump assembly to avoid damage while operating the lifter or hoisting equipment.
- 3) Route the power cable between the pump assembly and power source to avoid damage while operating the lifter or hoisting equipment.

- 4) Insert the power cable's male connector into the female connector and twist to secure them together (figs. 4A-B).

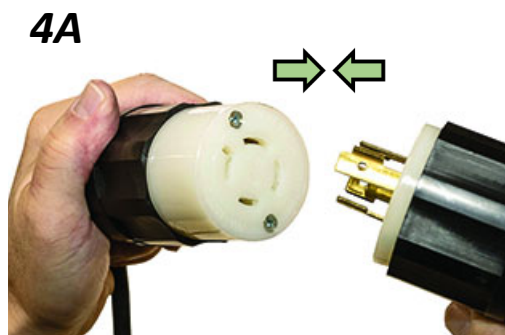

- 5) Perform the "Vacuum Test" (see "INSPECTIONS AND TESTS: TESTING" in the lifter's OPERATING INSTRUCTIONS).

REPLACEMENT PARTS

Stock No.	Description	Qty.
66179AM	Pump Service Kit (for pumps 66126, 66126AM)	1
66126AM	Vacuum Pump – Wobble Piston – 5 SCFM – 240 V AC	1
66126	Vacuum Pump – Wobble Piston – 5 SCFM – 120 V AC	1
65436	Vacuum Hose – 1/4" ID x 1/2" OD	*
65212	Check Valve – 1/4 MNPT – 1.0 PSI Cracking Pressure	1
64458AM	Circuit Breaker – 3 amp (for 240 V AC)	1
64458	Circuit Breaker – 6 amp (for 120 V AC)	1
16100AM	Muffler – 1/4 NPT – 85dB	1

* — Length as required; sold by the inch (approx 2.5 cm).

***SERVICE ONLY WITH IDENTICAL REPLACEMENT PARTS,
AVAILABLE AT WPG.COM OR THROUGH AN AUTHORIZED WPG DEALER***

LIMITED WARRANTY

ABOUT THE LIMITED WARRANTY



Note: Read the [WARRANTY RETURN FORM](#) at [wpg.com](#) for important details about the Limited Warranty.

Wood's Powr-Grip® (WPG) products are warranted to be free from defects in manufacturing and materials for 1 year from the date of purchase.

If a problem develops during the warranty period, follow the instructions below to obtain warranty service. If inspection shows that the product has a defect, WPG will repair or replace the product without charge.



Obtaining Warranty Service or Repair Service

For customers in the U.S. and Canada: Go to the [EXCHANGES, REPAIRS, & WARRANTIES](#) page at [wpg.com](#) and click the applicable link. Alternatively, you may contact the WPG Technical Service Department (see contact information below).

For customers in all other localities: Contact the WPG Technical Service Department (see contact information below) or your dealer for assistance.

ADDRESS	EMAIL	PHONE
Wood's Powr-Grip Co., Inc. 908 West Main St. Laurel, MT USA 59044	contactus@wpg.com	(1) 800-548-7341 (1) 406-628-8231

