

KEEP FOR FUTURE REFERENCE



**P.O. Box 368 – 908 West Main
Laurel, MT USA 59044
phone 800-548-7341
phone 406-628-8231
fax 406-628-8354**

INSTRUCTIONS

International Version

MODEL NUMBERS: CFPT49ACS, CFPT69ACS

SERIAL NUMBER: _____
(please see serial label and record number here)

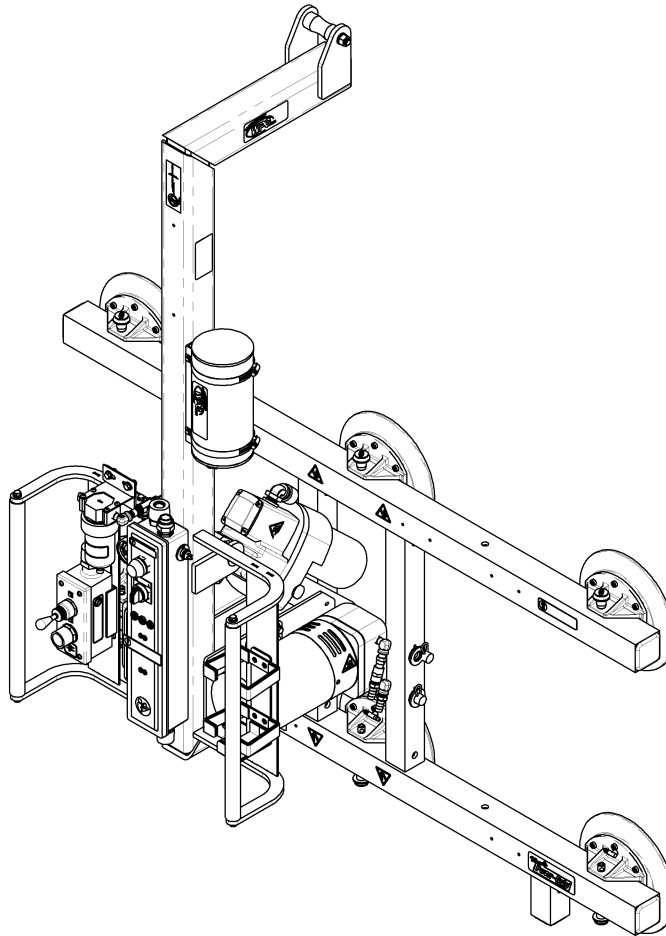

**C-FRAME POWER TILTER
AC-VOLTAGE**



***READ ALL INSTRUCTIONS AND WARNINGS
BEFORE OPERATING THIS LIFTER***



DESIGNED FOR THE MATERIALS HANDLING PROFESSIONAL

TABLE OF CONTENTS

SPECIFICATIONS	3
WARNINGS	4
OPERATING FEATURES	5
ASSEMBLY	6
INTENDED USE	7
LOAD CHARACTERISTICS	7
OPERATING ENVIRONMENT	8
DISPOSAL OF THE LIFTER	8
OPERATION	9
BEFORE USING THE LIFTER	9
Taking Safety Precautions	9
Performing Inspections and Tests	9
TO CHANGE PAD POSITIONS	9
CFPT49ACS PAD FRAME	10
CFPT69ACS PAD FRAME:	10
TO APPLY THE PADS TO A LOAD	11
Generating Vacuum Flow.....	11
Positioning the Lifter on the Load	11
Reading the Vacuum Gauge	12
Vacuum Level on Optimal Surfaces	12
Vacuum Level on Other Surfaces	12
TO LIFT AND MOVE THE LOAD	13
Load Capacity and the Lift Light.....	13
Monitoring Vacuum Indicators	13
Controlling the Lifter and Load.....	13
In Case of Power Failure	14
TO TILT THE LOAD	14
TO RELEASE THE PADS FROM THE LOAD	14
AFTER USING THE LIFTER	15
Storing the Lifter.....	15
MAINTENANCE	16
INSPECTION SCHEDULE	16
Every-Lift Inspection	16
Frequent Inspection	16
Periodic Inspection	16
Infrequent Use	17
TESTING SCHEDULE	17
Operational Tests.....	17
Load Test.....	17

MAINTENANCE SCHEDULE.....	17
VACUUM PAD MAINTENANCE.....	18
Friction Coefficient	18
Inspection	18
Cleaning	19
VACUUM TEST	19
AIR FILTER MAINTENANCE – LARGE	20
Filter Function and Conditions Requiring Service	20
Filter Service Procedures	20
VACUUM PUMP MAINTENANCE – GAST 0523-101Q-SG588DX.....	21
Disassembly/Reassembly Procedure	21
LINEAR TILT ACTUATOR	22
REPLACEMENT PARTS LIST	22
LIMITED WARRANTY	24

SPECIFICATIONS

Description:	Designed for use with a crane or other hoisting equipment, the CFPT4/69ACS lifters employ vacuum to hold a load for lifting, and provide powered 90° tilt movement for load manipulation.	
Model Number:	CFPT49ACS (4 pads)	CFPT69ACS (6 pads)
Maximum Pad Spread: (to outer edges)	33" x 39.5" [84 cm x 100 cm]	33" x 59" [84 cm x 150 cm]
Lifter Weight:	240 lbs [109 kg]	260 lbs [118 kg]
Load Capacity: Per-Pad: Maximum:	(rated at 16" Hg [-54 kPa] on clean, smooth, nonporous flat surfaces ¹) 125 lbs [56.5 kg] 500 lbs [225 kg]	
Vacuum Pads:	9" [23 cm] nominal diameter (Model VPFS9), standard rubber, spring-mounted for 1/4" [7 mm] travel, with #60 filter screen	
Power Source:	120 volts AC, 60 hertz, 12 amps	
C-Frame Design:	C-shaped lift bar permits load transfers directly into and out of open shipping container.	
Tilt Capability:	Powered, 90°; Speed = approx. 6.5 seconds; Duty = 81 tilts per hour	
Vacuum Pump:	Rotary vane type, 4 SCFM [113 liters/minute] nominal airflow	
Vacuum Reserve Tank:	Vacuum reservoir helps prevent immediate vacuum loss in case of power failure.	
Vacuum Gauge:	Dial gauge indicates current vacuum level in positive inches of Hg and negative kPa.	
Vacuum Lift Light:	Green light is energized whenever vacuum level is sufficient for lifting maximum load weight (higher than 16" Hg [-54 kPa]).	
Options:	<i>Available</i> with various pad frame options. See ASSEMBLY: PAD FRAME OPTIONS for alternative Pad Spread dimensions. See separate instructions about optional features.	
Operating Elevation:	Maximum = 10,000 feet [3048 meters]	
Operating Temperatures:	32° to 100° F [0° to 38° C]	
Service Life:	This lifter is designed to have a service life of at least 20,000 lifting cycles, when used and maintained as intended. Vacuum pads, filter elements and other wear-out items are excluded; see MAINTENANCE and REPLACEMENT PARTS LIST for more information. For the DISPOSAL OF THE LIFTER after its service life, see INTENDED USE.	
ASME Standard BTH-1:	Design Category "B", Service Class "0" (see www.WPG.com for more information)	

!!-CE-!! Note: This symbol appears in the *INSTRUCTIONS* manual only when requirements of a CE Standard are *different* from requirements of other standards that also apply to this vacuum lifter. CE requirements are mandatory in geographical areas where CE Standards apply, but may be optional in other locations.

¹ Load Capacity is based on a friction coefficient of 1; see MAINTENANCE: VACUUM PAD MAINTENANCE: Friction Coefficient for additional information.

WARNINGS



Powr-Grip is pleased to offer the most reliable vacuum lifters available. Despite the high degree of security provided by this product, certain precautions must be observed to protect the operator and others.



Always wear personal protective equipment that is appropriate for the material being handled. Follow trade association guidelines.

Always operate the lifter under conditions approved for its design (see INTENDED USE: OPERATING ENVIRONMENT).

Never operate a lifter that is damaged, malfunctioning, or missing parts.

Never operate a lifter if the sealing edge of any vacuum pad is cut or otherwise damaged.

Never remove or obscure warning labels.

Never operate a lifter if the Load Capacity or any warning appears to be missing or obscured.

Always make certain the contact surfaces of the load and all vacuum pads are clean prior to applying the pads (see MAINTENANCE: VACUUM PAD MAINTENANCE).

Never exceed the Load Capacity or attempt to lift loads the lifter is not designed for (see INTENDED USE: LOAD CHARACTERISTICS).

Never attempt to lift cracked or broken glass with this lifter.

Always position the vacuum pads correctly on the load prior to lifting (see OPERATION: TO APPLY THE PADS TO A LOAD).

Never lift a load when any vacuum indicator shows inadequate vacuum.

Never touch the vacuum release controls during a lift. This may result in loss of vacuum and release of the load.

Never allow people to ride on the lifter or the load being lifted.

Never lift a load higher than necessary or leave suspended loads unattended.

Never lift a load over people.

Always keep other personnel far enough away from the lifter to avoid injury in the event of an unexpected load release.

Always place the power control in the inactive position and, when possible, disconnect the power source before opening any enclosure on the lifter. (Only applicable to powered lifters)

Always remember that modifications to the lifter may compromise its safety. Wood's Powr-Grip cannot be responsible for the safety of a lifter that has been modified by the customer. For consultation, contact Wood's Powr-Grip (see LIMITED WARRANTY).

OPERATING FEATURES

Note: Components featured in the following instructions for assembling, operating or maintaining the vacuum lifter are underlined> on their first appearance in each section

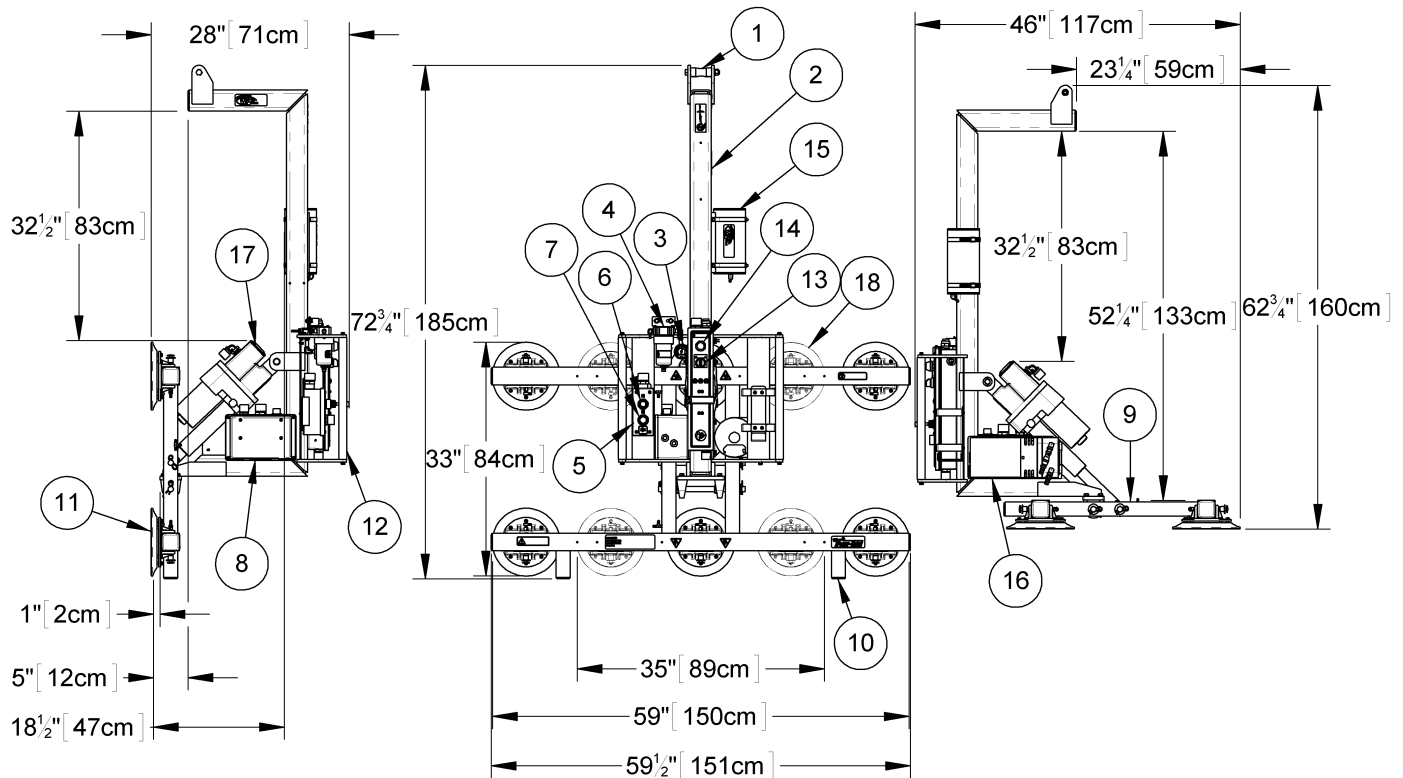

Standard CFPT69ACS shown.

- | | | |
|---------------------------|--------------------------------|-----------------------------|
| 1 LIFT SPOOL | 7 VACUUM RELEASE BUTTON | 13 POWER SWITCH |
| 2 LIFT BAR | 8 Enclosure with VACUUM SWITCH | 14 VACUUM LIFT LIGHT |
| 3 VACUUM GAUGE | 9 PAD FRAME | 15 VACUUM RESERVE TANK |
| 4 AIR FILTER | 10 PARKING FOOT | 16 VACUUM PUMP |
| 5 MOVABLE CONTROL PENDANT | 11 VACUUM PAD with | 17 TILT ACTUATOR |
| 6 TILT TOGGLE SWITCH | MOVABLE PAD MOUNT | 18 ALTERNATIVE PAD POSITION |
| | 12 CONTROL HANDLE | |

ASSEMBLY

- 1) Open the shipping container and remove all materials for restraining or protecting the vacuum lifter. Save the container for use whenever the lifter is transported.
- 2) Connect the power cable from the lifter to the power source: Identify the label indicating the voltage range (V) and frequency (Hz) required to power the lifter (located where power cable connects to lifter). Wire the female connector to appropriate current-protected power source.

 **WARNING: Wiring must be done by qualified personnel, taking all appropriate safety precautions.**

Note: Be advised that brown-outs, overtaxed generators, extension cords, and other conditions can reduce power input to lifter.

 **WARNING: Lifter that does not receive adequate power while lifting could experience unexpected load release.**

 **WARNING: Power source must be equipped with ground fault circuit interrupter to reduce risk of electrical shocks.**

Make certain the power cable is routed so it does not become tangled during operation. Connect the power cable's male and female connectors and twist to secure them together.

- 3) Suspend the lifter from a crane: Select hoisting equipment (i.e. crane and hoist) rated to carry the maximum load weight plus the lifter weight (see SPECIFICATIONS: Maximum Load Capacity and Lifter Weight).

Note: Any application of the lifter must conform to all geographic statutory or regulatory standards that relate to the hoisting equipment (eg, relevant OSHA standards in the USA).

CAUTION: Always provide manual assistance to tilt actuator when raising lift bar to vertical position.

Raise the lift bar to a vertical orientation: Engage the tilt actuator as though tilting to the flat position (see OPERATION: TO TILT THE LOAD); at the same time, manually lift on the lift bar to assist the tilt actuator's movement, and to avoid damaging the actuator.

Attach the hoisting equipment hook to the lift spool and use the hoisting equipment to raise the lifter out of the shipping container. Be careful to avoid damaging any vacuum pads.

 **WARNING: Hoisting equipment hook must be fitted with restraining latch to prevent lift spool from slipping off under any circumstances.**

Note: Some hoisting equipment hooks could interfere with an upright load that extends beyond the lifter's pad frame. If so, the operator must prevent this by attaching a sling (or other rigging that does not interfere with the load) between the hook and the lift spool.

 **WARNING: Any sling used must be rated to carry maximum load weight plus lifter weight.**

A hoist control pendant can be attached to the lifter by inserting it into the pendant basket. Remove the pad covers and save for use when storing lifter. Now the lifter is operational.

- 4) Perform Operational and Load Tests for the lifter as directed in MAINTENANCE: TESTING SCHEDULE.

INTENDED USE

LOAD CHARACTERISTICS

 **WARNING: This lifter is NOT intended for lifting hazardous materials, such as explosives or radioactive substances.**

The operator must verify that the lifter is intended to handle each load, in accordance with the following requirements:

- The load must not exceed the maximum allowable weight specified under Load Capacity (see SPECIFICATIONS).
- The load must be a single piece of nonporous or semiporous material with a flat and relatively smooth contact surface.² To determine whether the load is too porous or rough, perform the test under Vacuum Level on Other Surfaces (see OPERATION: TO APPLY THE PADS TO A LOAD).
- The load's contact surface must be suitable for obtaining a friction coefficient of 1 with the lifter's vacuum pads (see MAINTENANCE: VACUUM PAD MAINTENANCE: Friction Coefficient), as verified by a friction test, or capacity should be derated appropriately. If necessary, contact Wood's Powr-Grip for help in conducting a friction test.
- In order to avoid damaging the vacuum pads, the load's surface temperature must not exceed the allowable Operating Temperatures (see SPECIFICATIONS). However, if such an application cannot be avoided, Wood's Powr-Grip does offer a heat-resistant rubber compound and other solutions which may enable you to lift loads with higher surface temperatures. Contact Wood's Powr-Grip or an authorized dealer for more information.
- While the *minimum* length and width of the load are determined by the Pad Spread (see SPECIFICATIONS), the *maximum* length and width are determined by the allowable overhang, or the amount of load material that can extend sideways beyond the vacuum pads without breaking or otherwise being damaged.

The allowable overhang depends on the kind of load material being lifted, the thickness of the material, and the angle at which it is handled (if any). Since materials such as glass, stone or sheet metal each have different physical properties, the allowable overhang must be evaluated separately for each type of load. If necessary, contact Wood's Powr-Grip or an authorized dealer for help in determining the recommended overhang in a specific situation.

- 1" [2.5 cm] is the maximum allowable thickness of loads at the maximum weight (see SPECIFICATIONS: Load Capacity). However, allowable thickness increases as load weight decreases. If necessary, contact Wood's Powr-Grip for help in determining the maximum thickness permitted when handling any specific load.

Note: Vacuum pads can stain or deform load surfaces with light colors or soft coatings. The operator should test such surfaces for detrimental effects before using the lifter on them.

² Lifters that feature concave vacuum pads can also attach to some kinds of curved loads. Since curvature affects the lifting capacity, contact Wood's Powr-Grip for help in determining the Load Capacity for a particular curved load.

OPERATING ENVIRONMENT

The operator must determine whether the lifter is intended to be used in each work environment, in accordance with the following restrictions:

 **WARNING: Never use lifter in dangerous environments.**

- This lifter is not intended for use in any environment that is inherently dangerous to the operator or likely to compromise the lifter's ability to function. Environments containing explosives, caustic chemicals and other dangerous substances must be avoided when using the lifter.
- The lifter's work environment is limited by the Operating Elevation and Operating Temperatures indicated in SPECIFICATIONS.
- The lifter's work environment must be free of metal particles or any other contaminants that could damage lifter components through airborne contact or any other means of transmission in the environment. If such contaminants cause a vacuum pump failure, they could result in a load release and possible injury to the operator or others nearby.

 **WARNING: Environmental contaminants could result in vacuum pump failure.**

- Using the lifter in wet environments may require the operator to take special precautions: Moisture on contact surfaces of the load or vacuum pads diminishes the lifter's slip resistance, thereby reducing the lifting capacity (see MAINTENANCE: VACUUM PAD MAINTENANCE: Friction Coefficient).

 **WARNING: Moisture reduces slip resistance of vacuum pads.**

Although the lifter's exterior surfaces can tolerate some exposure to water vapor, they are not designed to be water-tight. Submerging the lifter or using it in rain may damage lifter components; these and similar conditions must be avoided.

-
- **!!-CE-!!** If the lifter is employed in a construction area, CE Standard EN 13155 requires the use of a secondary positive holding device, such as a sling system, designed to support the load in case of a vacuum system failure.

 **WARNING: Where CE Standards apply, secondary positive holding device is required for lifting loads in construction zones.**

DISPOSAL OF THE LIFTER

After the vacuum lifter has reached the end of its service life, you must dispose of the lifter in compliance with all local codes and regulatory standards that are relevant for the geographical region.

OPERATION

BEFORE USING THE LIFTER

Determine if the lifter is capable of performing each intended task, following the SPECIFICATIONS and INTENDED USE instructions. Complete the following preparations as well:

Taking Safety Precautions

The operator must be trained in all relevant industry and regulatory standards for the operation of the vacuum lifter in its geographical location (eg, ASME B30.20 in the USA).

Read and understand this manual, including all **WARNINGS**, before using the lifter. If necessary, contact Wood's Powr-Grip or an authorized dealer for assistance.

 **WARNING: Always wear appropriate personal protective equipment.**

The operator must wear any personal protective equipment and take any other precautions required to handle the load safely. Consult appropriate trade association guidelines to determine what precautions are necessary for each type of load material.

Performing Inspections and Tests

Perform all inspections and tests required by the INSPECTION and TESTING SCHEDULES (see MAINTENANCE). In addition, if the lifter has been in storage, always conduct a VACUUM TEST before placing it in service (see MAINTENANCE).

CAUTION: Examine the air filter regularly, and empty when necessary.

The lifter is equipped with an air filter to help protect the vacuum system from contaminants.³ In order for a filter to function, the operator must empty the filter bowl before enough liquid accumulates to contact any portion of the filter element (see MAINTENANCE: AIR FILTER MAINTENANCE).

TO CHANGE PAD POSITIONS

The lifter can accommodate various load dimensions, depending on the position of the movable pad mounts on the pad frame. Move the pad mounts inward or outward on the pad frame as needed to provide adequate support across the load surface. The pad mounts must be arranged symmetrically, to keep the lifter balanced.

 **WARNING: Make sure vacuum hoses are coiled or routed so they do not become damaged.**

To position a pad mount, remove the cotterless hitch pin from the pad frame. While making sure the vacuum hose does not get pinched, move the pad mount to the desired position and align the holes for the pin. Push the pin through the holes until the retaining ball emerges on the far side of the mount. On the opposite side of the pad frame, position the corresponding pad mount at an equal distance from the center of the lifter. Before applying the vacuum pads to a load, make sure that all vacuum hoses are routed correctly and will not interfere with lifter operation.

³ In order for the operator to use the lifter on wet load surfaces, it must be equipped with 2 or more filters that are connected *in series*. However, see MAINTENANCE: VACUUM PAD MAINTENANCE: Friction Coefficient before using the lifter on wet load surfaces.

CFPT49ACS PAD FRAME

The following Pad Spread dimensions are possible for the CFPT49ACS Lifter when equipped with the standard pad frame:

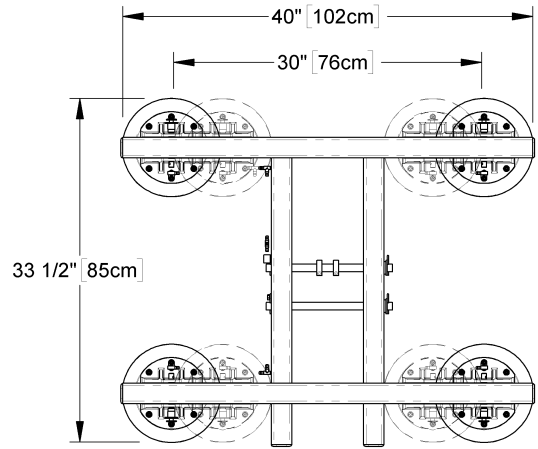

CFPT69ACS PAD FRAME:

The following Pad Spread dimensions are possible for the CFPT49ACS Lifter when equipped various pad frame options:

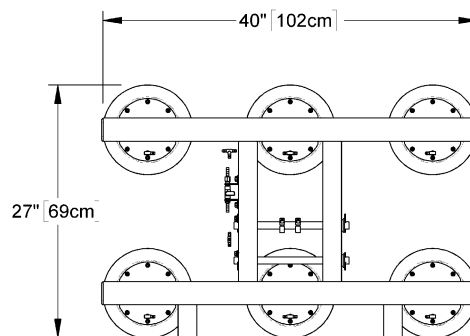
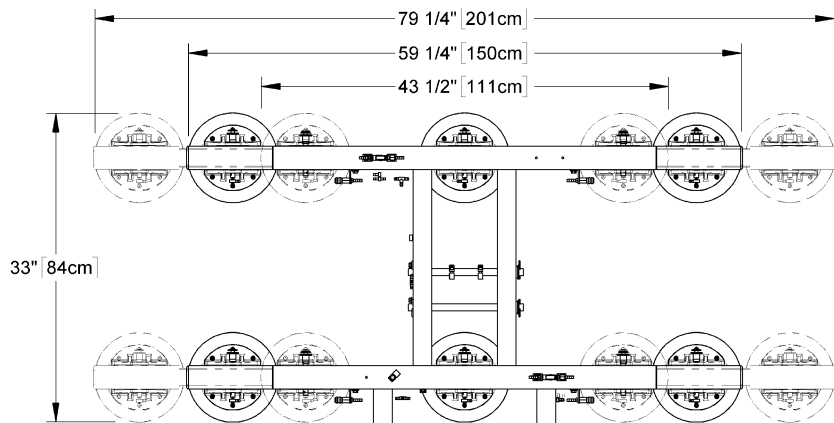
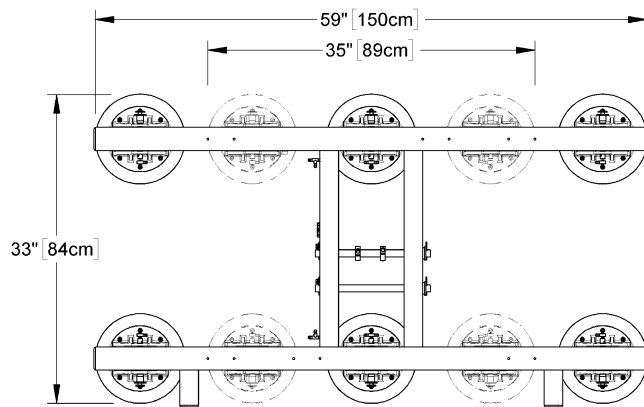

TO APPLY THE PADS TO A LOAD

Generating Vacuum Flow

Place the power switch in the “on” () position. This engages the vacuum pump, causing air to be drawn immediately at the vacuum pads.⁴

 ***WARNING: Never turn power off during operation; keep pump running throughout lift.***

The lifter is designed for the vacuum pump to run continuously. Placing the power switch in the “off” () position during lifter operation could result in the release of the load and possible injury to the operator (see TO LIFT AND MOVE THE LOAD: In Case of Power Failure to follow).

Positioning the Lifter on the Load

Make certain that the contact surfaces of the load and all vacuum pads are free of any contaminants that could prevent the pads from sealing against the load (see MAINTENANCE: VACUUM PAD MAINTENANCE).

Center the lifter’s pad frame to within 2" [5 cm] of the load center, since off-center loading can interfere with the lifter’s tilt capability (see TO TILT THE LOAD to follow), and it may also damage the lifter.⁵ Make sure that all vacuum pads will fit entirely on the load’s contact surface (see SPECIFICATIONS: Maximum Pad Spread) and that they will be loaded evenly while lifting (see SPECIFICATIONS: Per-Pad Load Capacity). Then apply the lifter to the load until all pads seal against the contact surface.

Note: If a vacuum pad has been lying against a hard object (as during shipping), it may be slightly distorted. Although initially it may be difficult to apply the pad to a load, this condition should correct itself with continued use.

 ***WARNING: Do not disconnect control pendant during lifter operation.***

The movable control pendant is not intended to be disconnected during lifter operation. Disconnecting the control pendant is likely to result in a load release and injury to the operator or others nearby.

⁴ If the vacuum pump or any other powered component fails to function while the power switch is in the “on” position, make sure the lifter is connected correctly to an appropriate power source, as directed in the ASSEMBLY section. If so, examine each circuit breaker (adjacent to power switch) to determine whether it has interrupted the electrical circuit to the component. Although the operator can reset the circuit breaker, the power interruption may indicate an electrical problem that requires attention. Correct any deficiency before resuming normal operation of the lifter (see wiring diagram provided).

⁵ The lifter is designed to handle the maximum load weight (see SPECIFICATIONS: Maximum Load Capacity) when the load’s center of gravity is positioned within 2" [5 cm] of the pad frame’s center point. Occasional loading deviations are permissible, provided that the operator can maintain control of the load at all times and that the load weight is low enough to avoid damaging the lifter.

Reading the Vacuum Gauge

The vacuum gauge indicates the current vacuum level in the lifter's vacuum system. The *green* range indicates vacuum levels sufficient for lifting the maximum load weight, whereas the *red* range indicates vacuum levels that are **not** sufficient for lifting the maximum load weight. The gauge needle should show a sudden surge in vacuum as the vacuum pads seal against the load. If it takes more than 5 seconds for the vacuum level to reach 5" Hg [-17 kPa], press on any pad that has not yet sealed.

Vacuum Level on Optimal Surfaces

When the lifter is attached to clean, smooth, nonporous load surfaces, it should be able to maintain a vacuum level in the green range on the vacuum gauge, except when used at high elevations (see SPECIFICATIONS: Operating Elevation). If not, perform the VACUUM TEST (see MAINTENANCE) to determine whether there is a deficiency in the vacuum generating system.

Vacuum Level on Other Surfaces

When the lifter is attached to contaminated, rough or porous load surfaces, it may not be able to maintain a vacuum level in the green range on the vacuum gauge, due to leakage in the seal between the vacuum pads and the load surface. In the case of contamination, thoroughly clean the contact surfaces of the load and the vacuum pads (see MAINTENANCE: VACUUM PAD MAINTENANCE: Cleaning), and reapply the lifter to the load. If the load has rough or porous surfaces, ***the operator must conduct a test to determine whether the lifter is designed to lift the load***, as follows:

- 1) Make sure the lifter's vacuum generating system is functioning correctly (see MAINTENANCE: VACUUM TEST).
- 2) Apply the vacuum pads to the load as previously directed.
- 3) When the vacuum level registers above 16" Hg [-54 kPa] on the vacuum gauge (see TO LIFT AND MOVE THE LOAD: Load Capacity and the Lift Light to follow), place the power switch in the "off" () position.
- 4) Raise the load a minimal distance, to assure that it is supported by the lifter.
- 5) Monitor the vacuum gauge while the load is suspended for 5 minutes: ***The lifter must maintain a minimum vacuum level of 10" Hg [-34 kPa] during this time.*** If not, the load does not possess the characteristics required for using this lifter.⁶

⁶ Certain load materials are too rough or porous to allow the lifter to form a seal which can be maintained for 5 minutes without power. However, in geographical locations where CE Standards do not apply, it may be possible to use the lifter to lift such loads. Contact Wood's Powr-Grip for more information.

TO LIFT AND MOVE THE LOAD



WARNING: Lift bar must be oriented vertically to lift load.

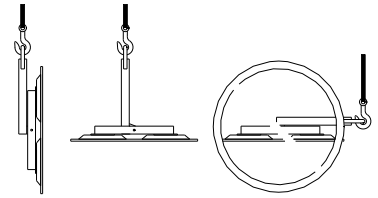

Load Capacity and the Lift Light

A lifter's Load Capacity is rated at a vacuum level of 16" Hg [-54 kPa] (see SPECIFICATIONS). After a lifter has attained this level, the green vacuum lift light turns on to indicate that the lifter is ready to lift the maximum load weight.



WARNING: *Never attempt to lift load unless green lift light is illuminated.*

Do not attempt to lift the load unless the lift light is illuminated; such an attempt could result in a load release and possible injury to the operator.

Monitoring Vacuum Indicators

The vacuum lift light and the vacuum gauge must remain completely visible to the operator, so that they can be monitored throughout the entire lift.



WARNING: *Vacuum indicators must be visible to operator throughout entire lift.*

The lifter's vacuum pump runs continuously to maintain sufficient vacuum for lifting the maximum load weight. If the vacuum system experiences leakage while the lifter is attached to the load, the lift light turns off automatically, to signal the reduction in vacuum to the operator.

If the lift light turns off while you are lifting a load, make sure the vacuum gauge shows a vacuum level of 16" Hg [-54 kPa] or higher. If not, move away and stay clear of the load until it can be lowered to the ground or a stable support.



WARNING: *Stay clear of any suspended load while vacuum level is lower than 16" Hg [-54 kPa].*

Discontinue lifter use until the cause of the vacuum loss can be determined. If the lift light does not turn on when the lifter is attached to clean, smooth, nonporous materials, the leakage is likely to be in the vacuum system. In this event, perform the VACUUM TEST (see MAINTENANCE) and inspect the vacuum pads for damage (see MAINTENANCE: VACUUM PAD MAINTENANCE: Inspection). If the vacuum loss cannot be remedied immediately, perform inspection and maintenance as needed to identify and correct any deficiency before resuming normal operation of the lifter.

Controlling the Lifter and Load

When the vacuum indicators show that the lifter is ready, use the hoisting equipment to raise the lifter and load as needed to clear any obstacles in their path. Use the control handles to keep the lifter and load in the desired orientation while they are suspended from the crane. Once sufficient clearance is established, the load can be tilted as desired (see TO TILT THE LOAD to follow).

Note: The hang angle of the lifter may shift suddenly upon lifting or releasing the load. The operator should anticipate and compensate for such changes.

In Case of Power Failure

The lifter is equipped with a vacuum reserve tank, designed to maintain vacuum temporarily in case of a failure at the lifter's power source.

⚠ WARNING: Stay clear of any suspended load in the event of a power failure.

Although the lifter is designed to support the load for at least 5 minutes without power, this depends on many factors, including the condition of the load and the lifter's vacuum system (see INTENDED USE: LOAD CHARACTERISTICS and MAINTENANCE: VACUUM PAD MAINTENANCE, VACUUM TEST). If a power failure occurs, keep all personnel clear of the suspended load until it can safely be placed on the ground or a stable support. Correct any deficiency before resuming normal operation of the lifter.

To TILT THE LOAD

CAUTION: Make sure load is positioned correctly on lifter (see To APPLY); unbalanced loads may damage lifter.

Remember that the load requires more vertical space when tilted to the upright position, as well as more horizontal space when tilted to the flat position. Make sure there is sufficient clearance for the load to tilt without contacting the operator or any nearby objects. The tilt toggle switch on the movable control pendant controls the powered tilt motion: To tilt the load towards the flat position, push the toggle up; to tilt the load towards the upright position, push the toggle down. Releasing the toggle switch locks the load in any position within the 90° range of tilt movement.

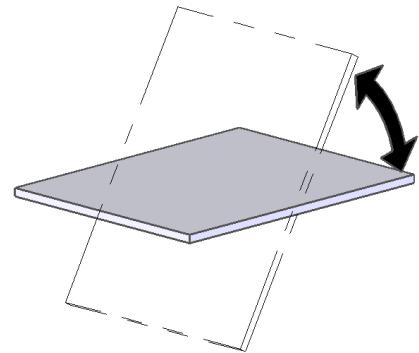

To RELEASE THE PADS FROM THE LOAD

⚠ WARNING: Load must be fully supported before releasing vacuum pads.

When the load is at rest and fully supported, push the vacuum release button on the movable control pendant to force air into the vacuum pads, quickly breaking the vacuum seal. After the pads have disengaged completely from the load, move the lifter away. Continue to hold the release button until the pads are well away from the load; otherwise, the lifter would reattach itself to the load.

AFTER USING THE LIFTER

Place the power switch in the "off" () position.

CAUTION: Do not set the lifter against any surfaces which could soil or damage the vacuum pads.

Built-in parking feet can be used to support an unloaded lifter when not suspended from a crane: Make sure the pad frame is oriented vertically with the parking feet at the bottom. Use the hoisting equipment to gently lower the lifter until the parking feet support its entire weight. Make sure the lifter leans securely against an appropriate support; then detach the hoisting equipment hook from the lift spool.

If the lifter is transported to another location, use the original shipping container and secure the lifter so as to protect the vacuum pads and all other components from damage while in transit.

Storing the Lifter

Use the covers supplied to keep the vacuum pads clean.

.....
!!-CE-!! In accordance with CE Standard EN 13155, the lifter is designed to rest on relatively horizontal surfaces without tipping over. To store the lifter in this way, set the lifter with the pads facing downward on a clean, smooth, flat surface. Then lower the lift bar to a horizontal orientation (see OPERATION: TO TILT THE LOAD) and place a support under the lift spool. However, see the Note immediately following.

.....
Note: Storing the lifter with its pad frame and lift bar in the horizontal orientation could damage the tilt actuator, if the lift bar is not supported. Avoid placing the lifter in this position; or if this is unavoidable, place a support under the lift bar. Also be sure to provide manual assistance to the tilt actuator when raising the lift bar to the vertical position (see ASSEMBLY).

MAINTENANCE

 **WARNING: Make sure power cable is disconnected from power source before servicing lifter.**

Note: One or more wiring diagrams may be provided in the final section of this *INSTRUCTIONS* manual for reference when servicing the lifter or trouble-shooting a deficiency.

INSPECTION SCHEDULE

Perform inspections routinely, according to the following frequency schedule:

Every-Lift Inspection

- Examine the vacuum pads and load surface for contamination or debris (see VACUUM PAD MAINTENANCE to follow).
- Examine the vacuum pads, controls and indicators for visual damage (see VACUUM PAD MAINTENANCE to follow).

If any deficiency is detected during the inspection, correct it before using the lifter and perform the Frequent Inspection to follow.

Frequent Inspection

(following every 20-40 hours' use; or whenever lifter is out of service for 1 month or more)

- Examine the lifter's structure for visual damage.
- Examine the vacuum system (including vacuum pads, fittings and hoses) for visual damage.
- Examine the air filter for conditions requiring service (see AIR FILTER MAINTENANCE to follow).
- Perform the VACUUM TEST to follow.
- Check for unusual vibrations or noises while operating the lifter.

If any deficiency is detected during the inspection, correct it before using the lifter and perform the Periodic Inspection to follow.

Periodic Inspection

(following every 250-500 hours' use; or whenever lifter is out of service for 1 year or more)

- Examine the entire lifter for external evidence of looseness, excessive wear, deformation, cracks, excessive corrosion, dents to structural or functional components, cuts, or any deficiency which might constitute a hazard.
- Inspect all parts of the electrical system for damage, wear or contamination that could constitute a hazard, in compliance with all local codes and regulatory standards that are relevant for the geographical region.

CAUTION: Be sure to use appropriate cleaning methods for each type of electrical component, as specified by codes and standards. Improper cleaning can damage components.

- Keep a written record of all Periodic Inspections.

If any deficiency is detected during the inspection, correct it before using the lifter. If necessary, return the lifter to Wood's Powr-Grip or an authorized dealer for repair (see LIMITED WARRANTY).

Infrequent Use

If a lifter is used less than 1 day in a 2-week period, perform the Periodic Inspection *each time before using the lifter*.

TESTING SCHEDULE

Perform these tests when placing the lifter in service *initially* and *each time following a repair or modification*. Correct any deficiency and retest before using the lifter.

Operational Tests

- Perform the VACUUM TEST to follow.
- Test all features and functions of the lifter (see OPERATING FEATURES, OPERATION and MAINTENANCE).

Load Test

Prove that the lifter can lift 100% of its Maximum Load Capacity (see SPECIFICATIONS), using an actual load or an equivalent simulation.⁷ Employ the following method to test with an actual load:

- 1) Place a test load with appropriate LOAD CHARACTERISTICS (see INTENDED USE) on a stable support. Make sure the load is oriented in the upright position.⁸
- 2) Apply the vacuum pads to the load as previously directed.
- 3) When the vacuum level registers above 16" Hg [-54 kPa] on the vacuum gauge, place the power switch in the "off" position (.
- 4) Raise the load a minimal distance, to assure that it is supported by the lifter.
- 5) Hold the load for 5 minutes. The load must not slip or fall during this time period. If it does, conduct a VACUUM TEST and inspect each vacuum pad as indicated under VACUUM PAD MAINTENANCE: Inspection (see sections to follow). Correct any deficiency that is found and retest the lifter.

Note: See MAINTENANCE topics to follow for additional directions about inspecting and testing specific lifter components.

MAINTENANCE SCHEDULE

Unless specified elsewhere in this *INSTRUCTIONS* manual, the lifter does not require maintenance on a routine basis. Instead, maintenance must be performed whenever a deficiency is indicated by routine inspections or tests. Any maintenance warranted must be performed before resuming normal operation of the lifter.

⁷ ASME Standard B30.20 requires the lifter to be tested to 125% of its Load Capacity.

⁸ Flat Lifters are exempt from this requirement.

VACUUM PAD MAINTENANCE

Friction Coefficient

The friction coefficient represents the lifter's ability to resist load slippage when the load is oriented in any position except horizontal. If the contact surfaces of either the load or the vacuum pads are not clean, dry and in good condition, slippage is more likely to occur.

The Load Capacity of most Powr-Grip lifters is based on a friction coefficient of 1 (only Flat Lifters are exempt from this requirement). However, a vacuum pad's ability to maintain this friction coefficient is reduced by factors such as contamination, wear, age and exposure to sunlight, as well as the condition of the load's contact surface (see INTENDED USE: LOAD CHARACTERISTICS). Pads that have surface contamination must be thoroughly cleaned (see Cleaning discussion to follow). Over time, the rubber in a pad may experience hardening or leaching of chemicals, resulting in stiffness or surface glaze. Pads that exhibit wear, stiffness or glaze must be replaced. In addition, all pads should be replaced on a regular basis, preferably after no more than 2 years, to ensure that the friction coefficient is not compromised. If necessary, contact your dealer or Wood's Powr-Grip for more information.

Inspection

Inspect each vacuum pad for the following deficiencies routinely, as directed in the preceding INSPECTION and TESTING SCHEDULES. Correct any deficiency before using the lifter.

- Contaminates on the pad face or sealing edges: Soil build-up can prevent pads from sealing adequately or reduce the friction coefficient (see discussion preceding). Follow the directions to clean pads as necessary (see discussion to follow).
- Filter screen missing from pad face: This screen helps prevent debris from plugging the vacuum hose and the air filter. Replace any missing screen immediately (see REPLACEMENT PARTS LIST).
- Nicks, cuts or abrasions in sealing edges: Pad damage can reduce the lifting capacity of the lifter. Replace any damaged pad immediately (see REPLACEMENT PARTS LIST).⁹

 **WARNING: Replace vacuum pad if sealing edge has any nicks, cuts or abrasions.**

- Wear, stiffness or glaze: See Friction Coefficient preceding. Replace any pad that exhibits wear, stiffness or glaze (see REPLACEMENT PARTS LIST).

⁹ If the lifter is equipped with VPFS10T or VPFS625 pads, the sealing edge is the replaceable sealing ring. When it is damaged, install a new sealing ring insert. In such cases, see TO REPLACE SEALING RING INSERT IN VACUUM PAD to follow.

Cleaning

Regularly clean the face of each vacuum pad to remove oil, dust and any other contaminants. Acceptable cleaning agents include soapy water and other mild cleansers. Do *not* use solvents, petroleum-based products (including kerosene, gasoline and diesel fuel) or any harsh chemicals for cleaning. Do *not* use unauthorized rubber cleaners or conditioners, such as those intended for cleaning tires or vinyl surfaces, because those products can leave a hazardous film on vacuum pads which significantly reduces their lifting capacity (see Friction Coefficient preceding). The use of any unauthorized cleaning agent is prohibited because it could damage the pad and/or create a hazard to the operator or others.

 **WARNING: Never use solvents, gasoline or other harsh chemicals to clean vacuum pad.**

 **WARNING: Never use unauthorized rubber cleaners or conditioners to clean vacuum pad.**

To prevent liquid from contaminating the vacuum system during cleaning, cover the suction hole in the recess for the filter screen or make sure the pad faces downward. Use a clean sponge or lint-free cloth to apply an authorized cleanser and wipe the pad face clean. A toothbrush (or similar brush with bristles *that do not harm rubber*) may be used to remove contaminants clinging to sealing edges.¹⁰ Wipe all residue from the pad face, and allow the pad to dry completely before using the lifter.

VACUUM TEST

Test the vacuum system for leakage routinely, as directed in the preceding INSPECTION and TESTING SCHEDULES.

- 1) Clean the face of each vacuum pad as previously directed (see VACUUM PAD MAINTENANCE: Cleaning).
- 2) Apply the lifter to a clean, smooth, nonporous surface. The surface should be flat or possess no more curvature than the lifter is designed for (if any).¹¹
- 3) When the vacuum level registers above 16" Hg [-54 kPa] on the vacuum gauge, place the power switch in the "off" position ( and leave the pads attached to the surface.
- 4) Monitor the vacuum gauge: *The vacuum level should not decrease by more than 4" Hg [-14 kPa] in 10 minutes.*

 **WARNING: If lifter fails vacuum test, discontinue use immediately.**

Correct any deficiency in the vacuum system before using the lifter. Contact Wood's Powr-Grip or an authorized dealer for assistance.

¹⁰ If these cleaning methods are not successful, contact Wood's Powr-Grip or an authorized dealer for assistance.

¹¹ Any test material used must be fully and independently supported, and capable of bearing the lifter's weight. Do not use the lifter to lift the test material during the vacuum test.

AIR FILTER MAINTENANCE – LARGE

(For 4.4 oz [130 ml] bowl size filters)

Filter Function and Conditions Requiring Service

An air filter prevents solid particles and liquid from contaminating components in the vacuum system.

CAUTION: Examine air filter regularly and empty when necessary.

Liquid must not contact any portion of the filter element; remove trapped liquid regularly. Replace the element if it has an overall dirty appearance, or if there is a noticeable increase in the time required to attain full vacuum. (Refer to REPLACEMENT PARTS LIST for filter element kit.)

Filter Service Procedures

- 1) Unscrew the threaded collar (8) from the body (1). Support the body while twisting the collar, to protect the vacuum line fittings from being damaged. Then remove the bowl guard (7) and the bowl (6).

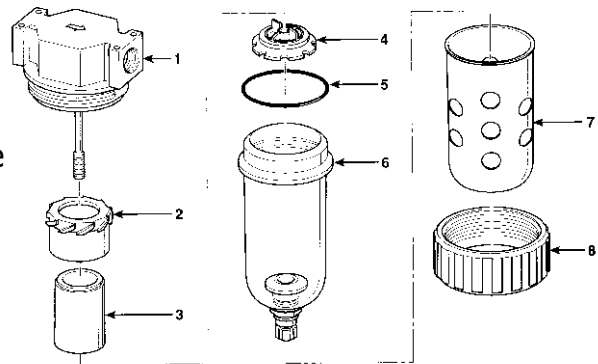

- 2) Determine whether the filter element (3) needs to be replaced (see Conditions Requiring Service preceding). *If so*, proceed to step 3.

If not, remove any liquid or contaminants from the bowl; clean the old bowl seal (5) with mild soap and water; and skip to step 7.

- 3) Unscrew the baffle (4), and remove the element and deflector (2).
- 4) Discard the element and the bowl seal (5).
- 5) Clean all internal parts and the bowl, using mild soap and water only. Do *not* use any other cleaners.
- 6) Install the deflector and a new filter element; then screw the baffle back on (tighten gently, finger tight) to hold the element in place.
- 7) Lubricate the new or cleaned bowl seal, using a mineral base oil or grease (such as the lubricant furnished in the filter element kit). Do *not* use synthetic oils, such as esters, or silicones.
- 8) Place the bowl seal around the rim of the bowl. Then install the bowl on the body, taking care to avoid contaminating the filter element with lubricant.
- 9) Install the bowl guard and the collar, tightening it only hand-tight (28-32 in-lbs [316-362 N-cm] torque).
- 10) Test the vacuum system to be certain the air filter does not leak (see VACUUM TEST preceding, if applicable).

⚠ WARNING: When the air filter is being used on a *vacuum* system, rather than with pressure, using the twist drain to remove liquid from the bowl is *not* recommended. **Never** disturb the twist drain, as contaminants could lodge in the drain seal and cause a vacuum leak.

VACUUM PUMP MAINTENANCE – GAST 0523-101Q-SG588DX

⚠ WARNING: Before proceeding with any maintenance, disconnect power source.

Disassembly/Reassembly Procedure

(includes replacing the air filters, vanes and gasket—see REPLACEMENT PARTS LIST)

- 1) Remove the end caps (10), O-rings (9) and air filters (8) from the sound chamber (6) of the vacuum pump.
- 2) Remove the five bolts (7) and remove the sound chamber (6).
Note: If any liquid is discovered in the sound chamber, thoroughly dry all interior surfaces of the pump prior to reassembly.
- 3) Remove the six bolts (4) from the endplate (3), and separate the endplate from the rotor housing. The shroud (1) surrounding the rotor housing will loosen as well.
- 4) Note the orientation of the bevel on the vanes (2) for step 5. Then remove the vanes by sliding them out the end of the rotor. If needed, rotate the rotor by hand to position the vanes for easier access.
- 5) Make sure that the rotor and housing are clean and free of debris. Orient the new vanes (2) like the old ones by matching the bevel. Then insert the new vanes by sliding them into the empty slots in the rotor.
- 6) Reinstall the endplate (3) and secure it with the six bolts (4) previously removed.
- 7) Remove the gasket (5), and make sure that the contact surfaces between the endplate and sound chamber are clean. Install a new gasket and reinstall the sound chamber (6). Then secure the sound chamber with the five bolts (7) previously removed.
- 8) Replace the air filters (8). Then reinstall the O-rings (9) and end caps (10).

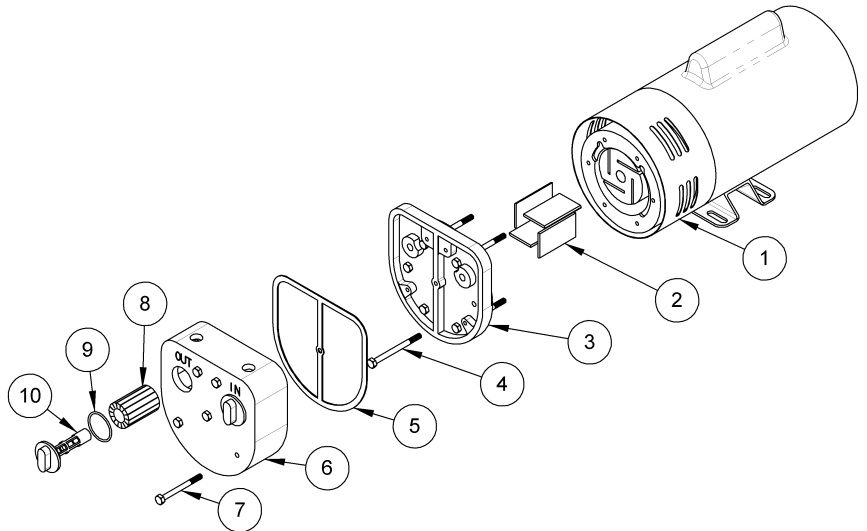

1 SHROUD

2 VANES (4x)

3 ENDPLATE

4 BOLTS FOR ENDPLATE (6x)

5 GASKET

6 SOUND CHAMBER

7 BOLTS FOR SOUND CHAMBER (5x)

8 AIR FILTER (2x)

9 O-RING (2x)

10 END CAP (2x)

LINEAR TILT ACTUATOR

Since the tilt actuator is prelubricated, no additional lubrication is required under normal circumstances.¹²

The actuator has an intermittent-duty type motor and a duty cycle of approximately 20%: If the actuator is operated more than 20% of the time or runs continuously for more than 5 minutes, a thermal overload relay breaks the power circuit. It then takes about 10 minutes before the motor cools sufficiently for the thermal relay to close and restore power.

The brake is preset and should provide consistent braking for the tilt function. In the event that the brake friction surfaces become worn (indicated by excessive drift), contact Wood's Powr-Grip for rebuilding.

The limit switches which control the stroke length also are preset and should not need adjustment. However, if adjustment is required, proceed as follows:

- 1) Remove the appropriate cover plate (on actuator head, facing screw shaft side) to expose the limit switches (1 and 5).
- 2) Engage the actuator until it reaches the correct retracted or extended position (depending on adjustment needed). Stop the actuator before any parts of the vacuum lifter come in contact with each other.
- 3) Remove the nut restrainer (3).
- 4) Turn the appropriate limit switch nut (2 or 4) as needed to activate the limit switch, allowing for drift.
- 5) Check actuator travel and readjust if necessary. Then reinstall the nut restrainer and cover plate.

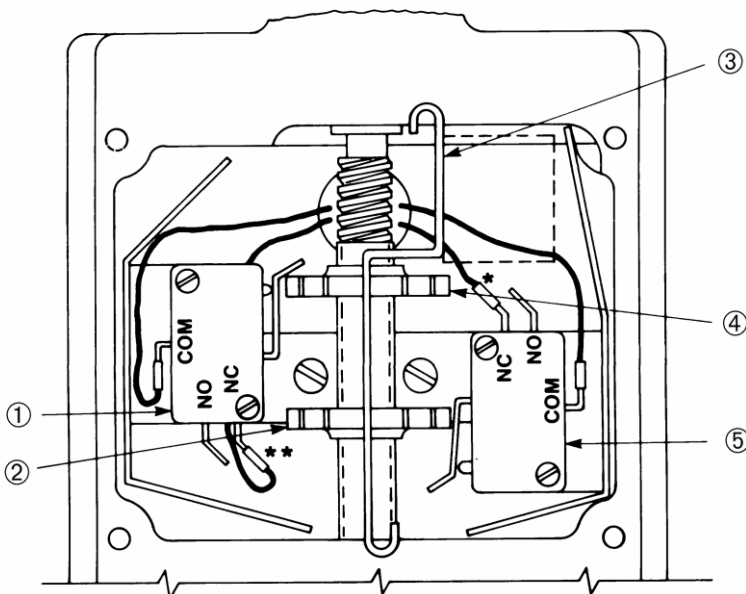

¹² If the actuator is not used for a week or more at a time, oil may begin to separate from the lubricant and leak out. Although this leakage is not detrimental to the lubrication or operation of the actuator, you can avoid this condition by simply running the actuator for a few cycles each week.

REPLACEMENT PARTS LIST

Stock No.	Description	Qty.
95500AM	Vacuum Pump – Rotary Vane Type – 4-SCFM [113 liters/minute] – 100/120/240/ V AC	1
66175AB	Pump Gasket (for rotary vane pump)	1
66175	Pump Vanes & Filters Kit (for rotary vane pump)	1
65444	Vacuum Hose – 1/2" [12.7 mm] ID (approx. 72" [183 cm] in length)	1
65441	Vacuum Hose – 1/4" [6.3 mm] ID x 48" [122 cm] Length – Coiled	4
65440	Vacuum Hose – 1/4" [6.3 mm] ID (approx. 72" [183 cm] in length)	1
65438	Vacuum Hose – 1/8" [3.2 mm] ID (approx. 6" [15 cm] in length)	1
65301	Handle Grip Foam	2
65231	Solenoid Valve – 120 V AC – 6 W	1
65212	Check Valve – 1/4 NPT	1
65211AM	Check Valve – 1/8 NPT	1
65010	Pad Spring – Coil Type	4 / 6
64950	Actuator – 1500 lbs [680 kg] – 6" [152 mm] Stroke – 120 V AC	1
64461	Circuit Breaker – 10 A	1
64459MZ	Circuit Breaker – 8 A	1
64459	Circuit Breaker – 5 A	1
64289	Bulb – 24 V – Bayonet (for vacuum lift light)	1
64262	Green Lens (for vacuum lift light)	1
64236	Vacuum Switch – 1/4 NPT	1
64191	Contact Block (for power switch)	1
56052	Solenoid Valve Manifold Assembly – 24 V AC	1
53132	Hose Fitting – Tee – 5/32" [4.0 mm] ID	3
53120	Pad Fitting – Elbow – 5/32" [4.0 mm] ID with Barbed Stem	4
53126	Pad Fitting – Tee – 5/32" [4.0mm] ID with Barbed Stem (CFPT69ACS only)	2
49506A	Vacuum Pad – Model VPFS9 / 9" [23 cm] Diameter	4 / 6
49180	End Plug – 3" x 3" x 1/4" [76.2mm x 76.2mm x 4.8mm] Tubing Size	1
49150	End Plug – 2-1/2" x 2-1/2" x 1/4" [63.5 mm x 63.5 mm x 6.4 mm] Tubing Size	4
49122	End Plug – 2" x 2" x 1/4" [50.8 mm x 50.8 mm x 6.4 mm] Tubing Size	2
29353	Pad Cover	4 / 6
20270	1/4" [6.4 mm] Open-End Wrench (for adjusting vacuum switch)	1
16132	Filter Element Kit (for 4.4 oz [130 ml] bowl size air filter)	1
15910	Vacuum Gauge – 1/8 NPT – CBM Type	1
15632	Pad Filter Screen – Small	4 / 6
13532	Cotterless Hitch Pin – 1/2" x 3-3/8" (CFPT69ACS only)	6
10900	Shoulder Bolt – Socket Head – 5/16" x 1/2" x 1/4-20 Thread (for mounting pads)	24 / 36

***SERVICE ONLY WITH IDENTICAL REPLACEMENT PARTS,
AVAILABLE AT WPG.COM OR THROUGH AN AUTHORIZED WPG DEALER***

LIMITED WARRANTY

Powr-Grip products are carefully constructed, thoroughly inspected at various stages of production, and individually tested. They are warranted to be free from defects in workmanship and materials for a period of one year from the date of purchase.

If a problem develops during the warranty period, follow the instructions hereafter to obtain warranty service. If inspection shows that the problem is due to defective workmanship or materials, Powr-Grip will repair the product without charge.

WARRANTY DOES NOT APPLY WHEN:

Modifications have been made to the product after leaving the factory.

Rubber portions have been cut or scratched during use.

Repairs are required due to abnormal wear and tear.

The product has been damaged, misused, or neglected.

If a problem is not covered under warranty, Powr-Grip will notify the customer of costs prior to repair. If the customer agrees to pay all repair costs and to receive the repaired product on a C.O.D. basis, Powr-Grip then will proceed with repairs.

TO OBTAIN REPAIRS OR WARRANTY SERVICE

For purchases in *North America*:

Contact the Technical Service Department at Wood's Powr-Grip Co. When factory service is required, ship the complete product—prepaid—along with your name, address and phone number to the street address hereafter.

For purchases in *all other localities*:

Contact your dealer or the Technical Service Department at Wood's Powr-Grip Co. for assistance.

Wood's Powr-Grip Co., Inc.
908 West Main St. / P.O. Box 368
Laurel, MT USA 59044

phone 800-548-7341

phone 406-628-8231

fax 406-628-8354

FILE DIRECTORY:
FILE [SHEET]:

700-W06 [W06]

TYPE:
STANDARD

WIRE LEGEND: CONTROLLED BY
WIRING SYMBOLS DRAWING
EXCEPT AS NOTED AND BELOW.

LINE STYLES AND WIDTHS FOR
WIRE UNLESS NOTED OTHERWISE.

..... N/A N/A 16AWG
- - - - - N/A - - - - - N/A - - - - - N/A
- - - - - N/A - - - - - N/A - - - - - N/A

PRODUCT MANAGER:
GARY B.

DATE:
01/10/2018

CHECKED: *OR*
APPROVED: *OWN*

THIS DRAWING IS THE PROPERTY OF
WOOD'S POWER-GRIP CO., INC.
IT IS LOANED WITH THE UNDERSTANDING THAT NEITHER IT NOR ANY
INFORMATION CONTAINED THEREIN WILL BE COPIED, PUBLISHED OR
TRANSMITTED TO OTHERS WITHOUT EXPRESS WRITTEN PERMISSION.



LAUREL,
MONTANA
U.S.A.

STANDARD PARTS
N/A

4SCFM 100/120/240VAC 50/60HZ ROT VANE VAC PMP WIR SCH
D700-W06 [W06]

SIZE: SCALE: REVISION: ECN NUMBER: ECN DATE: ECN BY: EST. WEIGHT:
A NONE 01.A 4478 01/10/2018 JAC N/A

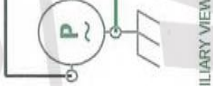
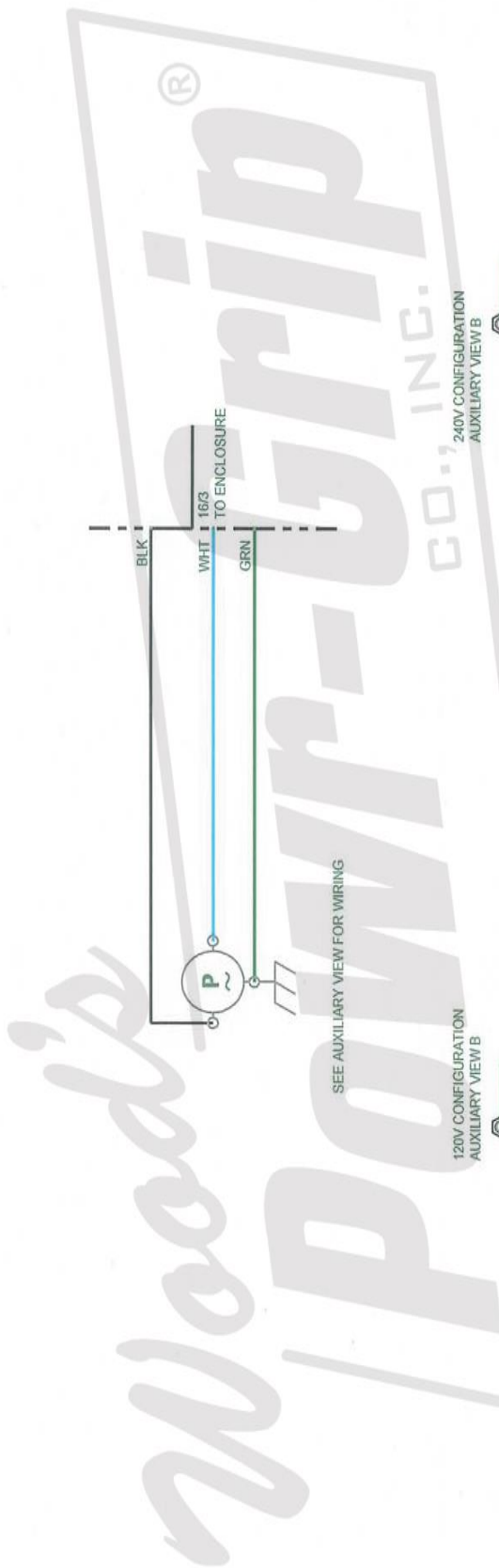

120V CONFIGURATION
AUXILIARY VIEW B

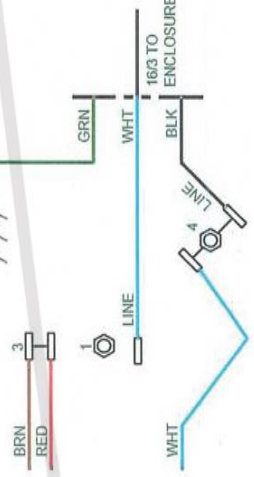

240V CONFIGURATION
AUXILIARY VIEW B

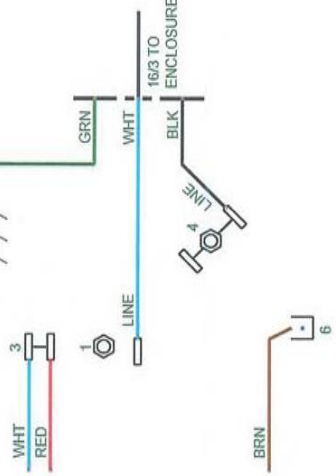

WIRE LEGEND: CONTROLLED BY WIRING SYMBOLS DRAWING EXCEPT AS NOTED AND BELOW. LINE STYLES AND WIDTHS FOR WIRE UNLESS NOTED OTHERWISE. --- 20AWG --- 16AWG --- 14AWG --- N/A		TYPE: STANDARD		DIRECTORY: H:\Working\STD\700-STD\ECN 2762	
DRAWN: L. RENNER		DATE: 05/30/2006		FILE [SHEET]: 700-W02 [W02]	
CHECKED: <i>CR</i>		DATE: 04-02-12		THIS DRAWING IS THE PROPERTY OF WOOD'S POWR-GRIP CO., INC. LAUREL, MONTANA U.S.A. IT IS LOANED WITH THE UNDERSTANDING THAT NEITHER IT NOR ANY INFORMATION CONTAINED THEREIN WILL BE COPIED, PUBLISHED OR TRANSMITTED TO OTHERS WITHOUT EXPRESS WRITTEN PERMISSION.	
APPROVED: <i>Cam</i>		DATE: 4-2-12		STANDARD PARTS N/A	
		DATE: 12/09/2011		BY: LER	
		REV: 2		ECN NUMBER: 2762	
		SCALE: A		SIZE: NONE	
		REV: 2		ECN NUMBER: 2762	
		DATE: 12/09/2011		BY: LER	
120/240VAC GAST 3 SCFM VACUUM PUMP WIRING SCHEMATIC D700-W02 [W02]					

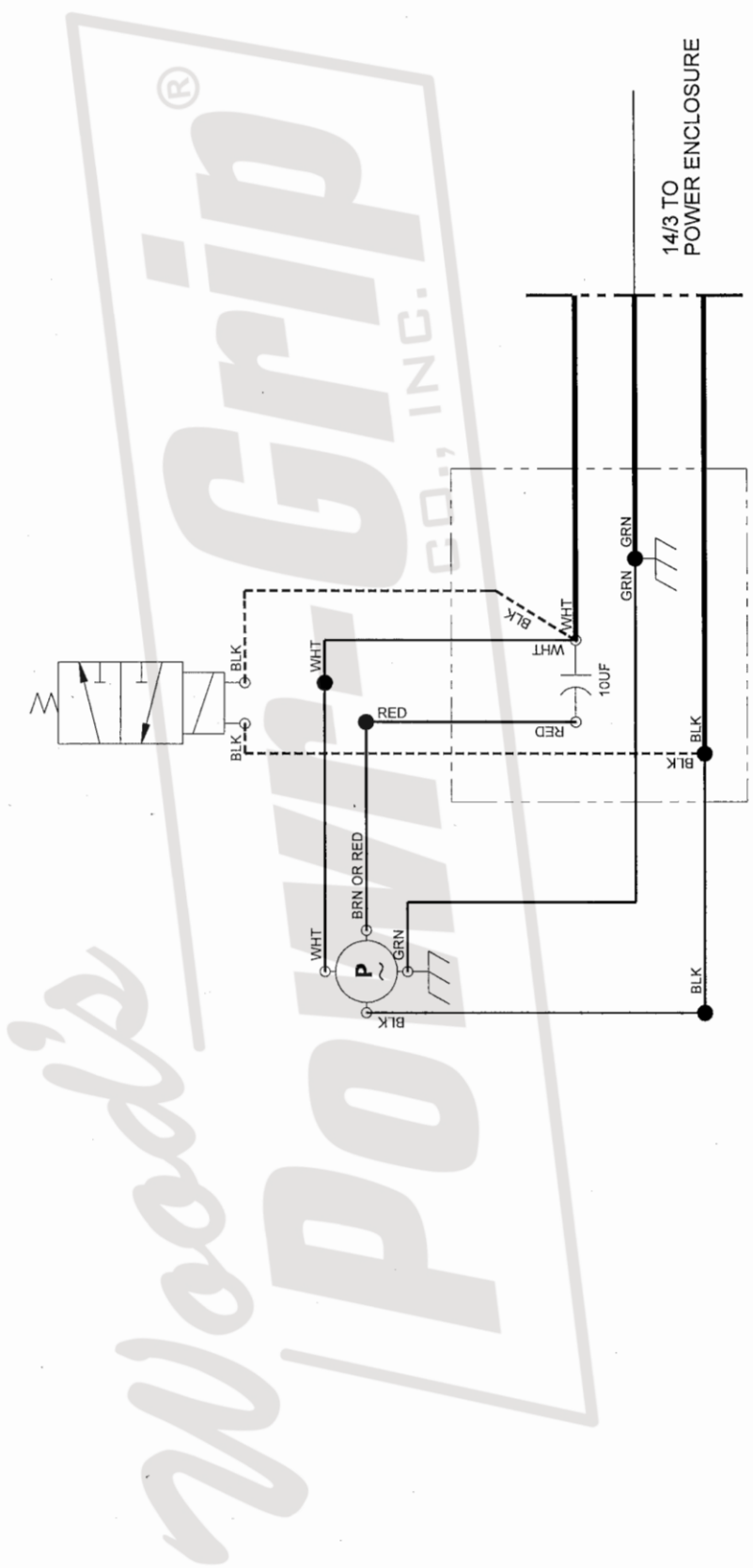

716
716-W01 [A-W01]

FILE DIRECTORY:
FILE [SHEET]:

TYPE:
STANDARD

THIS DRAWING IS THE PROPERTY OF **WOOD'S POWR-GRIP CO., INC.** LAUREL, MONTANA U.S.A.
IT IS LOANED WITH THE UNDERSTANDING THAT NEITHER IT NOR ANY INFORMATION CONTAINED THEREIN WILL BE COPIED, PUBLISHED OR TRANSMITTED TO OTHERS WITHOUT EXPRESS WRITTEN PERMISSION.

WPG
STANDARD FLOW SOLENOID VALVE PACKAGE
POWER TILT
24V AC VALVE ENCLOSURE W/ RELAYS WIRING DIAGRAM
D716-W01 [A-W01]

WIRE LEGEND: CONTROLLED BY WIRING SYMBOLS DRAWING EXCEPT AS NOTED AND BELOW.
LINE STYLES AND WIDTHS FOR WIRE UNLESS NOTED OTHERWISE.
--- N/A ---
--- 20AWG ---
--- 18AWG ---
--- 16AWG ---

PRODUCT MANAGER: DANIEL M.
DATE: 04/19/2002
CHECKED: *AL*
APPROVED: *OMA*

SIZE: SCALE: A NONE
REVISION: 01-A
ECN NUMBER: 3683
ECN DATE: 03/11/2015
ECON BY: SPE
EST. WEIGHT: N/A

NOTES:
1) MAY SUBSTITUTE GRN W/ YS FOR GRN.

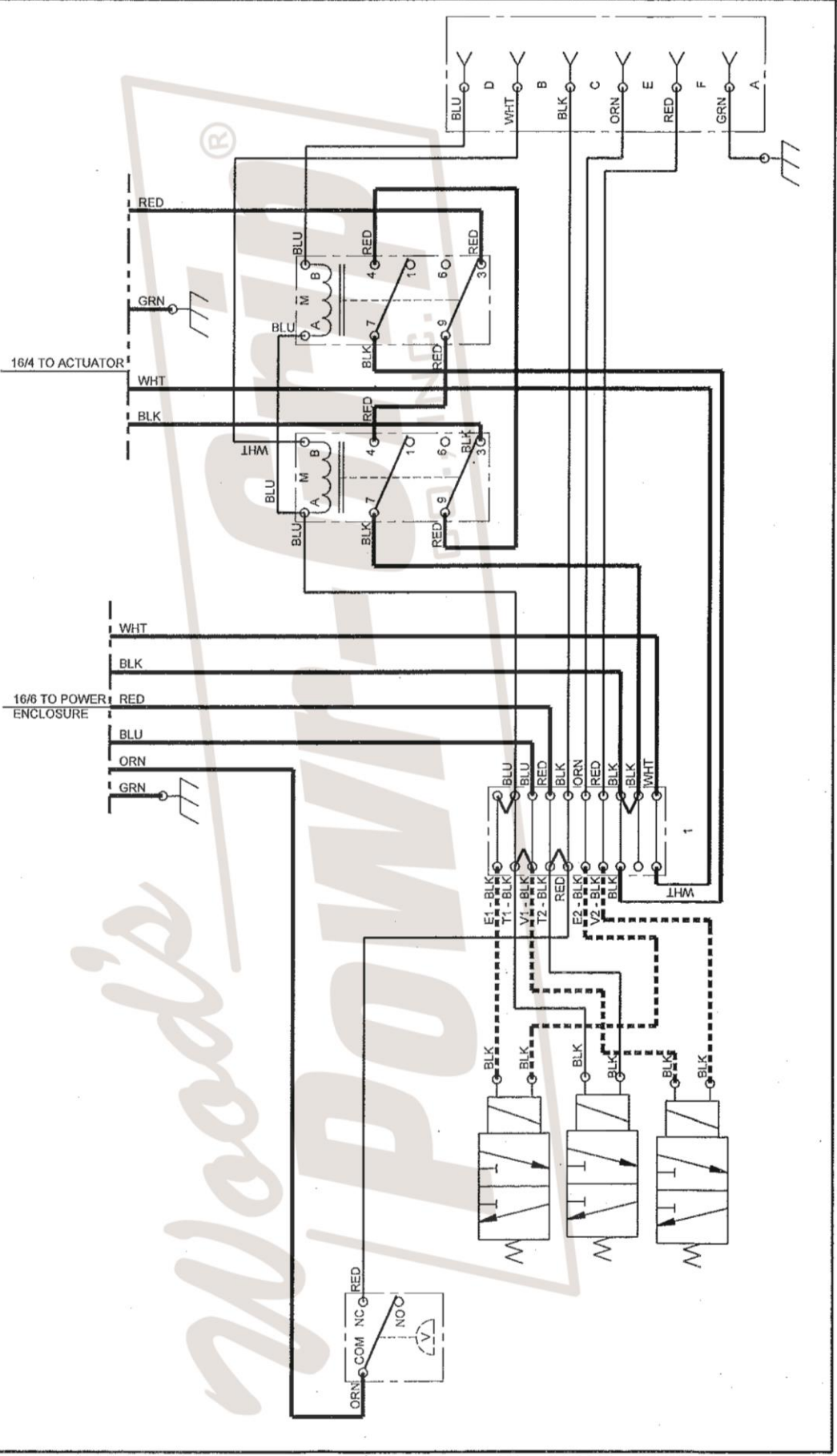

WIRE LEGEND: CONTROLLED BY WIRING SYMBOLS DRAWING EXCEPT AS NOTED AND BELOW.		TYPE: STANDARD	FILE DIRECTORY: 716-716
LINE STYLES AND WIDTHS FOR WIRE UNLESS NOTED OTHERWISE.		FILE (SHEET): 716-W02 [A-W02]	
.....	N/A	THIS DRAWING IS THE PROPERTY OF WOOD'S POWER-GRIP CO., INC. LAUREL, MONTANA U.S.A.	
.....	N/A	STANDARD-FLOW SOLENOID-VALVE PACKAGE	
.....	N/A	POWER-TILT	
.....	N/A	AC 1-ACTION RELEASE W/POWER TILT PENDANT WIRING SCHEM	
.....	N/A	D716-W02 [A-W02]	
PRODUCT MANAGER:	DANIEL M.	DATE: 03/26/2002	REVISION: 02.A
CHECKED:	<i>CR</i>	ECN NUMBER: 4486	ECN DATE: 01/23/2018
APPROVED:	<i>Omni</i>	EST. WEIGHT: N/A	JAC

- NOTES:
- (1) SUBSTITUTE YELLOW WIRE FOR BLUE IF BLUE WIRE IS UNAVAILABLE.
 - (2) SUBSTITUTE BROWN WIRE FOR ORANGE IF ORANGE WIRE IS UNAVAILABLE.

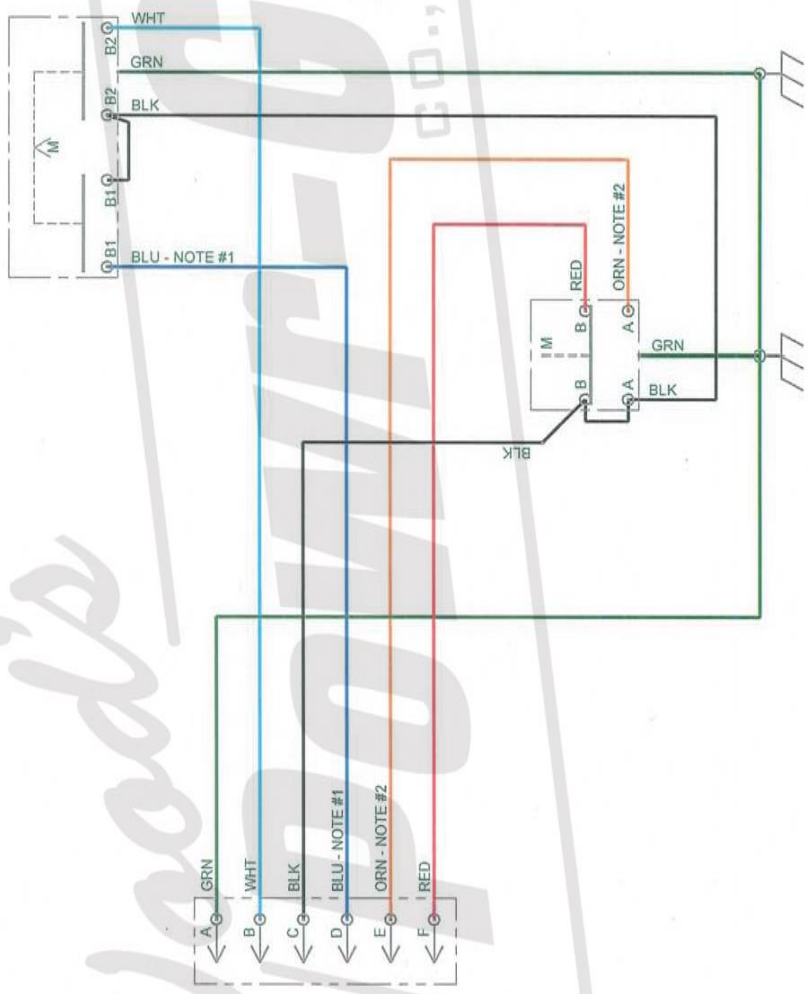

WIRE LEGEND: CONTROLLED BY WIRING SYMBOLS DRAWING EXCEPT AS NOTED AND BELOW.		TYPE: STANDARD		DIRECTORY: FILE (SHEET):	
---		16AWG		H:\Working\STD\716-SOLECN\27721	
---		N/A		716A-W03 [A-W03]	
---		N/A		WOOD'S POWR-GRIP CO., INC.	
---		N/A		LAUREL, MONTANA U.S.A.	
---		N/A		THIS DRAWING IS THE PROPERTY OF WOOD'S POWR-GRIP CO., INC. IT IS LOANED WITH THE UNDERSTANDING THAT NEITHER IT NOR ANY INFORMATION CONTAINED THEREIN WILL BE COPIED, PUBLISHED OR TRANSMITTED TO OTHERS WITHOUT EXPRESS WRITTEN PERMISSION.	
DRAWN: L. RENNER		DATE: 05/29/2007		STANDARD FLOW SOLENOID VALVE PACKAGE	
CHECKED: CR		DATE: 02-27-12		POWER TILT ACTUATOR WIRING DIAGRAM	
APPROVED: <i>Conn.</i>		DATE: 2-28-12		D716A-W03 [A-W03]	
SIZE: A		SCALE: NONE		REV: 1	
ECN NUMBER: 2772		DATE: 12/15/2011		BY: RAS	



TB-R06 7/16

FILE DIRECTORY: 716B-W01 [C-W01]

TYPE: STANDARD

WIRE LEGEND: CONTROLLED BY WIRING SYMBOLS DRAWING EXCEPT AS NOTED AND BELOW.

LINE STYLES AND WIDTHS FOR WIRE UNLESS NOTED OTHERWISE:

.....	N/A	20AWG	N/A	18AWG
----	N/A	16AWG	N/A	14AWG
----	N/A	14AWG	N/A	12AWG

PRODUCT MANAGER: DANIEL M.

DATE: 09/13/2006

CHECKED: CR

APPROVED: *[Signature]*

SIZE: A

SCALE: NONE

REVISION: 03.A

ECN NUMBER: 4263

ECN DATE: 02/06/2017

EST. WEIGHT: N/A

716B-W01 [C-W01]

WOOD'S POWR-GRIP CO., INC. LAUREL, MONTANA U.S.A.

STANDARD-FLOW SOLENOID-VALVE PACKAGE TRANSFORMER ENCLOSURE W/POWER TILT POWER SWITCH ENCLOSURE W/TILT WIRING SCHEMATIC D716B-W01 [C-W01]

