

**KEEP FOR FUTURE REFERENCE**



*P.O. Box 368 – 908 West Main  
Laurel, MT USA 59044  
phone 800-548-7341  
phone 406-628-8231  
fax 406-628-8354*

# INSTRUCTIONS

International Version

MODEL NUMBER: MT1TL6FAIR

SERIAL NUMBER: \_\_\_\_\_  
(please see serial label and record number here)

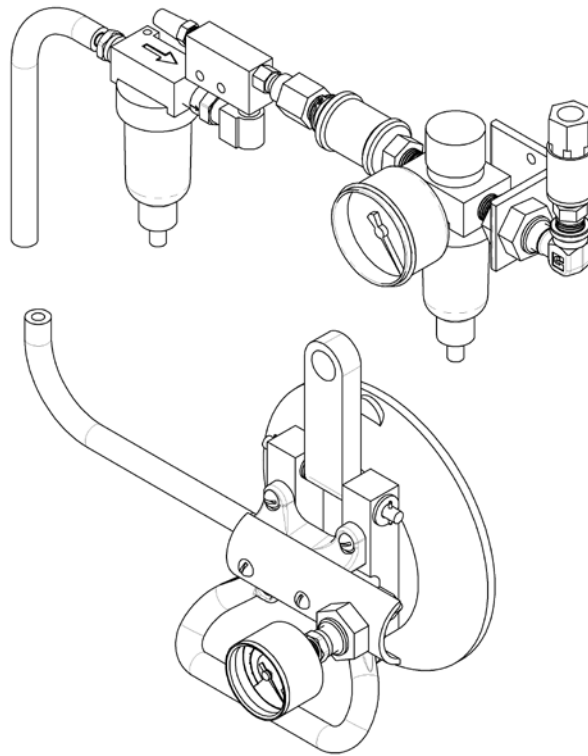

**MANUAL TILTER  
AIR-POWERED**



***READ ALL INSTRUCTIONS AND WARNINGS  
BEFORE OPERATING THIS LIFTER***



**DESIGNED FOR THE MATERIALS HANDLING PROFESSIONAL**



# TABLE OF CONTENTS

---

<b>SPECIFICATIONS</b> .....	<b>3</b>
<b>WARNINGS</b> .....	<b>4</b>
<b>OPERATING FEATURES</b> .....	<b>5</b>
<b>ASSEMBLY</b> .....	<b>6</b>
<b>INTENDED USE</b> .....	<b>7</b>
<b>LOAD CHARACTERISTICS</b> .....	<b>7</b>
<b>OPERATING ENVIRONMENT</b> .....	<b>8</b>
<b>DISPOSAL OF THE LIFTER</b> .....	<b>8</b>
<b>OPERATION</b> .....	<b>9</b>
<b>BEFORE USING THE LIFTER</b> .....	<b>9</b>
Taking Safety Precautions.....	9
Performing Inspections and Tests.....	9
<b>TO APPLY THE PAD TO A LOAD</b> .....	<b>9</b>
Generating Airflow to Create Vacuum .....	9
Positioning the Lifter on the Load .....	10
Reading the Vacuum Gauge.....	10
Vacuum Level on Optimal Surfaces.....	10
Vacuum Level on Other Surfaces.....	10
<b>TO LIFT AND MOVE THE LOAD</b> .....	<b>11</b>
Load Capacity and the Vacuum Gauge.....	11
Monitoring the Vacuum Gauge .....	11
Controlling the Lifter and Load .....	11
In Case of Power Failure.....	11
<b>TO TILT THE LOAD</b> .....	<b>12</b>
<b>TO LAND THE LOAD</b> .....	<b>12</b>
<b>TO RELEASE THE PAD FROM THE LOAD</b> .....	<b>12</b>
Releasing the pad locally .....	12
Releasing the pad remotely .....	12
<b>AFTER USING THE LIFTER</b> .....	<b>12</b>
Storing the Lifter.....	12
<b>MAINTENANCE</b> .....	<b>13</b>
<b>INSPECTION SCHEDULE</b> .....	<b>13</b>
Every-Lift Inspection .....	13
Frequent Inspection .....	13
Periodic Inspection.....	13
Infrequent Use .....	14
<b>TESTING SCHEDULE</b> .....	<b>14</b>
Operational Tests.....	14
Load Test.....	14

**MAINTENANCE SCHEDULE..... 15**  
**VACUUM PAD MAINTENANCE..... 15**  
    Friction Coefficient ..... 15  
    Inspection ..... 15  
    Cleaning..... 16  
**VACUUM TEST ..... 16**  
**AIR FILTER MAINTENANCE – SMALL ..... 17**  
    Filter Function and Conditions Requiring Service ..... 17  
    Filter Service Procedures ..... 17  
**VACUUM PUMP TEST ..... 18**  
**REPLACEMENT PARTS LIST..... 19**  
**LIMITED WARRANTY ..... 20**

# SPECIFICATIONS

---

<b>Model Number:</b>	MT1TL6FAIR
<b>Description:</b>	Designed for use with a crane or other hoisting equipment, the MT1TL6FAIR lifter employs vacuum to hold a load for lifting, and it provides manual 90° tilt movement for load manipulation.
<b>Power Source:</b>	Compressed air, 80-150 psi [550-1035 kPa] line pressure, 2 SCFM [57 liters/minute] @ 80 psi [550 kPa]
<b>Vacuum Pad / Pad Spread:</b>	One 6" [15 cm] nominal diameter, concave (Model TL6F), standard rubber, with #60 filter screen
<b>Maximum Load Capacity:</b>	50 lbs [25 kg] rated at 16" Hg [-54 kPa] on clean, smooth, nonporous flat surfaces <sup>1</sup>
<b>Lifter Weight:</b>	3.25 lbs [1.47 kg]
<b>Vacuum System Weight:</b>	2.15 lbs [0.96 kg]
<b>Tilt Capability:</b>	Manual, 90°
<b>Vacuum Pump:</b>	Venturi type, 1 SCFM [28 liters/minute] nominal airflow @ 80 psi [550 kPa]
<b>Vacuum Reserve:</b>	Vacuum reserve system helps prevent immediate vacuum loss in case of power failure.
<b>Vacuum Gauge:</b>	Dial gauge indicates current vacuum level in positive inches of Hg and negative kPa.
<b>Operating Elevation:</b>	Maximum = 13,000' [3,962 m]
<b>Operating Temperatures:</b>	32° to 120° F [0° to 49° C]
<b>Service Life:</b>	This lifter is designed to have a service life of at least 20,000 lifting cycles, when used and maintained as intended. Vacuum pads, filter elements and other wear-out items are excluded (see MAINTENANCE and REPLACEMENT PARTS LIST for more information). For the DISPOSAL OF THE LIFTER after its service life, see INTENDED USE.
<b>ASME Standard BTH-1:</b>	Design Category "B", Service Class "0" (see <a href="http://www.wpg.com">www.wpg.com</a> for more information)

---

**!!-CE-!!** Note: This symbol appears in the *INSTRUCTIONS* manual only when requirements of a CE Standard are *different* from requirements of other standards that also apply to this vacuum lifter. CE requirements are mandatory in geographical areas where CE Standards apply, but may be optional in other locations.

---

<sup>1</sup> Load Capacity is based on a friction coefficient of 1; see MAINTENANCE: VACUUM PAD MAINTENANCE: Friction Coefficient for additional information.

# WARNINGS

---



Powr-Grip is pleased to offer the most reliable vacuum lifters available. Despite the high degree of security provided by this product, certain precautions must be observed to protect the operator and others.



**Always** wear personal protective equipment that is appropriate for the material being handled. Follow trade association guidelines.

**Always** operate the lifter under conditions approved for its design (see INTENDED USE: OPERATING ENVIRONMENT).

**Never** operate a lifter that is damaged, malfunctioning, or missing parts.

**Never** operate a lifter if the sealing edge of any vacuum pad is cut or otherwise damaged.

**Never** remove or obscure warning labels.

**Never** operate a lifter if the Maximum Load Capacity or any warning appears to be missing or obscured.

**Always** make certain the contact surfaces of the load and all vacuum pads are clean prior to applying the pads (see MAINTENANCE: VACUUM PAD MAINTENANCE).

**Never** exceed the Maximum Load Capacity or attempt to lift loads the lifter is not designed for (see INTENDED USE: LOAD CHARACTERISTICS).

**Never** attempt to lift cracked or broken glass with this lifter.

**Always** position the vacuum pads correctly on the load prior to lifting (see OPERATION: TO APPLY THE PADS TO A LOAD).

**Never** lift a load when any vacuum indicator shows inadequate vacuum.

**Never** touch the vacuum release controls during a lift. This may result in loss of vacuum and release of the load.

**Never** allow people to ride on the lifter or the load being lifted.

**Never** lift a load higher than necessary or leave suspended loads unattended.

**Never** lift a load over people.

**Always** keep other personnel far enough away from the lifter to avoid injury in the event of an unexpected load release.

**Always** place the power control in the inactive position and, when possible, disconnect the power source before opening any enclosure on the lifter. (Only applicable to powered lifters)

**Always** remember that modifications to the lifter may compromise its safety. Wood's Powr-Grip cannot be responsible for the safety of a lifter that has been modified by the customer. For consultation, contact Wood's Powr-Grip (see LIMITED WARRANTY).

# OPERATING FEATURES

Note: Components featured in the following instructions for assembling, operating or maintaining the vacuum lifter are underlined> on their first appearance in each section.

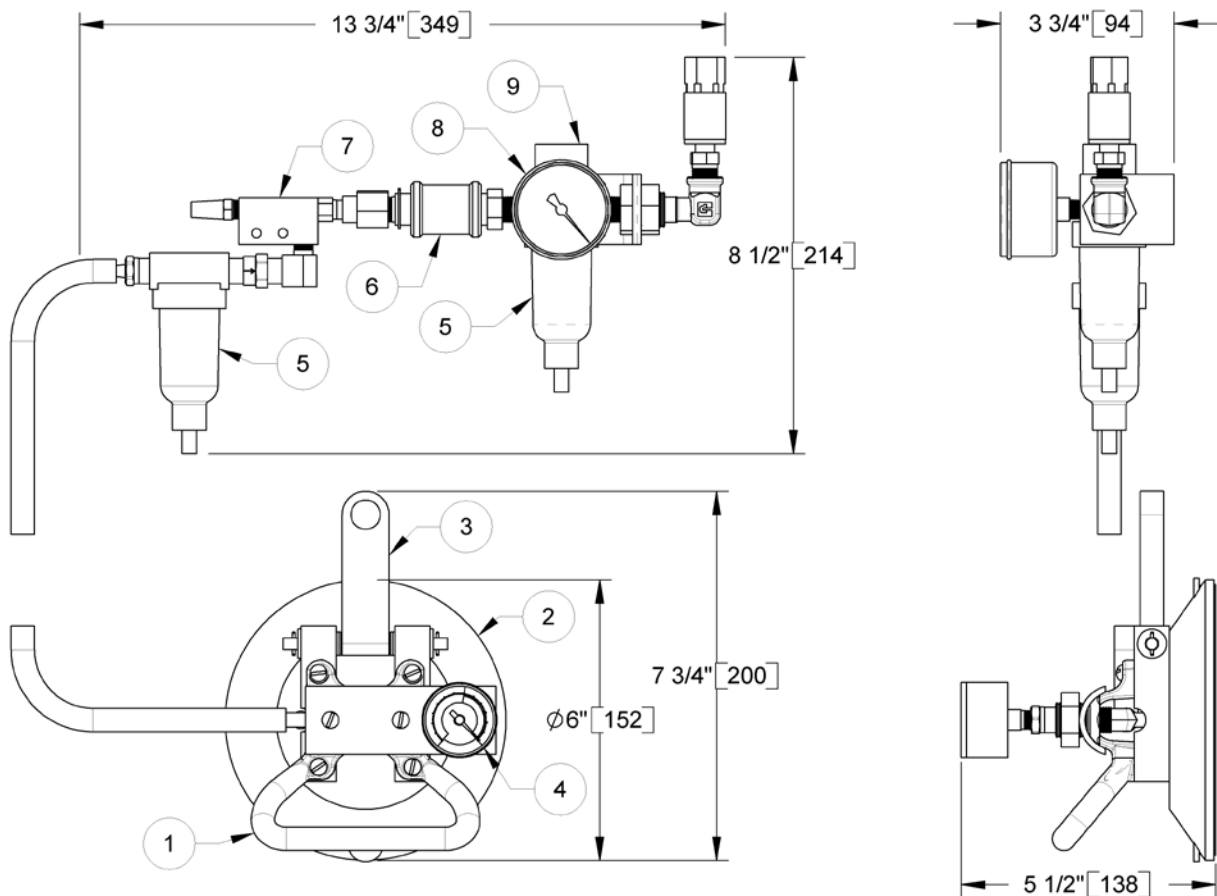

Standard MT1TL6FAIR shown.

- |                  |                          |
|------------------|--------------------------|
| 1 CONTROL HANDLE | 6 VACUUM CONTROL VALVE   |
| 2 VACUUM PAD     | 7 VACUUM PUMP            |
| 3 LIFT BRACKET   | 8 PRESSURE GAUGE         |
| 4 VACUUM GAUGE   | 9 AIR PRESSURE REGULATOR |
| 5 AIR FILTERS    |                          |

# ASSEMBLY

---

- 1) Remove all vacuum lifter restraints. Save the container for transportation use.
- 2) Suspend the lifter from a hoisting system: Select hoisting equipment rated to carry the specified maximum load weight plus the lifter weight.

Note: All lifter use must conform to all statutory or regulatory standards related to the hoisting equipment in its geographical location (eg, relevant OSHA standards in the USA).

 **WARNING: Hoisting equipment hook must be fitted with restraining latch to prevent lift bracket from slipping off under any circumstances.**

Attach the hoisting equipment hook to the eye of the lift bracket. Use a clevis if the eye is too small for the hoisting equipment hook.

Note: Some hoisting equipment hooks could interfere with an upright load that extends beyond the lifter's vacuum pad. If the load would contact the hook, the operator must prevent this by attaching a sling (or other rigging) between the hook and the lift bracket.

 **WARNING: Any clevis, clevis pin or sling used must be rated to carry maximum load weight plus lifter weight.**

Remove the pad cover and save it for use whenever the lifter is stored.

- 3) Mount vacuum generating system in a protected location suitable for operating the lifter and hoisting equipment (mounting hardware not supplied). Route vacuum line so it is not tangled, kinked, pinched or cut during operation. If help, contact WPG or an authorized dealer.

Note: Hoisting equipment design and applicable statutory or regulatory standards must be followed. Consult hoisting equipment manufacturer to determine how to mount the vacuum generating system in a safe location that will not interfere with hoisting equipment operation.

- 4) Connect the lifter to an appropriate compressed air supply (see SPECIFICATIONS):

Install the female quick connector (supplied) on the compressed air line. Connect the female quick connector to the male quick connector mounted adjacent to the air pressure regulator.

Adjust the pressure regulator to supply a minimum air pressure of 80 psi [550 kPa]:<sup>2</sup>

4.1) Place the vacuum control valve in the "on" (☐) position, to engage the compressed air supply. Note: Do **not** apply the lifter to a load while adjusting regulator.

4.2) Pull up the adjustment collar on the top of the regulator, and turn the collar clockwise to increase pressure or counter-clockwise to reduce pressure.

When the pressure gauge registers a minimum air pressure of 80 psi [550 kPa], push down the collar to lock it in place.

Note: Place the vacuum control valve in the "off" (○) position when the lifter is not in use; otherwise, the vacuum pump would continue to consume air, causing the air compressor to cycle frequently.

Route air line so it does not become tangled, kinked, pinched or cut while operating the lifter or hoisting equipment. Now the lifter is operational.

- 5) Perform Operational and Load Tests for the lifter as directed in MAINTENANCE.

---

<sup>2</sup> Exceeding this pressure consumes more air and does not improve lifter performance.



# INTENDED USE

---

## LOAD CHARACTERISTICS

 **WARNING:** *This lifter is NOT intended for lifting hazardous materials, such as explosives or radioactive substances.*

The operator must verify that the lifter is intended to handle each load, in accordance with the following requirements:

- The load must not exceed the maximum allowable weight specified under Load Capacity (see SPECIFICATIONS).
- The load must be a single piece of nonporous or semiporous material with a flat and relatively smooth contact surface.<sup>3</sup> To determine whether the load is too porous or rough, perform the test under Vacuum Level on Other Surfaces (see OPERATION: TO APPLY THE PADS TO A LOAD).
- The load's contact surface must be suitable for obtaining a friction coefficient of 1 with the lifter's vacuum pads (see MAINTENANCE: VACUUM PAD MAINTENANCE: Friction Coefficient), as verified by a friction test, or capacity should be derated appropriately. If necessary, contact Wood's Powr-Grip for help in conducting a friction test.
- In order to avoid damaging the vacuum pads, the load's surface temperature must not exceed the allowable Operating Temperatures (see SPECIFICATIONS). However, if such an application cannot be avoided, Wood's Powr-Grip does offer a heat-resistant rubber compound and other solutions which may enable you to lift loads with higher surface temperatures. Contact Wood's Powr-Grip or an authorized dealer for more information.
- While the *minimum* length and width of the load are determined by the Pad Spread (see SPECIFICATIONS), the *maximum* length and width are determined by the allowable overhang, or the amount of load material that can extend sideways beyond the vacuum pads without breaking or otherwise being damaged.

The allowable overhang depends on the kind of load material being lifted, the thickness of the material, and the angle at which it is handled (if any). Since materials such as glass, stone or sheet metal each have different physical properties, the allowable overhang must be evaluated separately for each type of load. If necessary, contact Wood's Powr-Grip or an authorized dealer for help in determining the recommended overhang in a specific situation.

- Although the thickness of the load is not restricted for this lifter, load thickness may affect the lifter's hang angle and the amount of operator effort required for handling loads.

Note: Vacuum pads can stain or deform load surfaces with light colors or soft coatings. The operator should test such surfaces for detrimental effects before using the lifter on them.

---

<sup>3</sup> Lifters that feature concave vacuum pads can also attach to some kinds of curved loads. Since curvature affects the lifting capacity, contact Wood's Powr-Grip for help in determining the Load Capacity for a particular curved load.

# OPERATING ENVIRONMENT

The operator must determine whether the lifter is intended to be used in each work environment, in accordance with the following restrictions:

 **WARNING: Never use lifter in dangerous environments.**

- This lifter is not intended for use in any environment that is inherently dangerous to the operator or likely to compromise the lifter's ability to function. Environments containing explosives, caustic chemicals and other dangerous substances must be avoided when using the lifter.
- The lifter's work environment is limited by the Operating Elevation and Operating Temperatures indicated in SPECIFICATIONS.
- The lifter's work environment must be free of metal particles or any other contaminants that could damage lifter components through airborne contact or any other means of transmission in the environment. If such contaminants cause a vacuum pump failure, they could result in a load release and possible injury to the operator or others nearby.

 **WARNING: Environmental contaminants could result in vacuum pump failure.**

- Using the lifter in wet environments may require the operator to take special precautions: Moisture on contact surfaces of the load or vacuum pads diminishes the lifter's slip resistance, thereby reducing the lifting capacity (see MAINTENANCE: VACUUM PAD MAINTENANCE: Friction Coefficient).

 **WARNING: Moisture reduces slip resistance of vacuum pads.**

Although the lifter's exterior surfaces can tolerate some exposure to water vapor, they are not designed to be water-tight. Submerging the lifter or using it in rain may damage lifter components; these and similar conditions must be avoided.

- 
- **!!-CE-!!** If the lifter is employed in a construction area, CE Standard EN 13155 requires the use of a secondary positive holding device, such as a sling system, designed to support the load in case of a vacuum system failure.

 **WARNING: Where CE Standards apply, secondary positive holding device is required for lifting loads in construction zones.**

---

# DISPOSAL OF THE LIFTER

After the vacuum lifter has reached the end of its service life, you must dispose of the lifter in compliance with all local codes and regulatory standards that are relevant for the geographical region.

# OPERATION

---

## BEFORE USING THE LIFTER

The operator must determine whether the lifter is capable of performing each intended task, in accordance with the SPECIFICATIONS and INTENDED USE sections of this *INSTRUCTIONS* manual. In addition, all of the following preparations must be completed prior to lifting any load.

### Taking Safety Precautions

The operator must be trained in all relevant industry and regulatory standards for the operation of the vacuum lifter in its geographical location (eg, ASME B30.20 in the USA).

The operator must read and understand this *INSTRUCTIONS* manual, including all **WARNINGS**, before using the lifter. If necessary, contact Wood's Powr-Grip or an authorized dealer for assistance.

 **WARNING: Always wear appropriate personal protective equipment.**

The operator must wear any personal protective equipment and take any other precautions required to handle the load safely. Consult appropriate trade association guidelines to determine what precautions are necessary for each type of load material.

### Performing Inspections and Tests

Perform all inspections and tests required by the INSPECTION and TESTING SCHEDULES (see MAINTENANCE). In addition, if the lifter has been in storage, always conduct a VACUUM TEST before placing it in service (see MAINTENANCE).

**CAUTION: Examine each air filter regularly, and empty when necessary.**

The lifter is equipped with one or more air filters to help protect the vacuum system from contaminants. In order for a filter to function, the operator must empty the filter bowl before enough liquid accumulates to contact any portion of the filter element (see MAINTENANCE: AIR FILTER MAINTENANCE).

## TO APPLY THE PAD TO A LOAD

### Generating Airflow to Create Vacuum

Place the vacuum control valve in the "on" () position. This engages the vacuum pump, causing vacuum to be drawn immediately at the vacuum pad.

 **WARNING: Never place control valve in "off" position while operating lifter; keep pump running throughout lift.**

The lifter is designed for the vacuum pump to run continuously. Any interruption of the airflow during lifter operation could result in the release of the load and possible injury to the operator (see TO LIFT AND MOVE THE LOAD: In Case of Power Failure).

## Positioning the Lifter on the Load

Make certain that the contact surfaces of the load and vacuum pad are free of any contaminants that could prevent the pad from sealing against the load (see MAINTENANCE).

The lifter is designed to automatically carry the load in an upright orientation. Determine which will be the top edge of the load while lifting, and position the vacuum pad near that edge, centering the pad from left to right. This position will maximize stability while lifting the load. Make sure that the vacuum pad will fit entirely on the load's contact surface. Then apply the lifter to the load until the pad seals against the contact surface.

Note: If the vacuum pad has been lying against a hard object (as during shipping), it may be slightly distorted. Although initially it may be difficult to apply the pad to a load, this condition should correct itself with continued use.

## Reading the Vacuum Gauge

The vacuum gauge indicates the current vacuum level in the lifter's vacuum system. The *green* range indicates vacuum levels sufficient for lifting the maximum load weight, whereas the *red* range indicates vacuum levels that are *not* sufficient for lifting the maximum load weight. The gauge needle should show a sudden surge in vacuum as the vacuum pad seals against the load. If it takes more than 5 seconds for the vacuum level to reach 5" Hg [-17 kPa], apply firm pressure at the center of the pad until it seals completely.

## Vacuum Level on Optimal Surfaces

When the lifter is attached to clean, smooth, nonporous load surfaces, it should be able to maintain a vacuum level in the green range on the vacuum gauge, except when used at high elevations (see SPECIFICATIONS: Operating Elevation). If not, perform the VACUUM TEST (see MAINTENANCE) to determine whether there is a deficiency in the vacuum generating system.

## Vacuum Level on Other Surfaces

When the lifter is attached to contaminated, rough or porous load surfaces, it may not be able to maintain a vacuum level in the green range on the vacuum gauge, due to leakage in the seal between the vacuum pad and the load surface. In the case of contamination, thoroughly clean the contact surfaces of the load and the vacuum pad (see MAINTENANCE), and reapply the lifter to the load. If the load has rough or porous surfaces, ***the operator must conduct a test to determine whether the lifter is designed to lift the load:***

- 1) Make sure the lifter's vacuum generating system is functioning correctly (see VACUUM TEST).
- 2) Apply the vacuum pad to the load as previously directed.
- 3) When the vacuum level registers above 16" Hg [-54 kPa] on the vacuum gauge, place the vacuum control valve in the "off" () position.
- 4) Raise the load a minimal distance, to assure that it is supported by the lifter.
- 5) Monitor the vacuum gauge while the load is suspended for 5 minutes: ***The lifter must maintain a minimum vacuum level of 10" Hg [-34 kPa] during this time.*** If not, the load does not possess the characteristics required for using this lifter.<sup>4</sup>

---

<sup>4</sup> Certain load materials are too rough or porous to allow the lifter to form a seal which can be maintained for 5 minutes without power. However, in geographical locations where CE Standards do not apply, it may be possible to use the lifter to lift such loads. Contact Wood's Powr-Grip for more information.

# TO LIFT AND MOVE THE LOAD

## Load Capacity and the Vacuum Gauge

A lifter's Maximum Load Capacity is rated at a vacuum level of 16" Hg [-54 kPa] (see SPECIFICATIONS). Vacuum higher than this level registers in the green range on the vacuum gauge, to indicate that the lifter is ready to lift the maximum load weight.

 **WARNING:** *Never attempt to lift load unless vacuum level registers higher than 16" Hg [-54 kPa].*

Do not attempt to lift the load while vacuum registers lower than 16" Hg [-54 kPa]; such an attempt could result in a load release and possible injury to the operator.

## Monitoring the Vacuum Gauge

 **WARNING:** *Vacuum gauge must be visible to operator throughout entire lift.*

The lifter's vacuum pump runs continuously to maintain sufficient vacuum for lifting the maximum load weight. If the vacuum system experiences leakage while the lifter is attached to the load, the vacuum gauge signals the reduction in vacuum to the operator. Make sure the vacuum gauge shows a vacuum level of 16" Hg [-54 kPa] or higher while you are lifting a load. If not, move away and stay clear of the load until it can be lowered to the ground or a stable support.

 **WARNING:** *Stay clear of any suspended load while vacuum level is lower than 16" Hg [-54 kPa].*

Discontinue lifter use until the cause of the vacuum loss can be determined. If the vacuum level remains lower than 16" Hg [-54 kPa] when the lifter is attached to clean, smooth, nonporous materials, the leakage is likely to be in the vacuum system. In this event, perform the VACUUM TEST (see MAINTENANCE) and inspect the vacuum pad for damage (see MAINTENANCE: VACUUM PAD MAINTENANCE: Inspection). If the vacuum loss cannot be remedied immediately, perform inspection and maintenance as needed to identify and correct any deficiency before resuming normal operation of the lifter.

## Controlling the Lifter and Load

When the vacuum gauge shows that the lifter is ready, use the hoisting equipment to raise the lifter and load as needed to clear any obstacles in their path. A load in the flat position automatically tilts toward the upright position when lifted, due to the lifter's design (see TO TILT THE LOAD to follow). Use the control handle to keep the lifter and load in the desired orientation while they are suspended from the hoisting equipment.

## In Case of Power Failure

 **WARNING:** *Stay clear of any suspended load in the event of a power failure.*

Although the lifter is designed to support the load for at least 5 minutes without power, this depends on many factors, including the condition of the load and the lifter's vacuum system (see INTENDED USE and MAINTENANCE). If a power failure occurs, keep all personnel clear of the suspended load until it can safely be placed on the ground or a stable support. Correct any deficiency before resuming normal operation of the lifter.

## TO TILT THE LOAD

The tilt feature allows operator to lift a load in the upright position and land the load in the flat position, or vice versa. The load requires more vertical space when tilting to the upright position, and more horizontal space when tilting to the flat position. Make sure there is enough clearance for the load to tilt without contact. Tilting to the upright position is automatic, but tilting to the flat position is accomplished with the aid of the hoisting equipment during the landing.

## TO LAND THE LOAD

For a landing in the upright position, simply lower the load onto an appropriate support. For a landing in the flat position, lower the lifter until the bottom edge of the load is supported; then move the lifter forward, allowing the load to tilt while continuing to lower it.

## TO RELEASE THE PAD FROM THE LOAD

**⚠ WARNING: Load must be fully supported before releasing vacuum pad.**

When the load is at rest and fully supported, the vacuum pad can be released either *locally* (from pad location) or *remotely* (from vacuum generating system location).

### Releasing the pad locally

Pull a release tab until the vacuum pad disengages completely from the load. To prevent pad from reattaching to the load, move the lifter away. The lifter can now be applied immediately to another load, otherwise turn off vacuum generating system.

### Releasing the pad remotely

Place the vacuum control valve in the "off" (☐) position until the vacuum pad disengages completely from the load. This turns off the vacuum pump, leaving the lifter ready to repeat the preceding steps, starting with TO APPLY THE PAD TO A LOAD.

## AFTER USING THE LIFTER

Place the vacuum control valve in the "off" (☐) position.

**CAUTION: Do not set lifter against any surfaces which could damage vacuum pads.**

Use the hoisting equipment to gently lower the lifter onto a stable support; then detach the hoisting equipment hook from the lift bracket.

Use original shipping container and secure lifter so vacuum pads are protected during transit.

### Storing the Lifter

Disconnect the compressed air supply, and use the cover supplied to keep the vacuum pad clean.

~~~~~  
**!!-CE-!!** In accordance with CE Standard EN 13155, the lifter is designed to rest on relatively horizontal surfaces without tipping over. To store the lifter in this way, set the lifter with the pad facing downward on a clean, smooth, flat surface.  
~~~~~

# MAINTENANCE

---

 **WARNING:** *Make sure power source is disconnected before servicing lifter.*

Note: One or more hose routing diagrams may be provided in the final section of this *INSTRUCTIONS* manual for reference when servicing the lifter or trouble-shooting a deficiency.

## INSPECTION SCHEDULE

Perform inspections routinely, according to the following frequency schedule:

### Every-Lift Inspection

- Examine the vacuum pads and load surface for contamination or debris (see VACUUM PAD MAINTENANCE to follow).
- Examine the vacuum pads, controls and indicators for visual damage (see VACUUM PAD MAINTENANCE to follow).

If any deficiency is detected during the inspection, correct it before using the lifter and perform the Frequent Inspection to follow.

### Frequent Inspection

*(Following every 20-40 hours' use; or whenever lifter is out of service for 1 month or more)*

- Examine the lifter's structure for visual damage.
- Examine the vacuum system (including vacuum pads, fittings and hoses) for visual damage.
- Examine the air filter for conditions requiring service (see AIR FILTER MAINTENANCE to follow).
- Perform the VACUUM TEST to follow.
- Check for unusual vibrations or noises while operating the lifter.

If any deficiency is detected during the inspection, correct it before using the lifter and perform the Periodic Inspection to follow.

### Periodic Inspection

*(Following every 250-500 hours' use; or whenever lifter is out of service for 1 year or more)*

- Examine the entire lifter for external evidence of looseness, excessive wear, deformation, cracks, excessive corrosion, dents to structural or functional components, cuts, or any deficiency which might constitute a hazard.
- Keep a written record of all Periodic Inspections.

If any deficiency is detected during the inspection, correct it before using the lifter. If necessary, return the lifter to Wood's Powr-Grip or an authorized dealer for repair (see LIMITED WARRANTY).



## Infrequent Use

If a lifter is used less than 1 day in a 2-week period, perform the Periodic Inspection *each time before using the lifter*.

## TESTING SCHEDULE

Perform these tests when placing the lifter in service *initially* and *each time following a repair or modification*. Correct any deficiency and retest before using the lifter.

### Operational Tests

- Perform the VACUUM TEST to follow.
- Test all features and functions of the lifter (see OPERATING FEATURES, OPERATION and MAINTENANCE).

### Load Test

Prove that the lifter can lift 100% of its Maximum Load Capacity (see SPECIFICATIONS), using an actual load or an equivalent simulation.<sup>5</sup> Employ the following method to test with an actual load:

- 1) Place a test load with appropriate LOAD CHARACTERISTICS (see INTENDED USE) on a stable support. Make sure the load is oriented in the upright position.<sup>6</sup>
- 2) Apply the vacuum pads to the load as previously directed.
- 3) When the vacuum level registers above 16" Hg [-54 kPa] on the vacuum gauge, turn off or disconnect the power source (as appropriate).
- 4) Raise the load a minimal distance, to assure that it is supported by the lifter.
- 5) Hold the load for 5 minutes. The load must not slip or fall during this time period. If it does, conduct a VACUUM TEST and inspect each vacuum pad as indicated under VACUUM PAD MAINTENANCE: Inspection (see sections to follow). Correct any deficiency that is found and retest the lifter.

Note: See MAINTENANCE topics to follow for additional directions about inspecting and testing specific lifter components.

---

<sup>5</sup> ASME Standard B30.20 requires the lifter to be tested to 125% of its Load Capacity.

<sup>6</sup> Flat Lifters are exempt from this requirement.



# MAINTENANCE SCHEDULE

Unless specified elsewhere in this *INSTRUCTIONS* manual, the lifter does not require maintenance on a routine basis. Instead, maintenance must be performed whenever a deficiency is indicated by routine inspections or tests. Any maintenance warranted must be performed before resuming normal operation of the lifter.

## VACUUM PAD MAINTENANCE

### Friction Coefficient

The friction coefficient represents the lifter's ability to resist load slippage when the load is oriented in any position except horizontal. If the contact surfaces of either the load or the vacuum pads are not clean, dry and in good condition, slippage is more likely to occur.

The Load Capacity of most Powr-Grip lifters is based on a friction coefficient of 1 (only Flat Lifters are exempt from this requirement). However, a vacuum pad's ability to maintain this friction coefficient is reduced by factors such as contamination, wear, age and exposure to sunlight, as well as the condition of the load's contact surface (see INTENDED USE: LOAD CHARACTERISTICS).

Pads that have surface contamination must be thoroughly cleaned (see Cleaning discussion to follow). Over time, the rubber in a pad may experience hardening or leaching of chemicals, resulting in stiffness or surface glaze. Pads that exhibit wear, stiffness or glaze must be replaced.

In addition, all pads should be replaced on a regular basis, preferably after no more than 2 years, to ensure that the friction coefficient is not compromised. If necessary, contact your dealer or Wood's Powr-Grip for more information.

### Inspection

Inspect each vacuum pad for the following deficiencies routinely, as directed in the preceding INSPECTION and TESTING SCHEDULES. Correct any deficiency before using the lifter.

- Contaminates on the pad face or sealing edges: Soil build-up can prevent pads from sealing adequately or reduce the friction coefficient (see discussion preceding). Follow the directions to clean pads as necessary (see discussion to follow).
- Filter screen missing from pad face: This screen helps prevent debris from plugging the vacuum hose and the air filter. Replace any missing screen immediately (see REPLACEMENT PARTS LIST).
- Nicks, cuts or abrasions in sealing edges: Pad damage can reduce the lifting capacity of the lifter. Replace any damaged pad immediately (see REPLACEMENT PARTS LIST).<sup>7</sup>

 **WARNING: Replace vacuum pad if sealing edge has any nicks, cuts or abrasions.**

- Wear, stiffness or glaze: See Friction Coefficient preceding. Replace any pad that exhibits wear, stiffness or glaze (see REPLACEMENT PARTS LIST).

---

<sup>7</sup> If the lifter is equipped with VPFS10T or VPFS625 pads, the sealing edge is the replaceable sealing ring. When it is damaged, see TO REPLACE SEALING RING INSERT IN VACUUM PAD to follow.

## Cleaning

Regularly clean the face of each vacuum pad to remove oil, dust and any other contaminants. Acceptable cleaning agents include soapy water and other mild cleansers. Do *not* use solvents, petroleum-based products (including kerosene, gasoline and diesel fuel) or any harsh chemicals for cleaning. Do *not* use unauthorized rubber cleaners or conditioners, such as those intended for cleaning tires or vinyl surfaces, because those products can leave a hazardous film on vacuum pads which significantly reduces their lifting capacity (see Friction Coefficient preceding). The use of any unauthorized cleaning agent is prohibited because it could damage the pad and/or create a hazard to the operator or others.

 **WARNING: Never use solvents, gasoline or other harsh chemicals to clean vacuum pad.**

 **WARNING: Never use unauthorized rubber cleaners or conditioners to clean vacuum pad.**

To prevent liquid from contaminating the vacuum system during cleaning, cover the suction hole in the recess for the filter screen or make sure the pad faces downward. Use a clean sponge or lint-free cloth to apply an authorized cleanser and wipe the pad face clean. A toothbrush (or similar brush with bristles *that do not harm rubber*) may be used to remove contaminants clinging to sealing edges.<sup>8</sup> Wipe all residue from the pad face, and allow the pad to dry completely before using the lifter.

## VACUUM TEST

Test the vacuum system for leakage routinely, as directed in the preceding INSPECTION and TESTING SCHEDULES.

- 1) Clean the face of each vacuum pad as previously directed (see VACUUM PAD MAINTENANCE: Cleaning).
- 2) Apply the lifter to a clean, smooth, nonporous surface. The surface should be flat or possess no more curvature than the lifter is designed for (if any).<sup>9</sup>
- 3) When the vacuum level registers above 16" Hg [-54 kPa] on the vacuum gauge, turn off or disconnect the power source (as appropriate) and leave the pads attached to the surface.
- 4) Monitor the vacuum gauge: *The vacuum level should not decrease by more than 4" Hg [-14 kPa] in 10 minutes.*

 **WARNING: If lifter fails vacuum test, discontinue use immediately.**

Correct any deficiency in the vacuum system before using the lifter (see relevant Leak Test Procedures at [www.WPG.com](http://www.WPG.com) or contact Wood's Powr-Grip for assistance). If no leakage is detected in the vacuum system, conduct the VACUUM PUMP TEST to follow.

---

<sup>8</sup> If these cleaning methods are not successful, contact Wood's Powr-Grip or an authorized dealer for assistance.

<sup>9</sup> Any test material used must be fully and independently supported, and capable of bearing the lifter's weight. Do not use the lifter to lift the test material during the vacuum test.

# AIR FILTER MAINTENANCE – SMALL

(For 1 oz [30 ml] bowl size filters)

## Filter Function and Conditions Requiring Service

An air filter prevents solid particles and liquid from contaminating components in the vacuum system.

**CAUTION:** *Examine air filter regularly and empty when necessary.*

Liquid must not contact any portion of the filter element; remove trapped liquid regularly. Replace the element if it has an overall dirty appearance, or if there is a noticeable increase in the time required to attain full vacuum. (Refer to REPLACEMENT PARTS LIST for filter element kit.)

## Filter Service Procedures

- 1) Unscrew the bowl (6) from the body (1). Support the body while twisting the bowl, to protect the vacuum line fittings from being damaged.
- 2) Determine whether the filter element (4) needs to be replaced (see Conditions Requiring Service preceding). *If so*, proceed to step 3.  
*If not*, remove any liquid or contaminants from the bowl; clean the old bowl seal (2) with mild soap and water; and skip to step 7.
- 3) Unscrew the element holder (5) and remove all internal parts.
- 4) Set aside the element, element gaskets (7) and bowl seal for disposal later.
- 5) Clean all other internal parts and the bowl, using mild soap and water only. *Do not* use any other cleansing agents.
- 6) Place the new element gaskets and element, along with the old deflector (3), on the element holder, and screw the assembly back into the filter body (tighten gently, finger tight).
- 7) Lubricate the new or cleaned bowl seal (2)<sup>10</sup>, using a mineral base oil or grease (such as the lubricant furnished in the filter element kit). *Do not* use synthetic oils, such as esters, and *do not* use silicones.
- 8) Place the bowl seal around the rim of the bowl. Then screw the bowl back into the body, taking care to avoid contaminating the filter element with lubricant. Hand-tighten only.
- 9) Test the vacuum system to be certain the air filter does not leak (see VACUUM TEST preceding, if applicable).

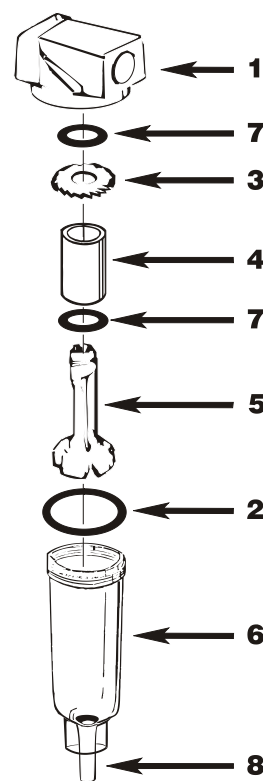

**⚠ WARNING:** When the air filter is being used on a *vacuum* system, rather than with pressure, using the twist drain (8) to remove liquid from the bowl is *not* recommended. *Never* disturb the twist drain, as contaminants could lodge in the drain seal and cause a vacuum leak.

<sup>10</sup> The filter element kit may contain two sizes of bowl seals (O-ring type gaskets). If so, use the smaller bowl seal; or if in doubt, compare the old bowl seal to determine the appropriate size.

## VACUUM PUMP TEST

The venturi-type vacuum pump can wear out over time, as a result of particle abrasion. If the lifter is unable to attain a minimum vacuum level of 16" Hg [-54 kPa] (see VACUUM TEST preceding), evaluate the pump:

- 1) Systematically test all other components in the vacuum generating system for leakage (see relevant Leak Test Procedures at [www.WPG.com](http://www.WPG.com) or contact Wood's Powr-Grip for assistance). Continue only when leakage has been eliminated as the cause of insufficient vacuum.
- 2) Make sure the Power Source consistently supplies compressed air to meet both pressure and volume requirements as stated in SPECIFICATIONS.
- 3) Connect the compressed air supply and adjust the air pressure regulator as directed in ASSEMBLY. Make sure the minimum air pressure requirement is maintained at the lifter.
- 4) If the pump is equipped with a muffler, remove it and perform the VACUUM TEST. **Caution: Hearing protection is recommended when the muffler is removed.** If the lifter is now able to attain a minimum vacuum level of 16" Hg [-54 kPa], replace the muffler (see REPLACEMENT PARTS LIST). If not, proceed to step 5.  
If the pump is **not** equipped with a muffler, proceed to step 5.
- 5) Perform the VACUUM TEST. If the lifter is unable to attain a minimum vacuum level of 16" Hg [-54 kPa], replace the venturi-type vacuum pump (see REPLACEMENT PARTS LIST).

# REPLACEMENT PARTS LIST

---

<b>Stock No.</b>	<b>Description</b>	<b>Qty.</b>
66162	Vacuum Pump – Venturi-Type	1
65440	Vacuum Hose – 1/4" ID (approx. 120" in length)	1
65436	Pressure Hose – 1/4" ID (approx. 360" in length)	1
65289	Vacuum Control Valve	1
65212	Check Valve – 1/4 NPT	1
53128	Hose Fitting – Tee – 5/32" ID	1
49405T	Vacuum Pad – Model TL6F / 6" [15 cm] Diameter – Concave	1
29312	Pad Cover – 6" [15 cm] Diameter	1
16100AM	Muffler – 85db	1
16134	Filter Element Kit (for 1 oz bowl size air filter)	2
16042	Quick Connector – Male	1
16040	Quick Connector – Female	1
15972	Pressure Gauge – 2" Diameter – 1/8 NPT – CBM Type	1
15930	Vacuum Gauge – 2" Diameter – 1/4 NPT – LM Type	1
15632	Pad Filter Screen – Small	1

***SERVICE ONLY WITH IDENTICAL REPLACEMENT PARTS,  
AVAILABLE AT WPG.COM OR THROUGH AN AUTHORIZED WPG DEALER***

# LIMITED WARRANTY

---

Powr-Grip products are carefully constructed, thoroughly inspected at various stages of production, and individually tested. They are warranted to be free from defects in workmanship and materials for a period of one year from the date of purchase.

If a problem develops during the warranty period, follow the instructions hereafter to obtain warranty service. If inspection shows that the problem is due to defective workmanship or materials, Powr-Grip will repair the product without charge.

## ***WARRANTY DOES NOT APPLY WHEN:***

Modifications have been made to the product after leaving the factory.

Rubber portions have been cut or scratched during use.

Repairs are required due to abnormal wear and tear.

The product has been damaged, misused, or neglected.

If a problem is not covered under warranty, Powr-Grip will notify the customer of costs prior to repair. If the customer agrees to pay all repair costs and to receive the repaired product on a C.O.D. basis, Powr-Grip then will proceed with repairs.

## **TO OBTAIN REPAIRS OR WARRANTY SERVICE**

For purchases in *North America*:

Contact the Technical Service Department at Wood's Powr-Grip Co. When factory service is required, ship the complete product—prepaid—along with your name, address and phone number to the street address hereafter.

For purchases in *all other localities*:

Contact your dealer or the Technical Service Department at Wood's Powr-Grip Co. for assistance.

Wood's Powr-Grip Co., Inc.  
908 West Main St. / P.O. Box 368  
Laurel, MT USA 59044

phone 800-548-7341

phone 406-628-8231

fax 406-628-8354