

# WOOD'S POWR-GRIP® CUSTOM DC-POWERED COUNTERBALANCE LIFTER WITH REMOTE CONTROL

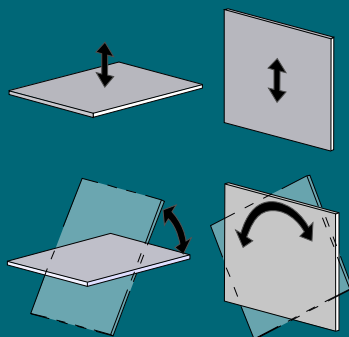

**CB2DCS**  
1600 lbs [725 kg]



(when used with Wood's Powr-Grip's P1-DC, P2-DC & MRTALP Series vacuum lifters)

The CB2DCS Counterbalance Lifter is for use with a crane (or other hoisting equipment) to lift and position windows under gables, overhangs and similar obstructions, by extending the load away from lift slings. This lifter's unique design features a DC-powered counterbalance, which moves on demand along a rugged I-beam to keep the lifter balanced, whether loaded or unloaded.

<b>Maximum Load Capacity</b>	<b>1400 lbs [635 kg]</b> (Including weight of optional vacuum lifter)
<b>Reach</b>	Minimum: 55" [140 cm] Maximum: 69" [175 cm]
<b>Overall Length</b>	154½" [393 cm] (Does not include load or optional vacuum lifter)
<b>Lifter Weight</b>	1040 lbs [472 kg] (Does not include user-supplied ballast material)
<b>Standard Operating Power</b>	12 volts DC, 58 amps
<b>Available Options</b>	Available for lease

## Features

- **DC-Powered Counterbalance** provides effortless counterweight motion, enabling the operator to keep the lifter balanced at all times.
- **Radio Remote Control** enables the operator to control the counterbalance from distances up to 250 ft [76 m] away, as required for window installations in multi-story structures. Note: When paired with remote controlled Powr-Grip vacuum lifters, also syncs with apply and release controls.
- **Fixed & Universal Hook Mounts** provide customized, stable attachment of specific Powr-Grip vacuum lifters, plus the flexibility to attach virtually any kind of vacuum lifter or end effector.
- **Battery Gauge** with segmented LED's allows the operator to visually assess the current energy level of the battery and instantly determine whether charging is needed.
- **Amber Strobe Light** signals to area personnel that a counterweight adjustment is imminent, in case a reaction is required. Note: When paired with remote controlled Powr-Grip vacuum lifters, also warns that load release is imminent.
- **White Indicator Light** signals when counterweight has reached the forwardmost position, enabling the operator to release the load remotely with minimal lifter movement.



**THE ORIGINAL  
& TRUSTED NAME  
IN VACUUM LIFTING  
EQUIPMENT**

**800.548.7341**  
**WPG.com**

908 West Main - P.O. Box 368  
Laurel, Montana 59044 U.S.A.  
406.628.8231 (phone)  
406.628.8354 (fax)

Wood's Powr-Grip products are sold through authorized dealers.

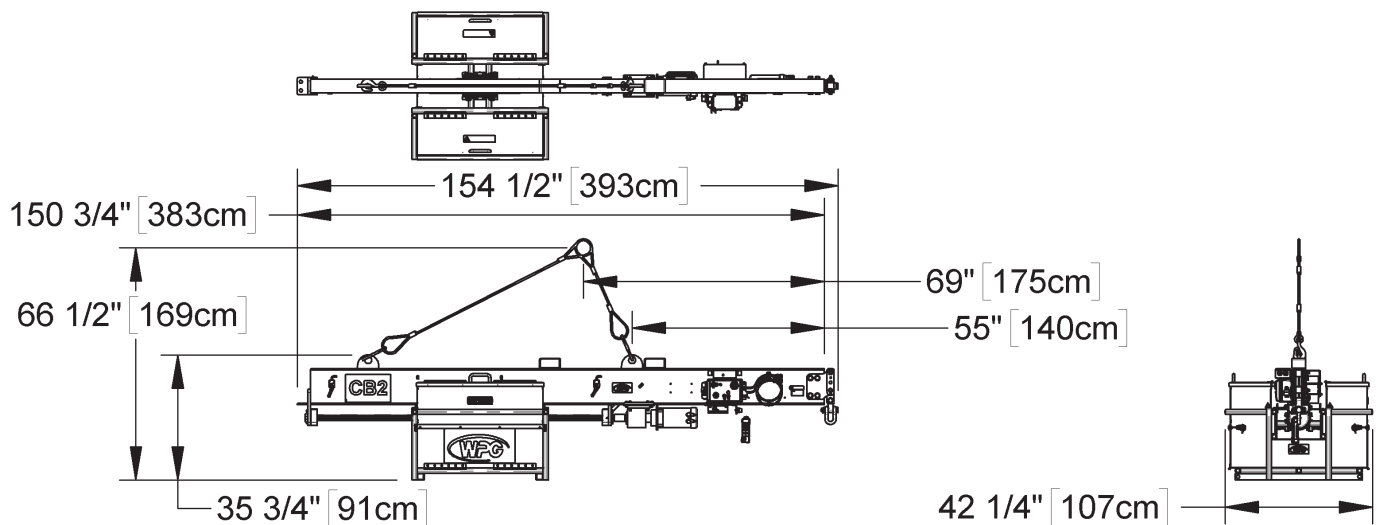

The Counterbalance Lifter comes with radio remote controls, to adjust the counterweight position during multi-story window installations, as well as on-board controls for use on the ground or in a man lift. A specialized fixed mount enables the CB2DCS to be used in conjunction with Powr-Grip's P1-DC, P2-DC and MRTALP Series vacuum lifters, while a universal hook mount accommodates all other kinds of vacuum lifters and end effectors. Powr-Grip's Channel Lifters can also be inverted on the Counterbalance Lifter for reverse-angle installations, such as those in airport control towers. In short, the CB2DCS Counterbalance Lifter represents a dramatic improvement in safety, versatility and functionality over other available designs.

## VACUUM LIFTERS

<b>Standard Pad Spread</b>	P11004DC: 49" x 10" [125 x 25 cm] P11104DC3: 51" x 12" [130 x 30 cm] P2110445DC3: 51" x 54¼" [130 x 138 cm] P211047DC3: 51" x 84¼" [130 x 214 cm] MRTALP811LDC3: 52¾" x 92½" [134 x 235 cm] MRTALPCH611LDC: 79¼" x 12" [201 x 31 cm]
<b>Maximum Load Capacity</b>	P11004DC: 600 lbs [270 kg] P11104DC3: 700 lbs [320 kg] P2110445DC3: 1400 lbs [635 kg] P211047DC3: 1400 lbs [635 kg] MRTALP811LDC3: 1100 lbs [500 kg] MRTALPCH611LDC: 1100 lbs [500 kg]
<b>Specification Sheets</b>	P11004DC: 4-1 P11104DC3: 4-6 P2110445DC3: 4-2 P211047DC3: 4-2 MRTALP811LDC3: 8-10 MRTALPCH611LDC: 8-9