

INTENDED FOR USE BY PROFESSIONAL EQUIPMENT OPERATORS

# OPERATING INSTRUCTIONS



908 W. Main • P.O. Box 368  
Laurel, MT USA 59044  
(1) 800-548-7341  
(1) 406-628-8231  
[www.wpg.com](http://www.wpg.com)

 **READ AND UNDERSTAND BEFORE  
OPERATING THIS EQUIPMENT**



## POWER FILTER, AC-VOLTAGE

Model numbers: PT49AC (shown), PT410TACO

Original Instructions © Wood's Powr-Grip Co., Inc.







# TABLE OF CONTENTS

<b>SPECIFICATIONS</b> .....	<b>3</b>
<b>SAFETY</b> .....	<b>5</b>
<b>OPERATING FEATURES</b> .....	<b>6</b>
<b>ASSEMBLY</b> .....	<b>7</b>
<b>INTENDED USE</b> .....	<b>9</b>
LOAD CHARACTERISTICS.....	9
INDIRECT LOADING .....	10
OPERATING ENVIRONMENT .....	10
DISPOSAL OF THE LIFTER .....	10
<b>OPERATION</b> .....	<b>11</b>
BEFORE USING THE LIFTER.....	11
Taking Safety Precautions .....	11
Performing Inspections and Tests .....	11
Moving the Control Pendant.....	12
TO USE OPTIONAL PAD SHUTOFFS .....	13
TO ATTACH THE PADS TO A LOAD .....	14
Generating Airflow.....	14
Positioning the Lifter on the Load.....	14
Reading the Vacuum Gauge.....	15
TO LIFT AND MOVE THE LOAD.....	16
Interpreting the Lift Light.....	16
Monitoring Vacuum Indicators .....	16
Controlling the Lifter and Load .....	17
In Case of a Power Failure.....	17
TO TILT THE LOAD .....	18
TO RELEASE THE PADS FROM THE LOAD .....	19
AFTER USING THE LIFTER.....	19
Storing the Lifter .....	20
Transporting the Lifter .....	20
<b>INSPECTIONS AND TESTS</b> .....	<b>21</b>
INSPECTION SCHEDULE .....	21
TESTING .....	22

# TABLE OF CONTENTS

Lifter/Load Compatibility Test.....	22
Operational Tests .....	23
Vacuum Test.....	23
Rated Load Test.....	24
<b>MAINTENANCE .....</b>	<b>25</b>
<b>VACUUM PAD MAINTENANCE.....</b>	<b>25</b>
Pad-to-Load Friction Coefficient .....	25
Pad Inspection .....	25
Pad Cleaning .....	26
<b>TO REPLACE SEALING RING IN VPFS10T PADS .....</b>	<b>27</b>
<b>REPLACEMENT PARTS.....</b>	<b>28</b>
<b>REGISTRATION AND LIMITED WARRANTY .....</b>	<b>29</b>
<b>TO REGISTER THIS WPG PRODUCT .....</b>	<b>29</b>
<b>ABOUT THE LIMITED WARRANTY .....</b>	<b>29</b>
Obtaining Warranty Service or Repair Service.....	29

# SPECIFICATIONS

<b>Product Description</b>	Designed for use with hoisting equipment, PT4-AC lifters support loads using vacuum and manipulate loads using powered 90° tilt motion.	
<b>Model Number</b>	PT49AC	PT410TACO
<b>Vacuum Pads<sup>1</sup></b> <i>(standard rubber)</i>	Four 9" [23 cm] nominal diameter (Model VPFS9)	Four 10" [23 cm] nominal diameter, w/ring (Model VPFS10T <sup>2</sup> )
<b>Pad Spread</b> <i>(to outer edges)</i>	20½" x 37½" [52 cm x 96 cm]	Minimum: 19¾" x 53¾" [50 cm x 136 cm] Maximum: 19¾" x 84½" [50 cm x 214 cm]
 <b>Maximum Load Capacity<sup>3</sup></b>	Per pad: 125 lbs [56.5 kg] Total: 500 lbs [225 kg]	Per pad: 150 lbs [68 kg] Total: 600 lbs [270 kg]
 <b>Lifter Weight</b>	165 lbs [75 kg]	
<b>Power Source</b>	See serial label for specific AC voltage, frequency and amperage.	
 <b>Tilt Capability</b>	Powered, 90°; Speed = approx. 6.5 seconds; Duty = 81 tilts per hour	
<b>Product Options</b>	<i>Available</i> with Individual Pad Shutoffs. See separate instructions about other options.	
 <b>Operating Elevation</b>	Up to 6,000' [1,828 m]	
 <b>Operating Temperatures</b>	32° — 104° F [0° — 40° C]	
<b>Service Life</b>	20,000 lifting cycles, when used and maintained as intended. <sup>4</sup>	
<b>ASME Standard BTH-1</b>	Design Category "B", Service Class "0"	
<b>Troubleshooting Guide</b>	<a href="#">TST-016_GENERIC_LEAK_TEST_rev_2014-086</a>	





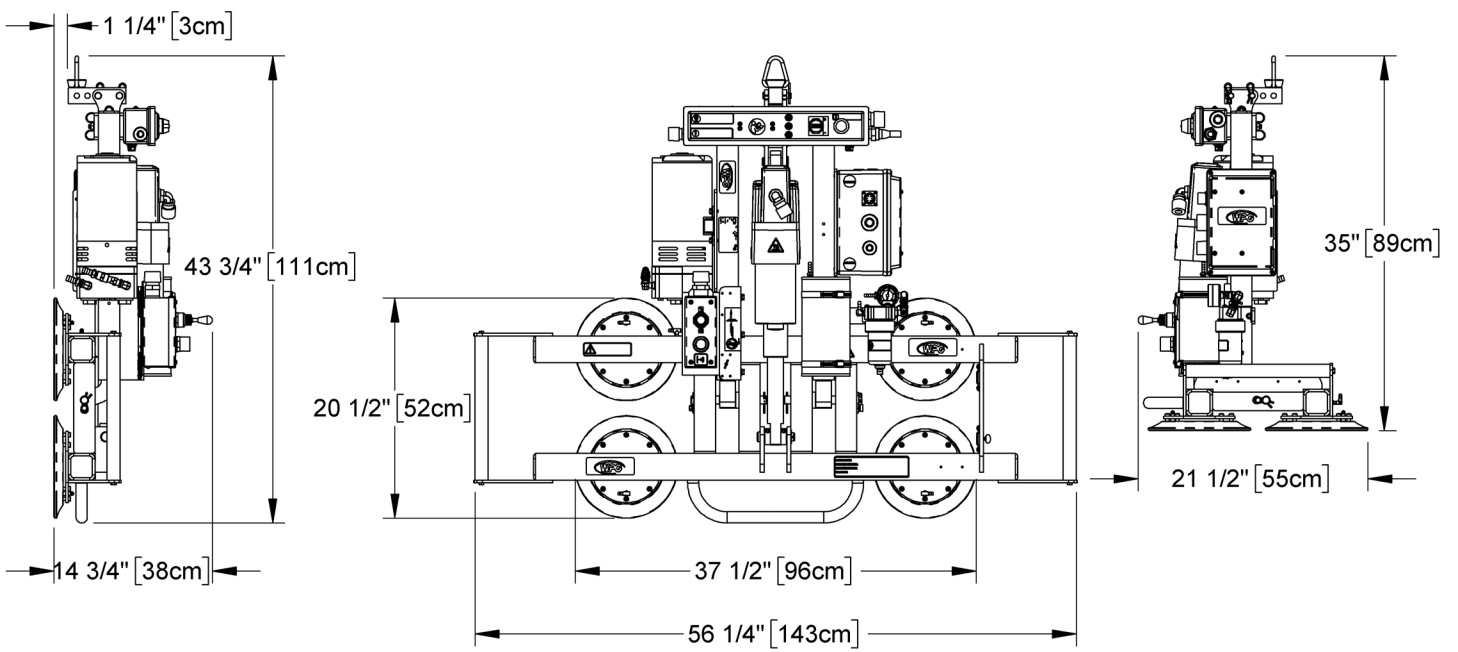















- 1..... Available with [other rubber compounds](#) for special purposes.
- 2..... Standard with replaceable sealing rings for rough or textured surfaces (see ["REPLACEMENT PARTS"](#)).
- 3..... The Maximum Load Capacity is rated at a vacuum of 16" Hg [-54 kPa] on clean, smooth, nonporous flat surfaces with a friction coefficient of 1. Pad compound, load rigidity, strength, surface conditions, overhang, angle, center of gravity and temperature can also affect the lifting capacity. A "qualified person" should evaluate the effective lifting capacity for each use (see definition under ["Rated Load Test"](#)).
- 4..... Vacuum pads, filter elements and other wear-out items are excluded.

# SPECIFICATIONS



*Note: A standard PT49AC is shown.*

# SAFETY

-  Wear personal protective equipment that is appropriate for the load material. Follow trade association guidelines.
-  Do not remove or obscure safety labels.
-  Do not make any modifications to the lifter (see “LIMITED WARRANTY”).
-  Use the lifter only in an approved “OPERATING ENVIRONMENT” (see “INTENDED USE”).
-  Make sure to consider all possible effects of “INDIRECT LOADING” on lifting capacity (see “INTENDED USE”).
-  Do not use a lifter that is damaged, malfunctioning, or missing parts.
-  Do not use a lifter if the sealing edge of any vacuum pad is cut or otherwise damaged.
-  Do not use a lifter to lift cracked or broken glass.
-   Do not exceed the Maximum Load Capacity or lift loads the lifter is not designed for (see “INTENDED USE”).
-   Do not use a lifter if the Maximum Load Capacity or any safety label appears to be missing or obscured.
-  Make sure the contact surfaces of the load and vacuum pads are clean before attaching the lifter (see “MAINTENANCE”).
-  Position the vacuum pads correctly on the load before lifting (see “OPERATION”).
-  Do not lift a load if any vacuum indicator shows inadequate vacuum.
-  Keep unauthorized personnel away from the lifter, to avoid injury in case of an unintended load release.
-  Do not touch the vacuum release controls during a lift.
-  Do not allow people to ride on the lifter or the load.
-  Do not lift a load higher than necessary or leave suspended loads unattended.
-  Do not position a loaded or unloaded lifter over people.
-  Before servicing a powered lifter, place the power control in the inactive position and, when possible, disconnect the power source.

# OPERATING FEATURES

Features shown here are underlined> on their first appearance in each section following.

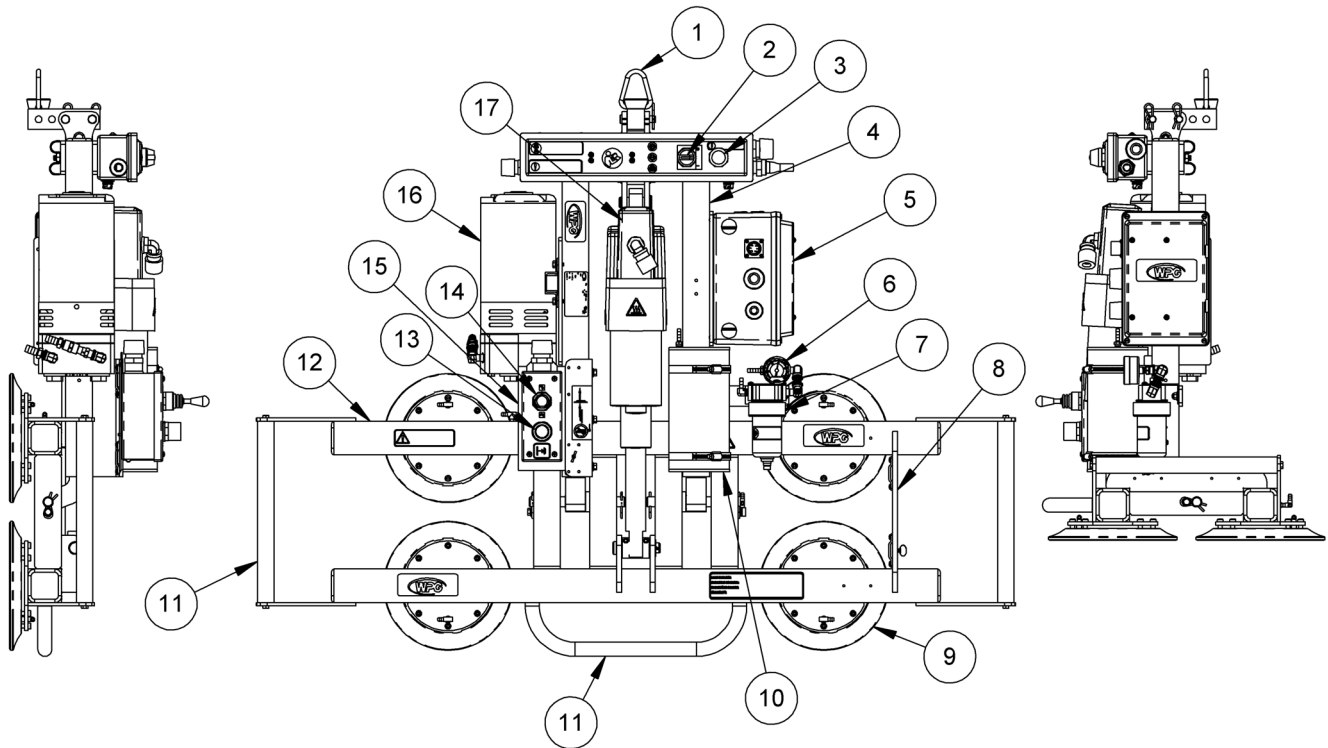

- |    |                       |    |                                     |    |                         |
|----|-----------------------|----|-------------------------------------|----|-------------------------|
| 1  | LIFT POINT            | 2  | POWER SWITCH                        | 3  | VACUUM LIFT LIGHT       |
| 4  | LIFT BAR              | 5  | ENCLOSURE w/ VACUUM SWITCH          | 6  | VACUUM GAUGE            |
| 7  | AIR FILTER            | 8  | PENDANT HOLDER (alternate location) | 9  | VACUUM PAD              |
| 10 | VACUUM RESERVE TANK   | 11 | CONTROL HANDLES                     | 12 | PAD FRAME               |
| 13 | VACUUM RELEASE BUTTON | 14 | TILT TOGGLE SWITCH                  | 15 | MOVABLE CONTROL PENDANT |
| 16 | VACUUM PUMP           | 17 | TILT ACTUATOR                       |    |                         |

*Note: A standard PT49AC is shown. Although some of the following photos do not show this specific lifter, they all illustrate how this kind of lifter functions.*

For information about specific parts, see [“REPLACEMENT PARTS”](#) and/or any separate instructions for Product Options.



# ASSEMBLY

- 1) Remove all shipping materials and save them with the shipping container for future use.
- 2) Adjust the lift point (fig. 2A) to optimize the lifter's hang angle:

- 2.1) Remove each hairpin. Then remove both lift shackle pins.
- 2.2) Move the lift shackle to the appropriate position.<sup>1</sup>
- 2.3) Reinstall both lift shackle pins. Then reinsert the hairpins to secure.



- 3) Connect the power cable:



**Make sure power source has ground fault circuit interrupter.**

- 3.1) Wire the female connector provided to an appropriate power source, as indicated on the label attached.



**Wiring must be performed by qualified service personnel, taking all appropriate safety precautions.**

*Note: Brown-outs, over-taxed generators, extension cords and other conditions can reduce power at the lifter.*



**Without adequate power, lifter could release load, resulting in load damage and personal injury.**

- 3.2) Route the power cable so that it does not become damaged during operation.
- 3.3) Insert the power cable's male connector into the female connector and twist to secure them together (fig. 3A-B).

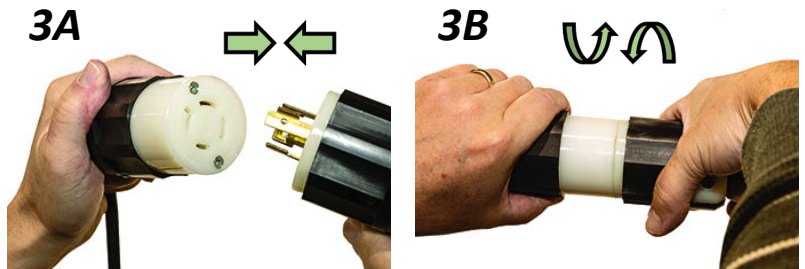

1..... Moving the lift point *forward* (away from operator) helps keep the hang angle vertical while the lifter is *loaded*; moving the lift point *rearward* (towards operator) helps keep the hang angle vertical while the lifter is *unloaded*.

# ASSEMBLY

4) Suspend the lifter from appropriate hoisting equipment:

4.1) Select a crane and/or hoist rated for the Maximum Load Capacity plus the Lifter Weight.

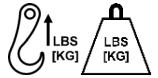

*Note: Any lifter use must comply with all statutory or regulatory standards for hoisting equipment in your region.*

4.2) Engage the tilt actuator to raise the lift bar (figs. 4A-B; see “TO TILT THE LOAD”).

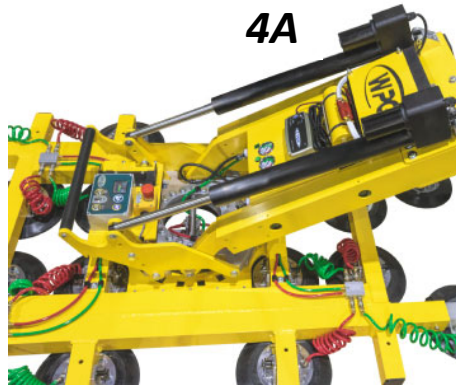

4.3) Attach the hoisting hook to the lift point (fig. 4C).

 **Make sure hook has restraining latch (arrow in fig. 4D).**



*Note: Use rigging (fig. 4E) as needed to make sure the hook does not interfere with the load.*

 **Only use rigging rated for Maximum Load Capacity plus Lifter Weight.**

4.4) Use the hoisting equipment to remove the lifter from the shipping container. Avoid damaging the vacuum pads.

5) Remove the pad covers (fig. 5A) and save them for future use.



6) Perform tests as required under “TESTING”.

# INTENDED USE

## LOAD CHARACTERISTICS

Make sure the vacuum lifter is intended to handle each load according to these requirements:



**Do NOT lift explosives, radioactive substances or other hazardous materials.**



- The load weight must not exceed the Maximum Load Capacity.
- The load must be a single piece of relatively nonporous material with a flat and relatively smooth contact surface.<sup>1, 2</sup> To determine whether the load is too porous or rough, perform the “[Lifter/Load Compatibility Test](#)”.
- The load's contact surface must be able to obtain a friction coefficient of 1 with the lifter's vacuum pads (see “[Pad-to-Load Friction Coefficient](#)”). Otherwise, the capacity should be derated appropriately.
- The load's surface temperature must not exceed the Operating Temperatures.<sup>3</sup>
- The load's *minimum* length and width are determined by the current Pad Spread (see “SPECIFICATIONS”).
- The load's *maximum* length and width are determined by its allowable overhang.<sup>4</sup>
- 1¼" [3 cm] is the allowable thickness at Maximum Load Capacity.<sup>5</sup>



*Note: Standard vacuum pads can stain or deform load surfaces with light colors or soft coatings. Test such surfaces for damaging effects before using the lifter on them.*<sup>6</sup>

1..... Although concave vacuum pads can also attach to some curved loads, curvature can reduce lifting capacity. Contact WPG for more information.

2..... A “single piece” of material includes curtainwall assemblies, unitized glazing systems and similar construction units.

3..... Vacuum pads made from a heat-resistant rubber compound can enable you to lift loads with higher surface temperatures. Contact WPG or an authorized dealer for more information.

4..... The allowable overhang is the amount of load material that can extend sideways beyond the vacuum pads without breaking or otherwise being damaged. This depends on the load material, its thickness, and the angle of handling (if any). Since every material has different physical properties, the allowable overhang must be evaluated separately for each load type. Contact WPG or an authorized dealer for more information.

5..... However, the allowable thickness increases as load weight decreases. Contact WPG for more information.

6..... Alternative rubber compounds are available for these purposes. Contact WPG or an authorized dealer for more information.

# INTENDED USE

## INDIRECT LOADING

Make sure to account for dynamic loading or other inadvertent loading that can negatively affect lifting capacity, such as:

- Weight amplification that results when a loaded vacuum lifter abruptly starts/stops moving, changes direction or bounces up and down (eg, when a telehandler transports a loaded lifter across rough terrain).
- External force that effectively increases the weight of a lifter's attached load (eg, when a load of sheet material reacts to wind gusts).



**Indirect loading can reduce lifting capacity.**

## OPERATING ENVIRONMENT

Make sure the lifter is suitable for each work environment, given the following restrictions:

- This lifter is not intended for any environment that is dangerous to the operator or damaging to the lifter. Avoid environments containing explosives, caustic chemicals and other dangerous substances.



**Never use lifter in dangerous environments.**



**Metal particles and similar environmental contaminants could result in vacuum pump failure.**

- The work environment is limited by the Operating Elevation and Operating Temperatures.<sup>1, 2</sup>
- The lifter is not designed to be watertight. Do not use it in rain or other unsuitable conditions.

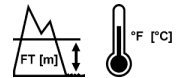

**Moisture can reduce lifting capacity.**

**CE/UKCA** — A secondary positive holding device is required to lift loads on construction sites.

## DISPOSAL OF THE LIFTER

After the Service Life of the lifter has ended (see "SPECIFICATIONS"), dispose of it in compliance with all local codes and applicable regulatory standards.

1..... Although lifter use may be possible at higher elevation, lifting capacity is reduced whenever the lifter is unable to attain vacuum in the green range on the vacuum gauge. Contact WPG for more information.

2..... Special provisions may allow the lifter to operate outside the specified temperature range. Contact WPG for more information.

## BEFORE USING THE LIFTER

Determine whether the vacuum lifter is capable of each intended task (see “SPECIFICATIONS” and “[INTENDED USE](#)”). Then complete the following preparations:

### Taking Safety Precautions

- Be trained in all industry and regulatory standards for lifter operation in your region.
- Follow trade association guidelines about precautions needed for each load material.



***Read all directions and safety rules before using lifter.***



***Always wear appropriate personal protective equipment.***

### Performing Inspections and Tests

- Follow the “[INSPECTION SCHEDULE](#)” and “[TESTING](#)”.
- Service the air filter whenever its bowl contains liquid or other contaminants or its element appears dirty (see “AIR FILTER MAINTENANCE” in [SERVICE MANUAL](#)).<sup>1</sup>



***Examine air filter regularly and service when needed.***

---

1..... Lifters used on wet load surfaces must be equipped with 2 or more filters connected *in series*. See “[OPERATING ENVIRONMENT](#)” for restrictions.

# OPERATION

## Moving the Control Pendant

For the operator's convenience, the movable control pendant can be moved from its main pendant holder on the lift bar to an alternate location on the pad frame, allowing easier control of the lifter's tilt and release functions.

- 1) Loosen the thumb screw for the main pendant holder (fig. 1A).
- 2) Slide the pendant out of the holder (fig. 2A).
- 3) Install the pendant in the alternate location (figs. 3A-B) and tighten its thumb screw, to secure (fig. 3C).

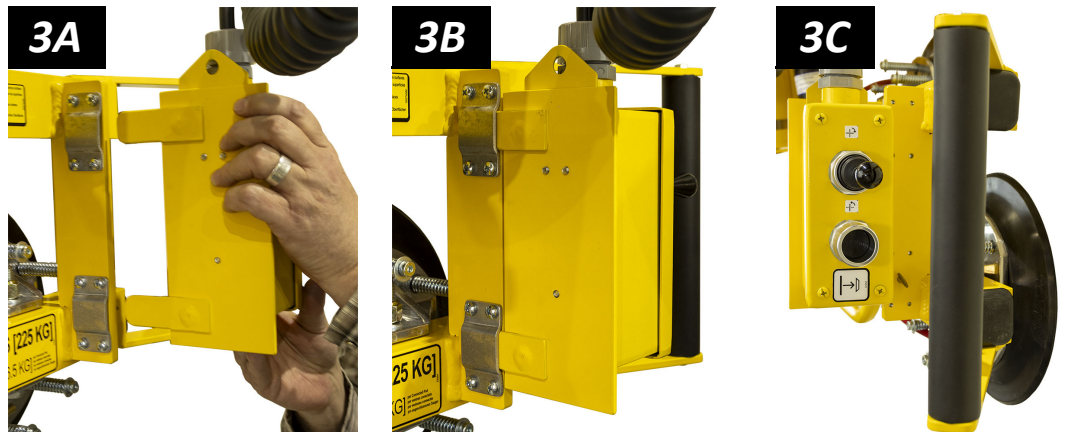
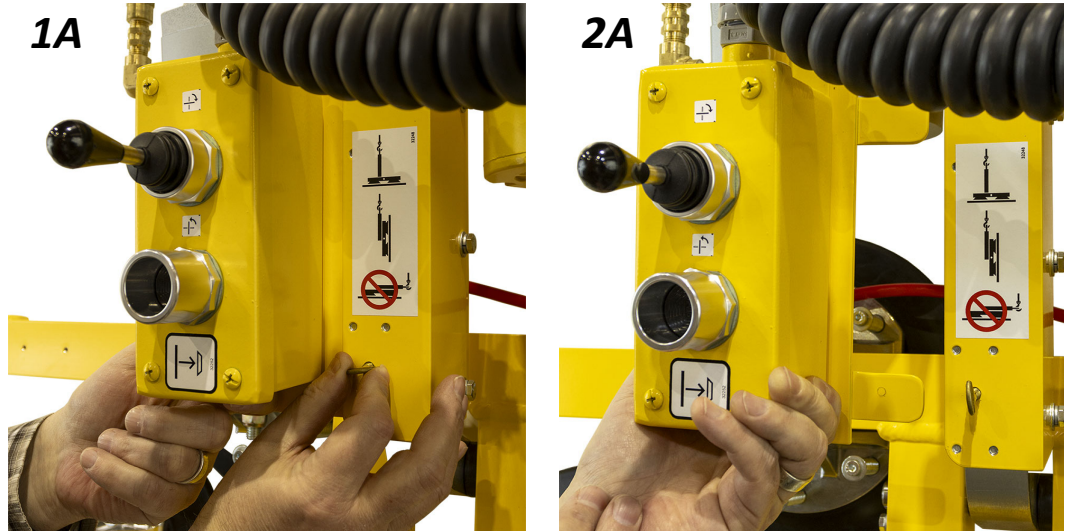

Reverse steps 1-3 to return the pendant to the main pendant holder, when desired.

## TO USE OPTIONAL PAD SHUTOFFS

Each pad shutoff on the pad frame controls the vacuum line to the adjacent vacuum pad. Activating or deactivating the airflow at specific pads enables the lifter to handle loads with different weights and dimensions (see “SPECIFICATIONS”) or to avoid holes in the load surface.

To support the maximum load weight and larger load dimensions, all pads must be activated; for smaller weights and dimensions, some pads may be deactivated, **provided that the lifter still has sufficient capacity to support the load** (see “LOAD CHARACTERISTICS”).



**Closing any pad shutoff reduces lifting capacity.**

To activate a pad, open the shutoff valve (ie, place lever *parallel* with vacuum line — fig. 1A).



To deactivate a pad, close the shutoff valve (ie, place lever *perpendicular* to vacuum line — fig. 1B).



To calculate the lifting capacity when some pads are deactivated, consult the Per-Pad Load Capacity and multiply by the number of pads currently activated. Always activate pads in a symmetrical configuration and use as many pads as possible for each load being lifted, to maximize lifting capacity and to minimize load overhang.



# OPERATION

## TO ATTACH THE PADS TO A LOAD

### Generating Airflow

Place the power switch in the “on” position ( | ), to engage the vacuum pump.<sup>1</sup>



**Keep pump running throughout lift.**

The lifter is designed for the vacuum pump to run continuously. Placing the power switch in the “off” position (○) during lifter operation could result in a load release and personal injury (see “[In Case of a Power Failure](#)”).

### Positioning the Lifter on the Load

- 1) Make sure the contact surfaces of the load and vacuum pads are clean (fig. 1A; see “[Pad Cleaning](#)”).

1A



- 2) Center the pad frame on the load (fig. 2A).<sup>2</sup>

2A



1..... If any powered component fails to function while the power switch is in the “on” position, make sure the lifter is connected correctly to an appropriate power source (see “ASSEMBLY”). If so, examine each circuit breaker (next to power switch) to determine whether it has interrupted the electrical circuit to the component. Although you can reset the circuit breaker, the power interruption may indicate an electrical problem that requires attention. Any fault must be corrected before resuming normal operation of the lifter.

2..... The lifter is designed to handle the maximum load weight when the load’s center of gravity is positioned within 2" [5 cm] of the pad frame’s center point.



# OPERATION

- 3) Make sure all vacuum pads will fit on the load and will be loaded evenly (fig. 3A).



Consult the Per-Pad Load Capacity.

- 4) Place the vacuum pads in contact with the load surface until they begin to seal.<sup>1</sup>

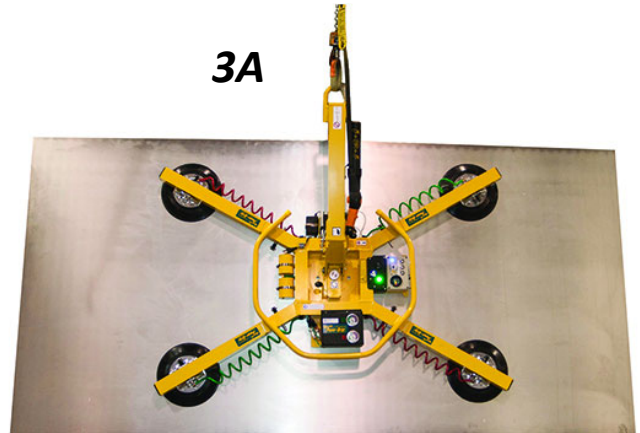

## Reading the Vacuum Gauge

A vacuum gauge shows the current vacuum level in positive inches of Hg and negative kPa:

- **Green range** ( $\geq 16$ " Hg [ $\leq -54$  kPa]): Vacuum level is sufficient to lift the maximum load weight (fig. 1B).
- **Red range** ( $< 16$ " Hg [ $> -54$  kPa]): Vacuum level is **not** sufficient to lift the maximum load weight (fig. 1C).



If it takes more than 5 seconds for the vacuum level to reach 5" Hg [-17 kPa], press on any vacuum pad that has not yet sealed.

Once the pads have sealed, the lifter should be able to maintain sufficient vacuum for lifting, except when used above the maximum Operating Elevation.<sup>2</sup> If it does not, perform the "Vacuum Test".

*Note: Disconnecting the movable control pendant during lifter operation is likely to result in a load release and personal injury.*



**Do not disconnect control pendant.**

1..... Although a vacuum pad may become distorted during shipping or storage, this condition should correct itself with continued use.

2..... If the lifter is used above the maximum Operating Elevation (see "SPECIFICATIONS"), it may not be able to maintain sufficient vacuum for lifting. Contact WPG for more information.

# OPERATION

## TO LIFT AND MOVE THE LOAD



***Lift bar must be vertical to lift load.***

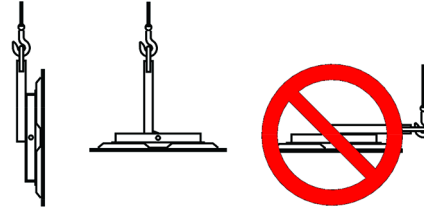

## Interpreting the Lift Light



When vacuum is sufficient to lift the Maximum Load Capacity, the vacuum lift light turns on automatically.



***Never lift load unless lift light is illuminated, because premature lifting could result in load release and personal injury.***

## Monitoring Vacuum Indicators

Monitor the vacuum lift light and the vacuum gauge (fig. 1A) throughout the entire lift.

The vacuum pump runs continuously to maintain sufficient vacuum for lifting the maximum load weight.

However, if the lift light turns off and the ***vacuum gauge shows a level less than 16" Hg [greater than -54 kPa]***:



***Make sure all vacuum indicators remain completely visible.***

- 1) Keep everyone away from a suspended load until it can be safely lowered to a stable support.
- 2) Stop using the lifter until the cause of the vacuum loss can be identified: Conduct the “[Pad Inspection](#)” and perform the “[Vacuum Test](#)”.
- 3) Correct any faults before resuming normal operation of the lifter.



***Stay clear of any suspended load while indicators warn of low vacuum.***

# OPERATION

## Controlling the Lifter and Load

When the lifter is ready, use the hoisting equipment to raise the lifter and load as needed.

Use a control handle (circled in fig. 1A) to keep the lifter and load in the required position.

Once there is enough clearance, you may move the load as required.

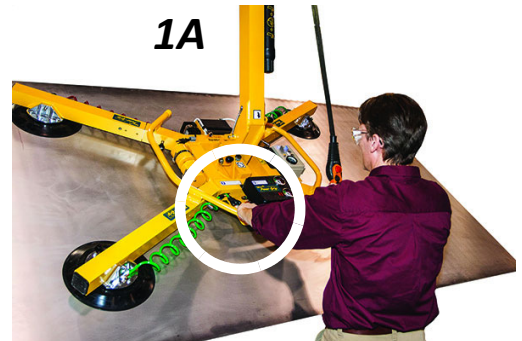

***Never allow any pad shutoff to be opened or closed while lifting, because this could result in a load release and personal injury.***

## In Case of a Power Failure

A vacuum reserve tank helps maintain vacuum temporarily in the event of a power failure. Although the lifter is designed to support the load for at least 5 minutes without power, this depends on many factors, including the “[LOAD CHARACTERISTICS](#)” and the condition of the vacuum pads (see “[VACUUM PAD MAINTENANCE](#)”).

If a power failure occurs, keep everyone away from a suspended load until it can be safely lowered to a stable support. Correct any faults before resuming normal operation of the lifter.



***Stay clear of any suspended load during power failure.***

# OPERATION

## TO TILT THE LOAD



**Make sure load is positioned correctly on lifter (as previously directed).**

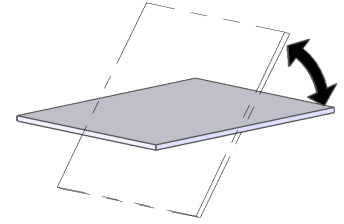

**Caution:** Unbalanced loads can interfere with the lifter's tilt capability, and it may also damage the lifter.

- 1) Make sure the load has enough clearance to tilt without contacting anyone or anything.
- 2) Use the tilt toggle switch on the movable control pendant to tilt the load as required:

- To move the load towards the *flat* position (fig. 2A), toggle *upward* (fig. 2A inset).

*Note: Release the toggle switch to stop the load in the current position.*

**2A**

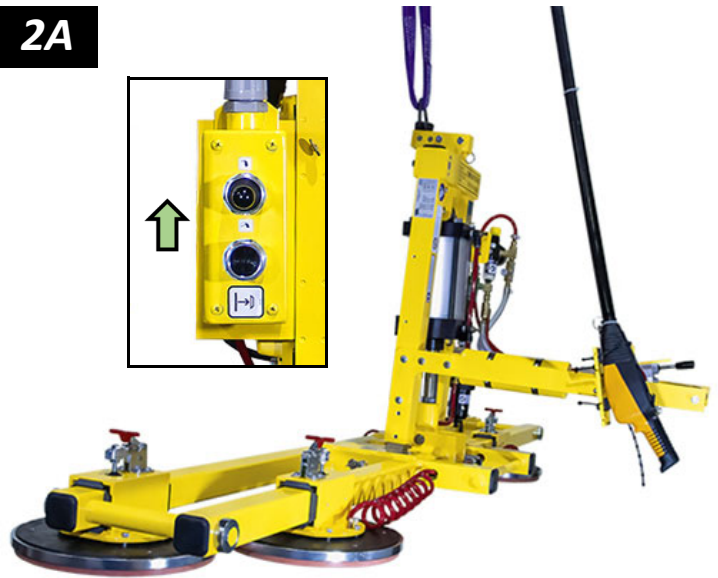
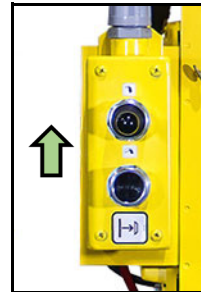

- To move the load towards the *upright* position (fig. 2B), toggle *downward* (fig. 2B inset).

*Note: Release the toggle switch to stop the load in the current position.*

**2B**

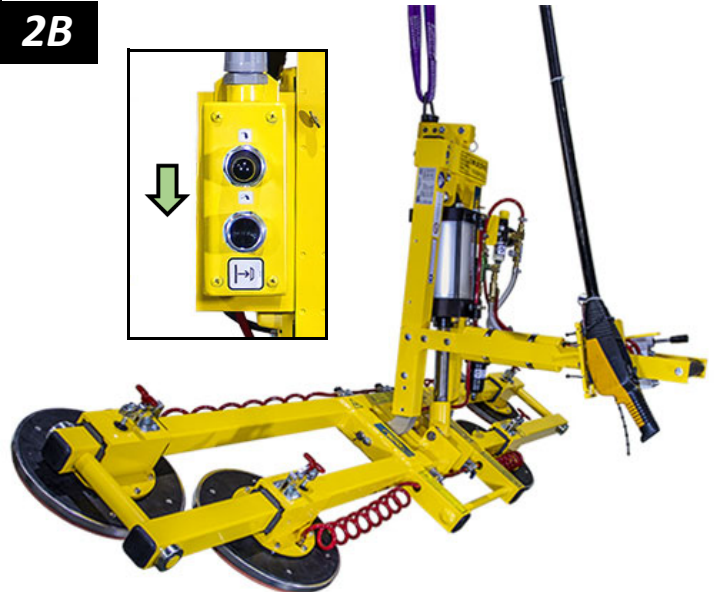
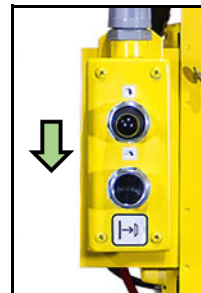

*Note: See "LOAD CHARACTERISTICS" for information about allowable overhang.*

# OPERATION

## TO RELEASE THE PADS FROM THE LOAD



***Make sure load is at rest and fully supported before releasing vacuum pads.***

- 1) Push the vacuum release button (|→) — circled in fig. 1A) on the movable control pendant, to break the vacuum seal.



- 2) Continue to hold the release button until the vacuum pads release the load completely. Otherwise, the lifter will automatically reattach.



***Do not move lifter until pads release completely, because such movement could result in load damage or personal injury.***

- 3) Before you lift another load, perform the Every-Lift Inspection (see “[INSPECTION SCHEDULE](#)”).

1..... Spacers are integrated into the original shipping container. Use similarly shaped spacers when setting the lifter on other surfaces.

# OPERATION

## AFTER USING THE LIFTER

- 1) Place the power switch in the “off” position (○).
- 2) Use the hoisting equipment to lower the vacuum lifter gently onto a stable support. Then detach the hoisting hook from the lift point.

**Caution:** Do not set the lifter on surfaces that could soil or damage vacuum pads. If the lifter is equipped with VPFS10T pads, protect their sealing rings by making sure each pad rests on spacers.<sup>1</sup>



## Storing the Lifter

- 1) Disconnect the electrical connectors (figs. 1A-B).

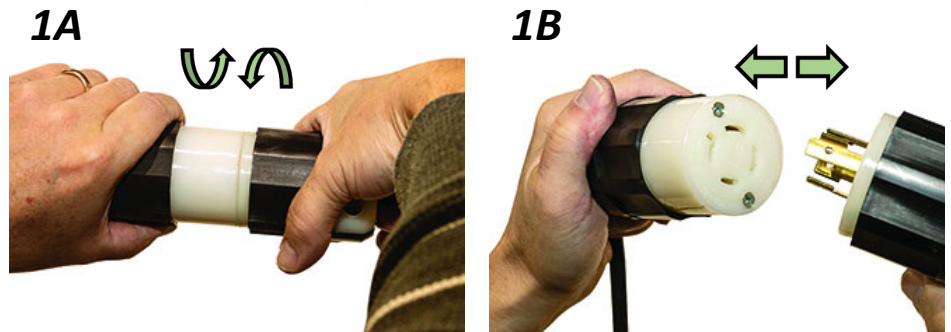

- 2) Use the covers supplied to keep the vacuum pads clean (fig. 2A).

**CE/UKCA** — To prevent the lifter from tipping over on relatively horizontal surfaces, place the vacuum pads facedown on a clean, smooth, flat surface. Then lower the lift bar and place a support under the lift point.<sup>1</sup>



- 3) Store the lifter in a clean, dry location.

## Transporting the Lifter

Secure the lifter in the original shipping container with the original shipping materials or equivalent.

<sup>1</sup>..... Storing the lifter without placing a support under the lift bar can result in damage to the tilt actuator.

# INSPECTIONS AND TESTS

## INSPECTION SCHEDULE

Perform inspections according to the following frequency schedule. If any fault is found, correct it and perform the next most frequent inspection before using the vacuum lifter.

*Note: If a lifter is used less than 1 day in a 2-week period, perform the Periodic Inspection before using it.*

Action	Every Lift	Frequent <sup>1</sup> (every 20-40 hrs)	Periodic <sup>2</sup> (every 250-400 hrs)
Examine <u>vacuum pads</u> for contaminants or damage (see “ <a href="#">Pad Inspection</a> ”).	✓	✓	✓
Examine load surface for contaminants or debris.	✓	✓	✓
Examine controls and indicators for damage.	✓	✓	✓
Examine lifter’s structure for damage.		✓	✓
Examine vacuum system for damage (including <u>vacuum pads</u> , fittings and hoses).		✓	✓
Examine <u>air filter</u> for conditions requiring service (see “AIR FILTER MAINTENANCE” in <a href="#">SERVICE MANUAL</a> ).		✓	✓
Perform “ <a href="#">Vacuum Test</a> ”.		✓	✓
Check for unusual vibrations or noises while operating lifter.		✓	✓
Examine entire lifter for evidence of: <ul style="list-style-type: none"> <li>• looseness, excessive wear or excessive corrosion</li> <li>• deformation, cracks, dents to structural or functional components</li> <li>• cuts in vacuum pads or hoses</li> <li>• any other hazardous conditions</li> </ul>			✓
Inspect entire electrical system for damage, wear or contamination that could be hazardous, in compliance with all local codes and regulatory standards. <b>Caution:</b> Use appropriate cleaning methods for each electrical part, as specified by codes and standards. Improper cleaning can damage parts.			✓

1..... The Frequent Inspection is also required whenever the lifter has been out of service for 1 month or more.

2..... The Periodic Inspection is also required whenever the lifter has been out of service for 1 year or more. Keep a written record of all Periodic Inspections. If necessary, return the lifter to WPG or an authorized dealer for repair (see “[REGISTRATION AND LIMITED WARRANTY](#)”).

## TESTING

Perform the following test to determine whether or not a load surface is too porous or rough:

### Lifter/Load Compatibility Test<sup>1</sup>

- 1) Make sure the vacuum generating system is functioning correctly (see “[Vacuum Test](#)”).
- 2) Thoroughly clean the load surface and the vacuum pads (see “[Pad Cleaning](#)”).
- 3) Place the load in the upright position on a stable support.
- 4) Attach the vacuum pads to the load as previously directed.
- 5) After the vacuum level appears in the green range on the vacuum gauge, place the power switch in the “off” position (○).
- 6) Raise the load a minimal distance, to make sure it is supported by the lifter.
- 7) Watch the vacuum gauge: ***Starting from a vacuum level of 16" Hg [-54 kPa], the lifter must maintain a vacuum level greater than 12" Hg [less than -41 kPa] for 5 minutes.***<sup>2</sup> If not, lifting this load requires additional precautions (eg, a load sling). Contact WPG for more information.
- 8) Lower the load *after* 5 minutes or *before* the vacuum level diminishes to 12" Hg [increases to -41 kPa].



***Take precautions in case load should fall during test.***

1..... The “[Pad-to-Load Friction Coefficient](#)” can affect the outcome of this test.

2..... Under CE and UKCA requirements, the lifter must maintain a vacuum level ***greater than 8" [less than -27 kPa]***.



# INSPECTIONS AND TESTS

Perform the following tests before placing the lifter in service *initially, following any repair,* when directed in the “*INSPECTION SCHEDULE*”, or *whenever necessary*:

## Operational Tests

Test all features and functions of the lifter (see “OPERATING FEATURES” and “OPERATION”).

## Vacuum Test

- 1) Clean the faces of the vacuum pads (see “*Pad Cleaning*”).
- 2) Use a test load with weight equal to the Maximum Load Capacity, a clean, smooth, nonporous surface and other appropriate “*LOAD CHARACTERISTICS*”.<sup>1</sup>
- 3) Attach the lifter to the test load as previously directed.
- 4) After the vacuum level appears in the green range on the vacuum gauge, raise the load a minimal distance and place the power switch in the “off” position (○).
- 5) Watch the vacuum gauge: *The vacuum level should not decrease by more than 4" Hg [increase by more than -14 kPa] in 5 minutes.*
- 6) Lower the load after 5 minutes or whenever a lifter fails the test, and release the load as previously directed.
- 7) Qualified service personnel must correct any fault in the vacuum system before returning the lifter to service.



**Take precautions in case load should fall during test.**



**Never use lifter that has failed test.**



**This service must be performed by qualified service personnel.**

1..... The load should have either a flat surface or no more curvature than the lifter is designed for, if any.

# INSPECTIONS AND TESTS

## Rated Load Test<sup>1</sup>

The following steps must be performed or supervised by a qualified person:<sup>2</sup>

- 1) Use a test load that weighs 125% ( $\pm 5\%$ ) of the Maximum Load Capacity and has the appropriate “LOAD CHARACTERISTICS”. 
- 2) Attach the vacuum pads to the load as previously directed.
- 3) Position the load to produce the greatest stress on the lifter consistent with “INTENDED USE”.
- 4) Raise the load a minimal distance and leave it suspended for 2 minutes.
- 5) Once the test is completed, lower the load for release as previously directed.
- 6) Inspect the lifter for any stress damage, and repair or replace components as necessary to successfully pass the test.
- 7) Prepare a written report of the test and keep it on file.



***Take precautions in case load should fall during test.***



***Never use lifter that has failed test.***

---

1..... An equivalent simulation may also be used. Contact WPG for more information.

2..... A “qualified person” has successfully demonstrated the ability to solve problems relating to the subject matter and work, either by possessing a recognized degree in an applicable field or a certificate of professional standing, or by possessing extensive knowledge, training and experience.

# MAINTENANCE

Note: Refer to **SERVICE MANUAL #35275** when applicable.

## VACUUM PAD MAINTENANCE

### Pad-to-Load Friction Coefficient

The friction coefficient represents the lifter's ability to resist load slippage. The Maximum Load Capacity is based on a friction coefficient of 1, as determined by testing of clean, new, standard rubber vacuum pads on clean, dry, regular glass. **If the lifter is used under any other conditions, a qualified person must first determine the effective lifting capacity.**<sup>1</sup>



Long-term exposure to heat, chemicals or UV light can damage vacuum pads. Replace pads and sealing rings (if applicable) every 2 years or more often when necessary.

### Pad Inspection

Inspect each vacuum pad (fig. 1A) according to the “**INSPECTION SCHEDULE**” and correct the following faults before using the lifter (see “**REPLACEMENT PARTS**”, when applicable):

- Contaminants on the face (item 1 in fig. 1A) or sealing edges (item 2 in fig. 1A).
- Filter screen (item 3 in fig. 1A) missing from face.



**Replace any pad that has damaged sealing edges.**

- Nicks, cuts, deformation or abrasions in sealing edges.<sup>2</sup>
- Wear, stiffness or glaze.

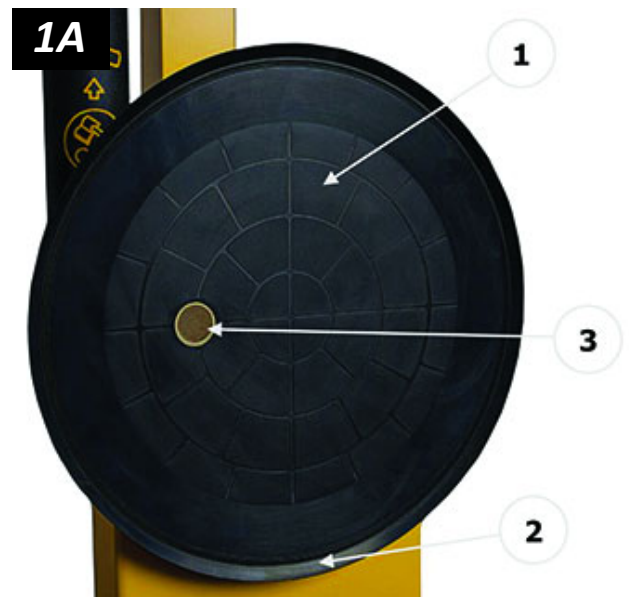

1..... A “qualified person” has successfully demonstrated the ability to solve problems relating to the subject matter and work, either by possessing a recognized degree in an applicable field or a certificate of professional standing, or by possessing extensive knowledge, training and experience.

2..... If the lifter has VPFS10T pads, the replaceable sealing ring is the sealing edge.

## Pad Cleaning

- 1) Regularly clean the face of each vacuum pad (fig. 1A), using soapy water or other mild cleansers to remove oil, dust and other contaminants.



***Never use harsh chemicals on vacuum pad.***

Solvents, petroleum-based products (including kerosene, gasoline and diesel fuel) or other harsh chemicals can damage vacuum pads.



***Never use rubber conditioners on vacuum pad.***

Many rubber conditioners can leave a hazardous film on vacuum pads.

- 2) Prevent liquid from entering the vacuum system through the suction hole on the pad face.
- 3) Wipe each pad face clean, using a clean sponge or lint-free cloth to apply the cleanser.<sup>1</sup>
- 4) Allow each pad to dry completely before using the lifter.

**1A**



<sup>1</sup>..... A brush with bristles *that do not harm rubber* can help remove contaminants clinging to sealing edges. If these cleaning methods are not successful, contact WPG or an authorized dealer for assistance.

# ← MAINTENANCE →

## TO REPLACE SEALING RING IN VPFS10T PADS

If the lifter has VPFS10T vacuum pads, replace sealing rings (**#49724RT** or **#49724TT**) as follows:

- 1) Remove the old sealing ring (fig. 1A).

*Note: Make sure the entire vacuum pad is clean, including the mounting groove.*

- 2) Place the inside edge of a new sealing ring against the inside edge of the mounting groove (fig. 2A).

- 3) Push the sealing ring into the mounting groove, beginning in 4 locations as shown circled in fig. 3A.

- 4) Push gently and firmly on the outside edge of the sealing ring until the flat side fits flush against the bottom of the mounting groove (fig. 4A). A pad ring installation tool (circled in fig. 4A) makes this step easier (see “REPLACEMENT PARTS”).

- 5) Make sure the sealing ring seats securely in the mounting groove, all the way around the vacuum pad (fig. 5A).

1A



2A



3A

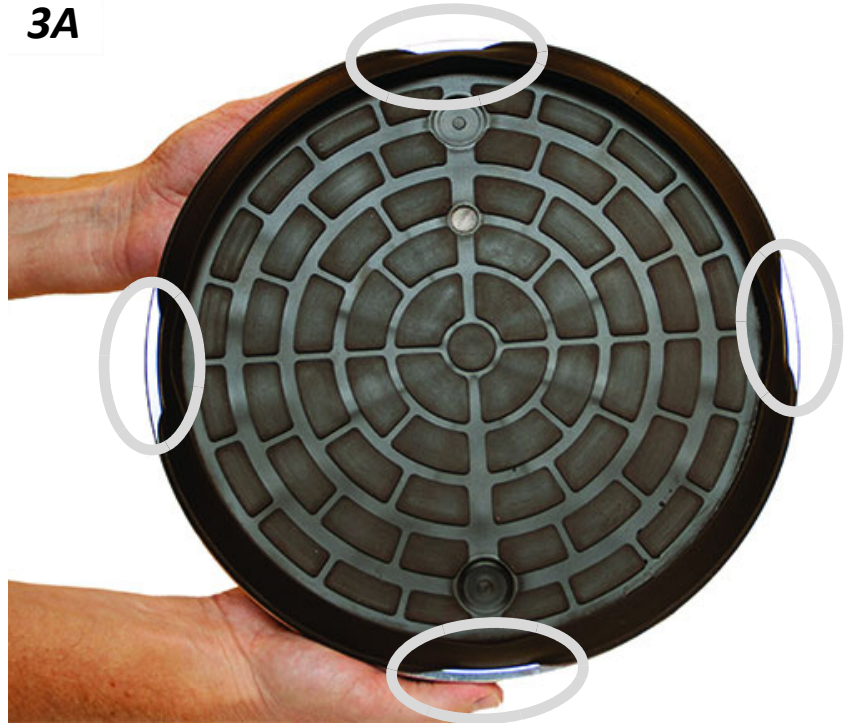

4A



5A



*Note: If any part of the sealing ring comes out of the mounting groove, inspect the sealing ring for damage and reinstall an undamaged sealing ring.*

# REPLACEMENT PARTS

Stock No.	Description	Qty.
93011	Pad Shutoff Valve Assembly (optional retrofit assembly kit)	4
93012	Pad Shutoff Valve Assembly (optional; assembly only)	4
65444	Vacuum Hose – 1/2" ID x 0.748" OD – Clear	*
65440	Vacuum Hose – 0.245" ID x 3/8" OD – Red	*
65301	Handle Grip Foam	*
65010	Pad Spring – Coil Type	4
64289	Bulb - 24 V – Bayonet (for vacuum lift light)	1
64262	Green Lens (for vacuum lift light)	1
53132	Hose Fitting – Tee – 5/32" ID	3
53120	Pad Fitting – Elbow – 3/64" ID	4
49724TT	Sealing Ring for VPFS10T Pad – Closed Cell Foam	4
49724RT	Sealing Ring for VPFS10T Pad – Heat-Resistant Rubber	4
49672FT	Vacuum Pad – Model VPFS10T / 10" [25 cm] Diameter – w/Replaceable Sealing Ring	4
49506TA	Vacuum Pad – Model VPFS9 / 9" [23 cm] Diameter	4
49150	End Plug – 2-1/2" x 2-1/2" x 1/4" Tubing Size	4
35275	Service Manual – AC	1
29353	Pad Cover	4
20050	Pad Ring Installation Tool (for VPFS10T pads)	1
15632	Pad Filter Screen – Small	4
10900	Shoulder Bolt – Socket Head – 5/16" X 1/2" X 1/4-20 Thread (for mounting pads)	24

\*Length as required; sold by the inch (approx 2.5 cm).

See **SERVICE MANUAL #35275** for additional parts.

**SERVICE ONLY WITH IDENTICAL REPLACEMENT PARTS,  
AVAILABLE AT [WPG.COM](http://WPG.COM) OR THROUGH AN AUTHORIZED WPG DEALER**

# REGISTRATION AND LIMITED WARRANTY

## TO REGISTER THIS WPG PRODUCT

Go to the [PRODUCT REGISTRATION](#) page at [wpg.com](#) and complete the form. Registration keeps you advised of important updates and notifications, and simplifies inquiries to WPG regarding your product. Registration is **not** required to activate your Limited Warranty (see next section).

## ABOUT THE LIMITED WARRANTY



*Note: Read the [WARRANTY RETURN FORM](#) at [wpg.com](#) for important details about the Limited Warranty.*

Wood's Powr-Grip® (WPG) products are warranted to be free from defects in manufacturing and materials for 1 year from the date of purchase.

If a problem develops during the warranty period, follow the instructions below to obtain warranty service. If inspection shows that the product has a defect, WPG will repair or replace the product without charge.



## Obtaining Warranty Service or Repair Service

**For customers in the U.S. and Canada:** Go to the [EXCHANGES, REPAIRS, & WARRANTIES](#) page at [wpg.com](#) and click the applicable link. Alternatively, you may contact the WPG Technical Service Department (see contact information below).

**For customers in all other localities:** Contact the WPG Technical Service Department (see contact information below) or your dealer for assistance.

ADDRESS	EMAIL	PHONE
Wood's Powr-Grip Co., Inc. 908 West Main St. Laurel, MT USA 59044	<a href="mailto:contactus@wpg.com">contactus@wpg.com</a>	(1) 800-548-7341 (1) 406-628-8231

KEEP FOR FUTURE REFERENCE

# ENGINEERING DRAWINGS

 INTENDED FOR USE BY QUALIFIED SERVICE  
PERSONNEL • READ AND UNDERSTAND BEFORE  
ROUTING, WIRING AND/OR ASSEMBLING



908 W. Main • P.O. Box 368  
Laurel, MT USA 59044  
(1) 800-548-7341  
(1) 406-628-8231  
[www.wpg.com](http://www.wpg.com)

**POWER TILTER,  
AC-VOLTAGE**

Model number: PT49AC, PT410TACO



TYPE: <b>STANDARD</b>	DIRECTORY: <b>700-W01 [W01]</b>
WIRE LEGEND: CONTROLLED BY WIRING SYMBOLS DRAWING EXCEPT AS NOTED AND BELOW. LINE STYLES AND WIDTHS FOR WIRE UNLESS NOTED OTHERWISE. --- N/A --- --- 16AWG --- --- N/A --- --- N/A ---	
DRAWN: <b>L. RENNER</b>	DATE: <b>03/03/2005</b>
CHECKED: <b>CR</b>	
APPROVED: <i>[Signature]</i>	DATE: <b>04-02-12</b>
SIZE: <b>A</b>	SCALE: <b>NONE</b>
REV: <b>1</b>	ECN NUMBER: <b>2762</b>
DATE: <b>12/09/2011</b>	BY: <b>LER</b>

H:\Working\STD\700-STD\700-W01 [W01]  
**WOOD'S POWR-GRIP CO., INC.**  
 LAUREL, MONTANA U.S.A.

STANDARD PARTS  
 N/A  
**120/240VAC GAST 4 SCFM VACUUM PUMP WIRING SCHEMATIC**  
 D700-W01 [W01]

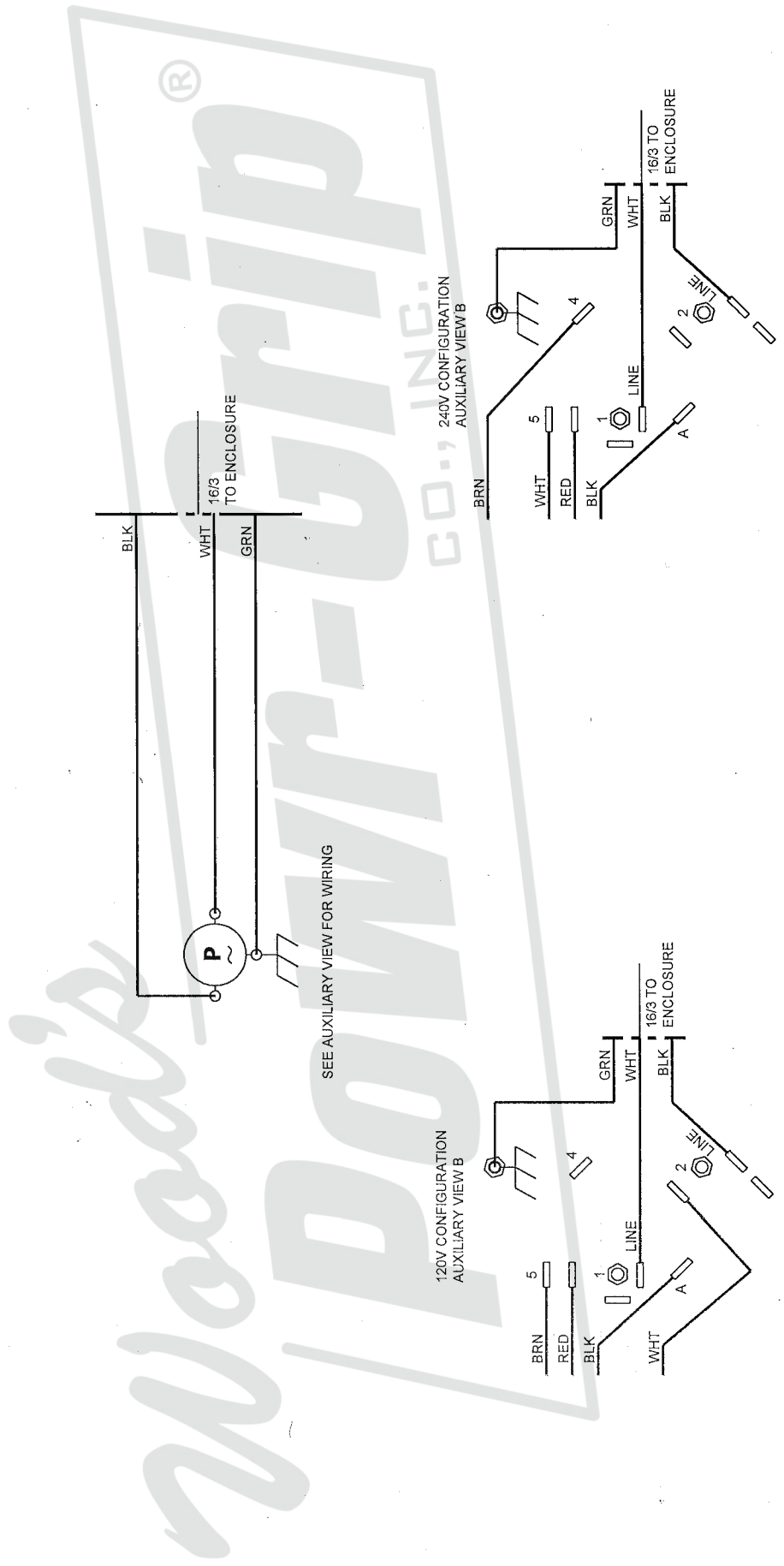

TYPE: STANDARD

FILE DIRECTORY: 716-001 [A-W01]

THIS DRAWING IS THE PROPERTY OF WOOD'S POWR-GRIP CO., INC. LAUREL, MONTANA U.S.A. IT IS LOANED WITH THE UNDERSTANDING THAT NEITHER IT NOR ANY INFORMATION CONTAINED THEREIN WILL BE COPIED, PUBLISHED OR TRANSMITTED TO OTHERS WITHOUT EXPRESS WRITTEN PERMISSION.

STANDARD FLOW SOLENOID VALVE PACKAGE

POWER TILT

24V AC VALVE ENCLOSURE W/ RELAYS WIRING DIAGRAM  
D716-W01 [A-W01]

SIZE: A	SCALE: NONE	REVISION: 01.A	ECN NUMBER: 3683	ECN DATE: 03/11/2015	ECN BY: SPE	EST. WEIGHT: N/A
---------	-------------	----------------	------------------	----------------------	-------------	------------------

WIRE LEGEND: CONTROLLED BY WIRING SYMBOLS DRAWING EXCEPT AS NOTED AND BELOW.

LINE STYLES AND WIDTHS FOR WIRE UNLESS NOTED OTHERWISE:

--- N/A ---  
--- 20AWG ---  
--- 18AWG ---  
--- 16AWG ---

PRODUCT MANAGER: DANIEL M.

DATE: 04/19/2002

CHECKED: *CL*

APPROVED: *CLM*

06-30-15

6-30-15

NOTES:  
1) MAY SUBSTITUTE GRN W/ YS FOR GRN.

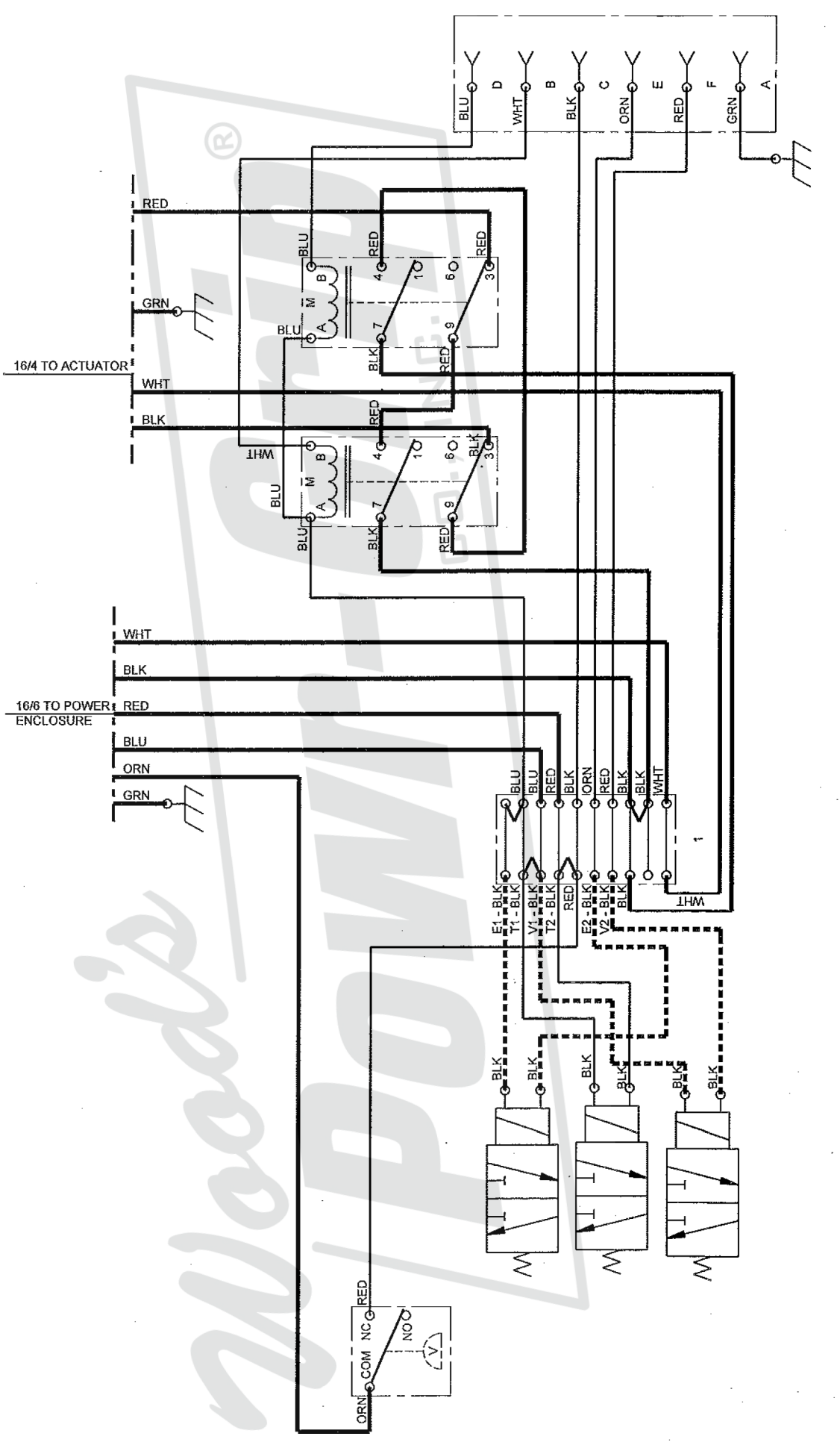

FILE DIRECTORY:  
FILE [SHEET]:

STANDARD

716-W02 [A-W02]

THIS DRAWING IS THE PROPERTY OF **WOOD'S POWR-GRIP CO., INC.** LAUREL, MONTANA U.S.A.  
IT IS LOANED WITH THE UNDERSTANDING THAT NEITHER IT NOR ANY INFORMATION CONTAINED THEREIN WILL BE COPIED, PUBLISHED OR TRANSMITTED TO OTHERS WITHOUT EXPRESS WRITTEN PERMISSION.



STANDARD-FLOW SOLENOID-VALVE PACKAGE

POWER-TILT

AC 1-ACTION RELEASE W/POWER TILT PENDANT WIRING SCHEM  
D716-W02 [A-W02]

SIZE: SCALE: A NONE REVISION: 03.A ECN NUMBER: 4631 ECN DATE: 07/12/2018 ECN BY: CCH EST. WEIGHT: N/A

WIRE LEGEND: CONTROLLED BY WIRING SYMBOLS DRAWING EXCEPT AS NOTED AND BELOW.

LINE STYLES AND WIDTHS FOR WIRE UNLESS NOTED OTHERWISE.

..... N/A  
- - - - - N/A  
- - - - - N/A  
- - - - - N/A  
- - - - - N/A

PRODUCT MANAGER: DANIEL M. DATE: 03/26/2002

CHECKED: CR

APPROVED: *Over*

- NOTES:
- (1) SUBSTITUTE YELLOW WIRE FOR BLUE IF BLUE WIRE IS UNAVAILABLE.
  - (2) SUBSTITUTE BROWN WIRE FOR ORANGE IF ORANGE WIRE IS UNAVAILABLE.

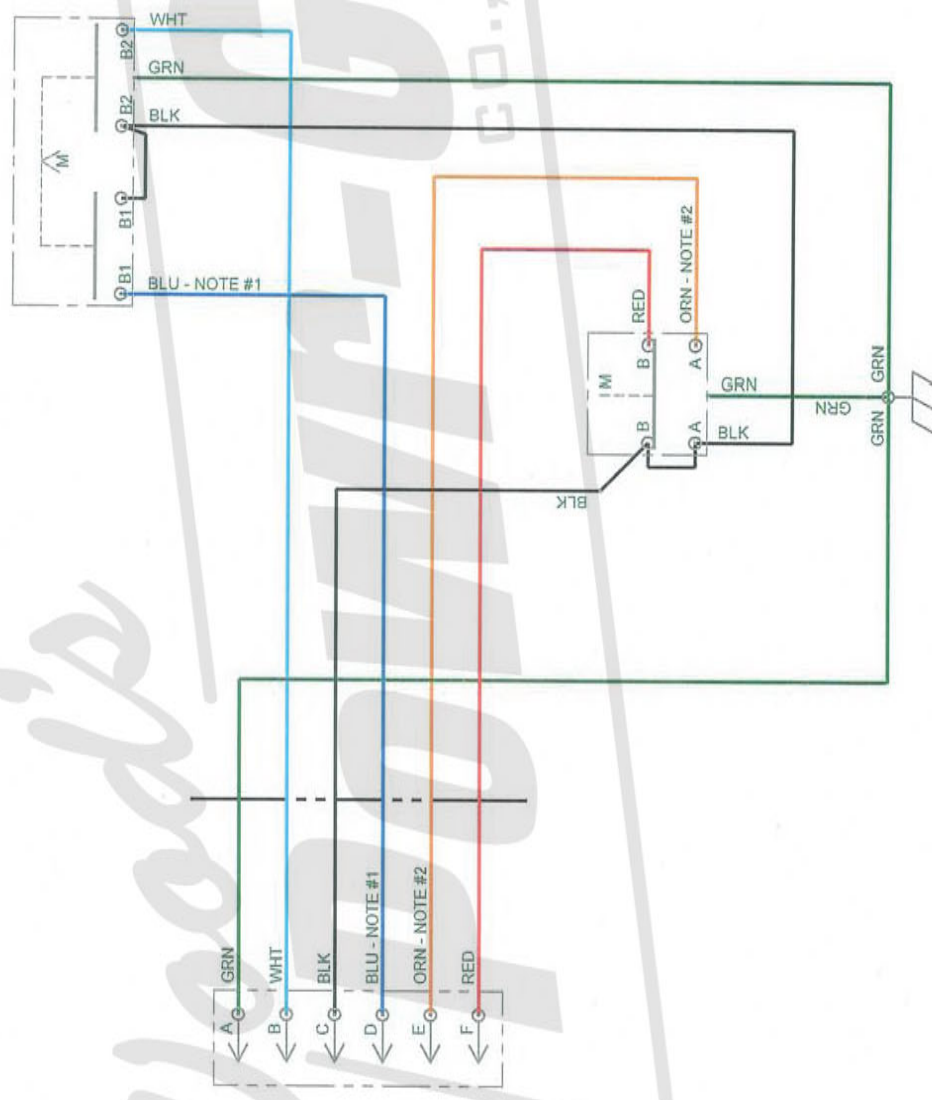

TYPE: <b>STANDARD</b>	FILE DIRECTORY: <b>716</b>	FILE (SHEET): <b>716A-W03 [A-W03]</b>
THIS DRAWING IS THE PROPERTY OF <b>WOOD'S POWR-GRIP CO., INC.</b> , LAUREL, MONTANA U.S.A. IT IS LOANED WITH THE UNDERSTANDING THAT NEITHER IT NOR ANY INFORMATION CONTAINED THEREIN WILL BE COPIED, PUBLISHED OR TRANSMITTED TO OTHERS WITHOUT EXPRESS WRITTEN PERMISSION.		
STANDARD FLOW SOLENOID VALVE PACKAGE POWER TILT ACTUATOR WIRING DIAGRAM D716A-W03 [A-W03]		
SIZE: <b>A</b>	SCALE: <b>NONE</b>	REVISION: <b>01A</b>
ECN NUMBER: <b>3683</b>	ECN DATE: <b>03/11/2015</b>	EST. WEIGHT: <b>N/A</b>

WIRE LEGEND: CONTROLLED BY WIRING SYMBOLS DRAWING EXCEPT AS NOTED AND BELOW.

LINE STYLES AND WIDTHS FOR WIRE UNLESS NOTED OTHERWISE.

- - - - - N/A  
 - - - - - N/A  
 - - - - - 16AWG

PRODUCT MANAGER: **DANIEL M.**  
 DATE: **05/29/2007**  
 CHECKED: **CR**  
 APPROVED: **CR**

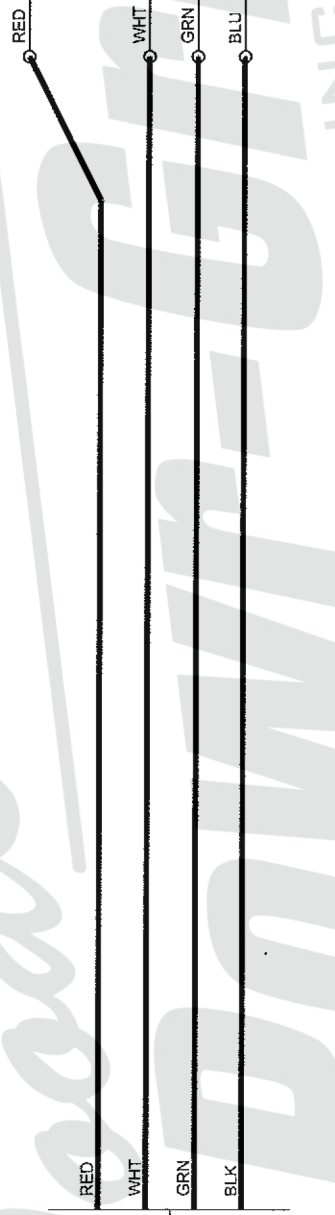
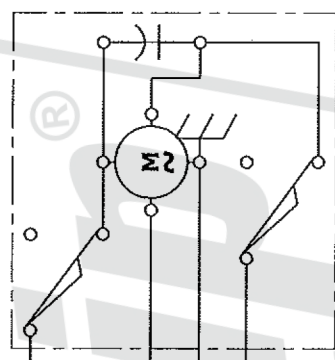

TO VALVE ENCLOSURE

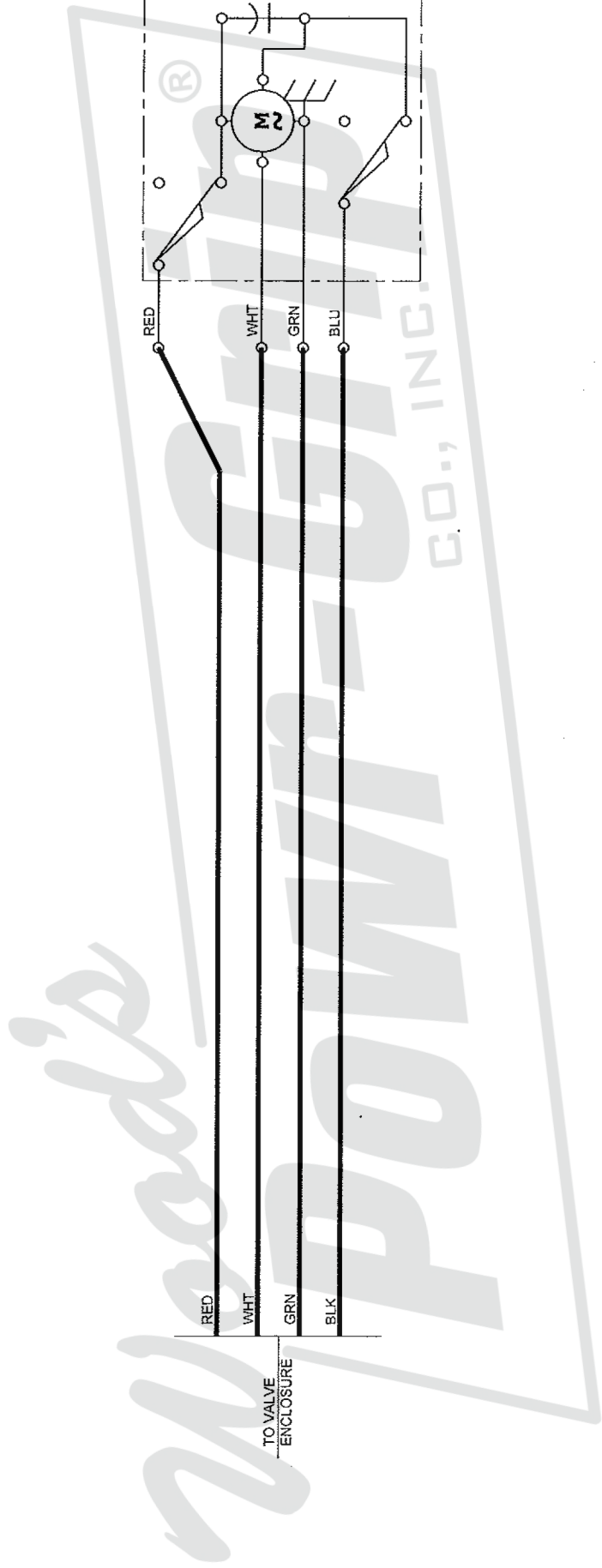

TYPE: STANDARD

FILE DIRECTORY: 716B-W01 [C-W01]

THIS DRAWING IS THE PROPERTY OF **WOOD'S POWR-GRIP CO., INC.** LAUREL, MONTANA U.S.A. IT IS LOANED WITH THE UNDERSTANDING THAT NEITHER IT NOR ANY INFORMATION CONTAINED THEREIN WILL BE COPIED, PUBLISHED OR TRANSMITTED TO OTHERS WITHOUT EXPRESS WRITTEN PERMISSION.

STANDARD-FLOW SOLENOID-VALVE PACKAGE TRANSFORMER ENCLOSURE W/POWER TILT POWER SWITCH ENCLOSURE W/TILT WIRING SCHEMATIC D716B-W01 [C-W01]

SIZE: <b>A</b>	SCALE: <b>NONE</b>	REVISION: <b>03.A</b>	ECN NUMBER: <b>4263</b>	ECN DATE: <b>02/06/2017</b>	EST. WEIGHT: <b>N/A</b>
CHECKED: <i>CR</i>	APPROVED: <i>CR</i>	DATE: <b>09/13/2006</b>	DATE: <i>02-14-17</i>	DATE: <i>2-14-17</i>	
PRODUCT MANAGER: <b>DANIEL M.</b>					

WIRE LEGEND: CONTROLLED BY WIRING SYMBOLS DRAWING EXCEPT AS NOTED AND BELOW. LINE STYLES AND WIDTHS FOR WIRE UNLESS NOTED OTHERWISE. N/A... 20AWG... N/A... 16AWG... N/A... 14AWG... NOTE #1... N/A... 14AWG

TO VACUUM PUMP OR CAPACITOR ENCLOSURE

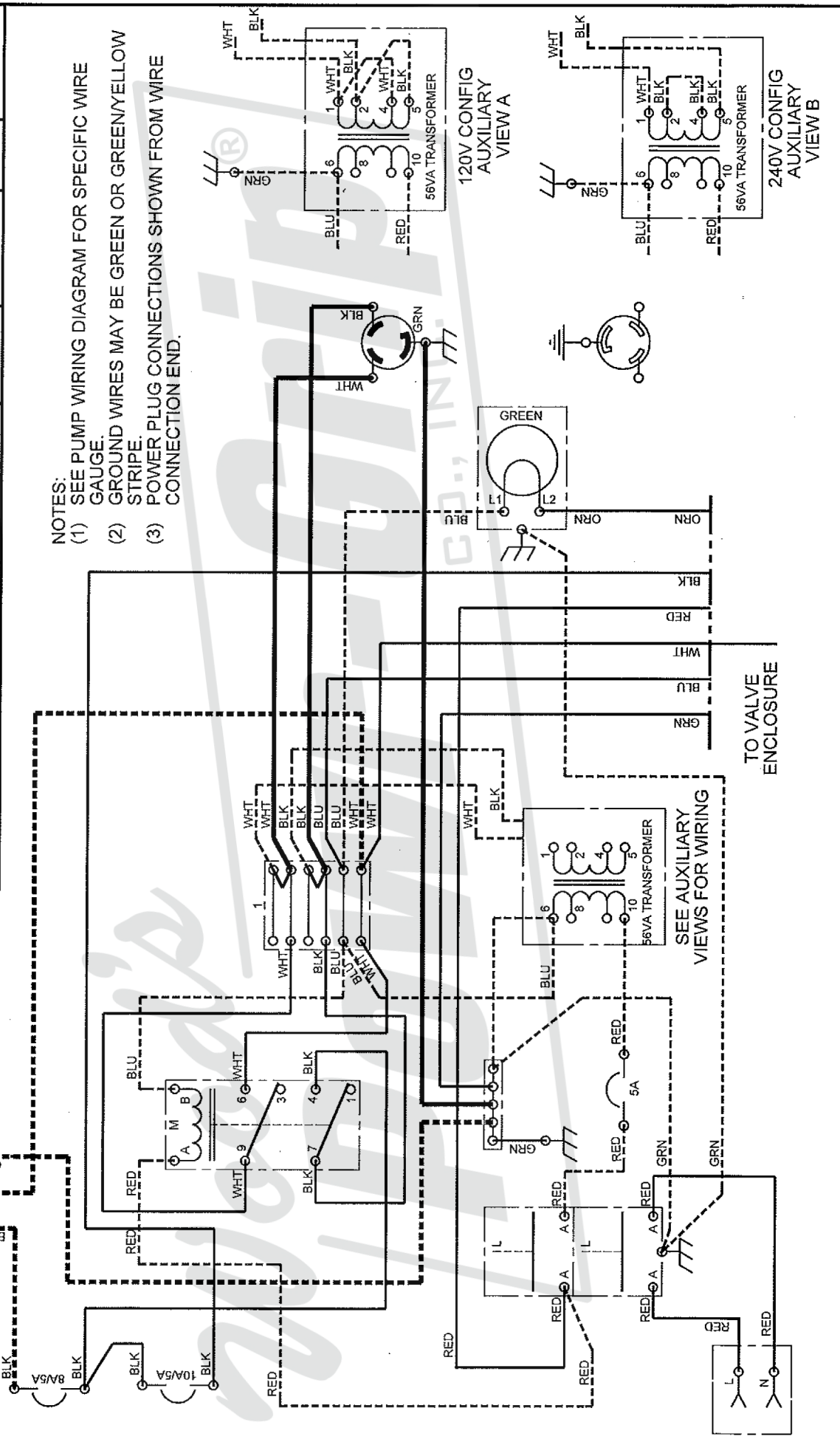

- NOTES:
- (1) SEE PUMP WIRING DIAGRAM FOR SPECIFIC WIRE GAUGE.
  - (2) GROUND WIRES MAY BE GREEN OR GREEN/YELLOW STRIPE.
  - (3) POWER PLUG CONNECTIONS SHOWN FROM WIRE CONNECTION END.

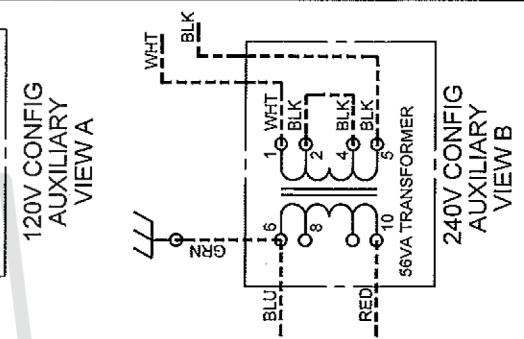
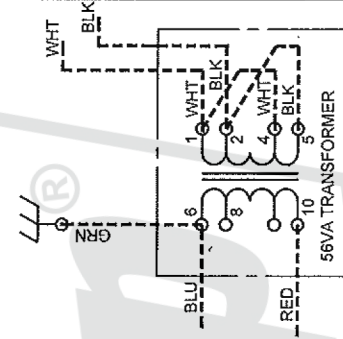

SEE AUXILIARY VIEWS FOR WIRING

TO VALVE ENCLOSURE