

**KEEP FOR FUTURE REFERENCE**



*P.O. Box 368 – 908 West Main  
Laurel, MT USA 59044  
phone 800-548-7341  
phone 406-628-8231  
fax 406-628-8354*

# INSTRUCTIONS

International Version

MODEL NUMBER: PT4FS10TAIR

SERIAL NUMBER: \_\_\_\_\_

(please see serial label and record number here)

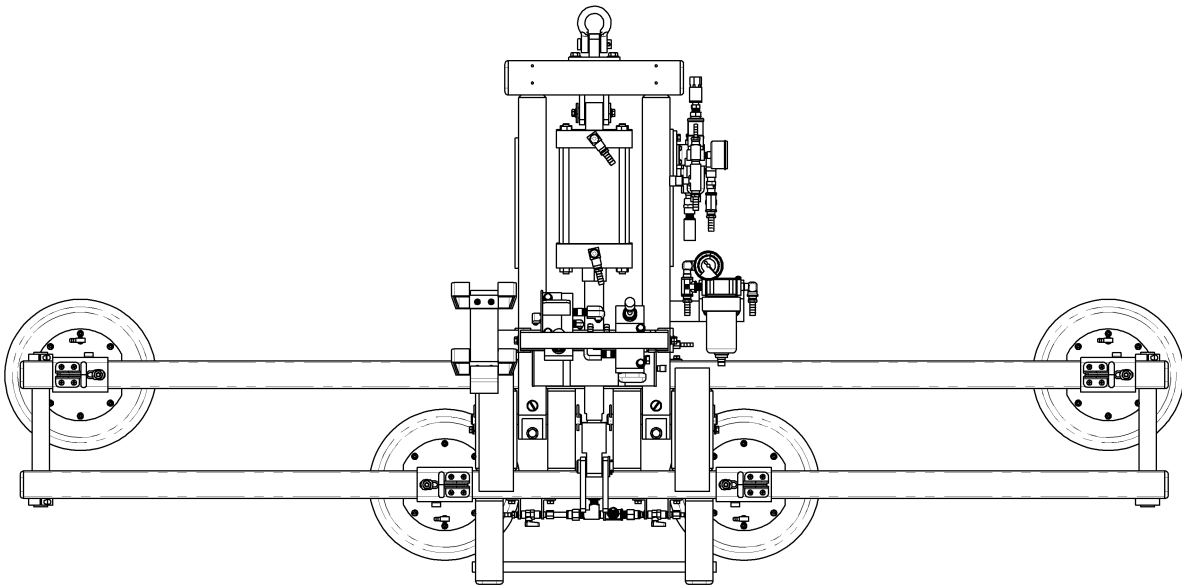

**POWER TILTER  
AIR-POWERED**



***READ ALL INSTRUCTIONS AND WARNINGS  
BEFORE OPERATING THIS LIFTER***



**DESIGNED FOR THE MATERIALS HANDLING PROFESSIONAL**



# TABLE OF CONTENTS

---

<b>TABLE OF CONTENTS</b> .....	<b>1</b>
<b>SPECIFICATIONS</b> .....	<b>3</b>
<b>WARNINGS</b> .....	<b>4</b>
<b>OPERATING FEATURES</b> .....	<b>5</b>
<b>ASSEMBLY</b> .....	<b>6</b>
<b>INTENDED USE</b> .....	<b>8</b>
<b>LOAD CHARACTERISTICS</b> .....	<b>8</b>
<b>OPERATING ENVIRONMENT</b> .....	<b>9</b>
<b>DISPOSAL OF THE LIFTER</b> .....	<b>9</b>
<b>OPERATION</b> .....	<b>10</b>
<b>BEFORE USING THE LIFTER</b> .....	<b>10</b>
Taking Safety Precautions .....	10
Performing Inspections and Tests .....	10
<b>TO USE PAD SHUTOFFS</b> .....	<b>11</b>
<b>TO APPLY THE PADS TO A LOAD</b> .....	<b>11</b>
Powering up the Lifter.....	11
Positioning the Lifter on the Load .....	12
Sealing the Pads against the Load.....	12
Reading the Vacuum Gauge .....	12
Vacuum Level on Optimal Surfaces .....	13
Vacuum Level on Other Surfaces .....	13
<b>TO LIFT AND MOVE THE LOAD</b> .....	<b>14</b>
Load Capacity and the Vacuum Gauge .....	14
Monitoring the Vacuum Gauge.....	14
Controlling the Lifter and Load.....	15
In Case of Power Failure .....	15
<b>TO TILT THE LOAD</b> .....	<b>15</b>
<b>TO RELEASE THE PADS FROM THE LOAD</b> .....	<b>16</b>
About Standby Mode.....	16
<b>AFTER USING THE LIFTER</b> .....	<b>16</b>
Storing the Lifter.....	16
<b>MAINTENANCE</b> .....	<b>17</b>
<b>INSPECTION SCHEDULE</b> .....	<b>17</b>
Every-Lift Inspection .....	17
Frequent Inspection.....	17
Periodic Inspection .....	17
Infrequent Use .....	18

<b>TESTING SCHEDULE .....</b>	<b>18</b>
Operational Tests.....	18
Load Test .....	18
<b>MAINTENANCE SCHEDULE .....</b>	<b>19</b>
<b>VACUUM PAD MAINTENANCE.....</b>	<b>19</b>
Friction Coefficient .....	19
Inspection .....	19
Cleaning.....	20
<b>VACUUM TEST .....</b>	<b>20</b>
<b>TILT COMPONENTS MAINTENANCE .....</b>	<b>21</b>
Tilt Actuator.....	21
Tilt Speed Valves .....	21
Tilt Stop Valves.....	21
Tilt Master Valve .....	21
<b>PAD MOUNT MAINTENANCE .....</b>	<b>22</b>
Clamp Inspection .....	22
Clamp Adjustment.....	22
<b>TO REPLACE SEALING RING INSERT IN VACUUM PAD .....</b>	<b>22</b>
<b>AIR FILTER MAINTENANCE – LARGE .....</b>	<b>23</b>
Filter Function and Conditions Requiring Service .....	23
Filter Service Procedures .....	23
<b>AIR FILTER MAINTENANCE – SMALL .....</b>	<b>24</b>
Filter Function and Conditions Requiring Service .....	24
Filter Service Procedures .....	24
<b>REPLACEMENT PARTS LIST .....</b>	<b>25</b>
<b>LIMITED WARRANTY.....</b>	<b>26</b>

# SPECIFICATIONS

---

<b>Model Number:</b>	PT4FS10TAIR
<b>Description:</b>	Designed for use with a crane or other hoisting equipment, the PT4FS10TAIR lifter employs vacuum to hold a load for lifting, and it provides powered 90° tilt movement for load manipulation.
<b>Power Source:</b>	Compressed air, 80-150 psi [550-1035 kPa] line pressure, 4 SCFM [113 liters/minute] @ 80 psi [550 kPa]
<b>Vacuum Pads:</b>	Four 10" [25 cm] nominal diameter (Model VPFS10T), standard rubber, spring-mounted (1/4" [7 mm] travel), with #60 filter screen and closed-cell foam rings for applications on rough or textured surfaces.
<b>Pad Shutoffs:</b>	Manual valves control vacuum flow at adjacent pads.
<b>Pad Spread:</b>	(to outer edges)
<b>Minimum:</b>	19¾" x 49¾" [501 mm x 1263 mm]
<b>Maximum:</b>	19¾" x 86¼" [501 mm x 2197 mm]
<b>Load Capacity:</b>	(rated at 16" Hg [-54 kPa] on clean, smooth, nonporous flat surfaces <sup>1</sup> )
<b>Per-Pad:</b>	150 lbs [68 kg]
<b>Maximum:</b>	600 lbs [270 kg]
<b>Lifter Weight:</b>	153 lbs [70 kg]
<b>Tilt Capability:</b>	Powered, 90°, continuous-duty type with adjustable-flow valves to control tilt speed; Standard speed = approx. 8 seconds per tilt travel in one direction. <sup>2</sup>
<b>Vacuum Pump:</b>	Venturi type, 2.8 SCFM [79 liters/minute] nominal vacuum flow @ 80 psi [550 kPa]
<b>Vacuum Reserve Tank:</b>	Vacuum reservoir helps prevent immediate vacuum loss in case of power failure.
<b>Vacuum Gauge:</b>	Dial gauge indicates current vacuum level in positive inches of Hg and negative kPa.
<b>Options:</b>	See separate instructions about optional features.
<b>Operating Elevation:</b>	Maximum = 10,000 feet [3048 meters]
<b>Operating Temperatures:</b>	32° to 120° F [0° to 49° C]
<b>Service Life:</b>	This lifter is designed to have a service life of at least 20,000 lifting cycles, when used and maintained as intended. Vacuum pads, filter elements and other wear-out items are excluded; see MAINTENANCE and REPLACEMENT PARTS LIST for more information. For the DISPOSAL OF THE LIFTER after its service life, see INTENDED USE.
<b>ASME Standard BTH-1:</b>	Design Category "B", Service Class "0" (see <a href="http://www.wpg.com">www.wpg.com</a> for more information)
<b>Hose Routing Diagram:</b>	One or more hose routing diagrams are provided in the final section of this <i>INSTRUCTIONS</i> manual for reference when servicing the lifter or troubleshooting a deficiency.

---

**!!-CE-!!** Note: This symbol appears in the *INSTRUCTIONS* manual only when requirements of a CE Standard are *different* from requirements of other standards that also apply to this vacuum lifter. CE requirements are mandatory in geographical areas where CE Standards apply, but may be optional in other locations.

---

<sup>1</sup> Load Capacity is based on a friction coefficient of 1; see MAINTENANCE: VACUUM PAD MAINTENANCE: Friction Coefficient for additional information.

<sup>2</sup> If the tilt speed is unsatisfactory, it can be adjusted as directed under TILT COMPONENTS MAINTENANCE: Tilt Speed Valves (see MAINTENANCE).

# WARNINGS

---



Powr-Grip is pleased to offer the most reliable vacuum lifters available. Despite the high degree of security provided by this product, certain precautions must be observed to protect the operator and others.



**Always** wear personal protective equipment that is appropriate for the material being handled. Follow trade association guidelines.

**Always** operate the lifter under conditions approved for its design (see INTENDED USE: OPERATING ENVIRONMENT).

**Never** operate a lifter that is damaged, malfunctioning, or missing parts.

**Never** operate a lifter if the sealing edge of any vacuum pad is cut or otherwise damaged.

**Never** remove or obscure warning labels.

**Never** operate a lifter if the Load Capacity or any warning appears to be missing or obscured.

**Always** make certain the contact surfaces of the load and all vacuum pads are clean prior to applying the pads (see MAINTENANCE: VACUUM PAD MAINTENANCE).

**Never** exceed the Load Capacity or attempt to lift loads the lifter is not designed for (see INTENDED USE: LOAD CHARACTERISTICS).

**Never** attempt to lift cracked or broken glass with this lifter.

**Always** position the vacuum pads correctly on the load prior to lifting (see OPERATION: TO APPLY THE PADS TO A LOAD).

**Never** lift a load when any vacuum indicator shows inadequate vacuum.

**Never** touch the vacuum release controls during a lift. This may result in loss of vacuum and release of the load.

**Never** allow people to ride on the lifter or the load being lifted.

**Never** lift a load higher than necessary or leave suspended loads unattended.

**Never** lift a load over people.

**Always** keep other personnel far enough away from the lifter to avoid injury in the event of an unexpected load release.

**Always** place the power control in the inactive position and, when possible, disconnect the power source before opening any enclosure on the lifter. (Only applicable to powered lifters)

**Always** remember that modifications to the lifter may compromise its safety. Wood's Powr-Grip cannot be responsible for the safety of a lifter that has been modified by the customer. For consultation, contact Wood's Powr-Grip (see LIMITED WARRANTY).

# OPERATING FEATURES

Note: Components featured in the following instructions for assembling, operating or maintaining the vacuum lifter are underlined> on their first appearance in each section.

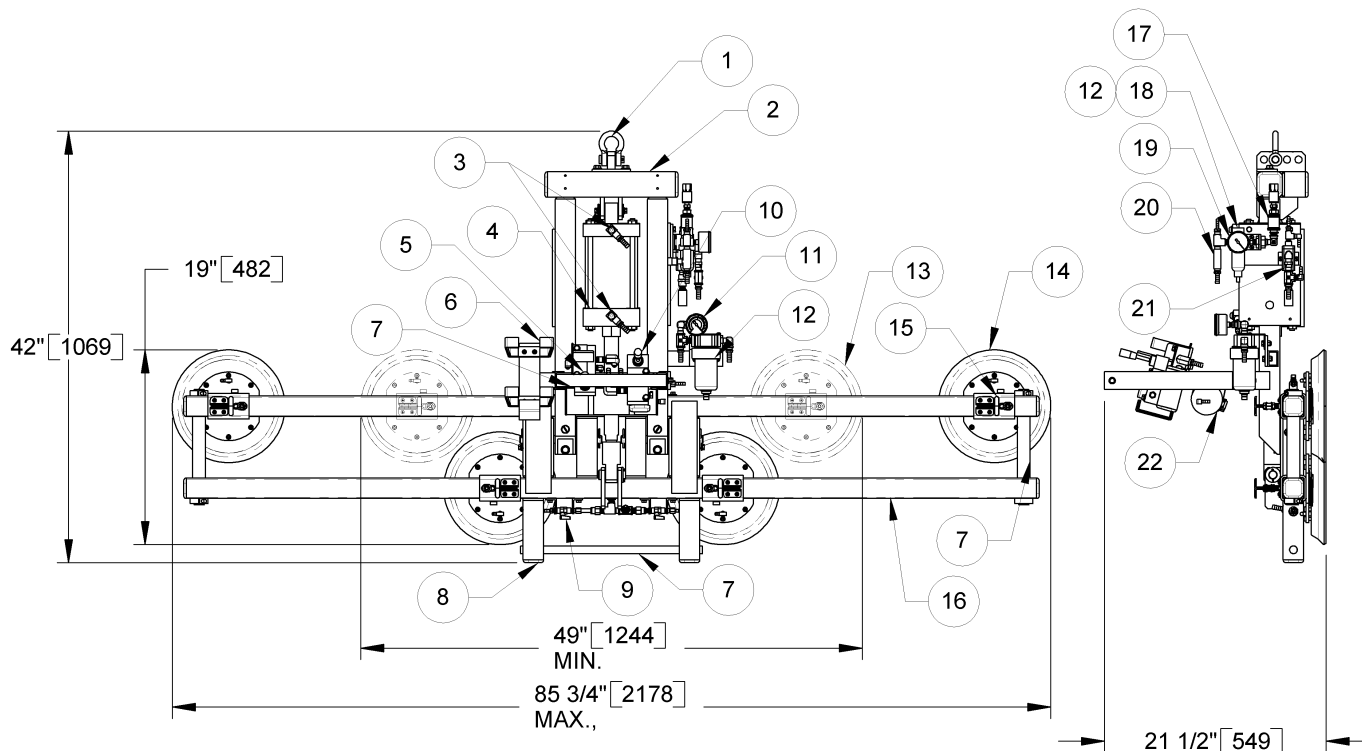

Standard PT4FS10TAIR shown.

- |                        |                                 |                           |
|------------------------|---------------------------------|---------------------------|
| 1 LIFT SHACKLE         | 8 PARKING FOOT                  | 16 PAD FRAME              |
| 2 LIFT BAR             | 9 PAD SHUTOFF                   | 17 AIR SUPPLY VALVE       |
| 3 TILT SPEED VALVES    | 10 TILT CONTROL VALVE           | 18 AIR PRESSURE REGULATOR |
| 4 TILT ACTUATOR        | 11 VACUUM GAUGE                 | 19 PRESSURE GAUGE         |
| 5 VACUUM CONTROL VALVE | 12 AIR FILTERS                  | 20 TILT MASTER VALVE      |
| 6 HOIST PENDANT BASKET | 13 ALTERNATIVE PAD LOCATION     | 21 VACUUM PUMP (VENTURI)  |
| 7 CONTROL HANDLE       | 14 VACUUM PAD                   | 22 VACUUM RESERVE TANK    |
|                        | 15 SLIDING ADJUSTABLE PAD MOUNT |                           |

# ASSEMBLY

---

1) Open the shipping container and remove all materials for restraining or protecting the vacuum lifter. Save the container for use whenever the lifter is transported.

2) Connect the lifter to an appropriate compressed air supply (see SPECIFICATIONS: Power Source), as follows:

Install the female quick connector (supplied) on the compressed air line. Connect the female quick connector to the male quick connector leading directly to the air supply valve.

Adjust the air pressure regulator to supply an air pressure of 60 to 80 psi [415 to 550 kPa]: Place the slide on the air supply valve in the "on" (I) position, to engage the compressed air supply. Then pull up the adjustment collar on the top of the regulator, and turn the collar clockwise to increase pressure or counter-clockwise to reduce pressure, as registered on the pressure gauge. When the desired adjustment is obtained, push down the collar to lock it in place.

Make certain the air line is routed so that it does not become tangled, kinked, pinched or cut while operating the lifter or hoisting equipment (see step 5).

Note: Place the slide on the air supply valve in the "off" (O) position when the lifter is not in use; otherwise, the vacuum pump would continue to consume air, causing the air compressor to cycle continually.

3) Select the location for the lift shackle: The lift shackle may be attached in any of 4 locations on the lift bar, which are provided to optimize the hang angle of the lifter and load. Make sure the lift shackle is secured by its restraining bolt.

4) Suspend the lifter from a crane as follows: Select hoisting equipment (crane and hoist, when applicable) rated to carry the maximum load weight plus the lifter weight (see SPECIFICATIONS: Maximum Load Capacity and Lifter Weight).

Note: Any application of the lifter must conform to all statutory or regulatory standards that relate to the hoisting equipment when used in its geographical location (eg, relevant OSHA standards in the USA).

If the lift bar of the lifter is resting in a horizontal orientation, raise it to a vertical orientation: Engage the tilt actuator as though tilting a load to the flat position (see OPERATION: To TILT THE LOAD); at the same time, manually lift on the lift bar to assist the actuator's movement. Then attach the hoisting equipment hook to the lift shackle.

 **WARNING: Hoisting equipment hook must be fitted with restraining latch to prevent lift shackle from slipping off under any circumstances.**

Note: Some hoisting equipment hooks could interfere with an upright load that extends beyond the lifter's pad frame. If the load would contact the hook during lifter operation, the operator must prevent this by attaching a sling (or other rigging that does not interfere with the load) between the hook and the lift shackle.

 **WARNING: Any sling used must be rated to carry maximum load weight plus lifter weight.**



Use the hoisting equipment to raise the lifter out of the shipping container. The control pendant for the hoisting equipment can be attached to the lifter by inserting it into the hoist pendant basket provided. Be careful to avoid damaging any vacuum pads. Remove the pad covers and save them for use whenever the lifter is stored. Now the lifter is operational.

- 5) Perform Operational and Load Tests for the lifter as directed in MAINTENANCE: TESTING SCHEDULE.

# INTENDED USE

---

## LOAD CHARACTERISTICS

 **WARNING:** *This lifter is NOT intended for lifting hazardous materials, such as explosives or radioactive substances.*

The operator must verify that the lifter is intended to handle each load, in accordance with the following requirements:

- The load must not exceed the maximum allowable weight specified under Load Capacity (see SPECIFICATIONS).
- The load must be a single piece of nonporous or semiporous material with a flat and relatively smooth contact surface.<sup>3</sup> To determine whether the load is too porous or rough, perform the test under Vacuum Level on Other Surfaces (see OPERATION: TO APPLY THE PADS TO A LOAD).
- The load's contact surface must be suitable for obtaining a friction coefficient of 1 with the lifter's vacuum pads (see MAINTENANCE: VACUUM PAD MAINTENANCE: Friction Coefficient), as verified by a friction test. If necessary, contact Wood's Powr-Grip for help in conducting a friction test.
- In order to avoid damaging the vacuum pads, the load's surface temperature must not exceed the allowable Operating Temperatures (see SPECIFICATIONS). However, if such an application cannot be avoided, Wood's Powr-Grip does offer a heat-resistant rubber compound and other solutions which may enable you to lift loads with higher surface temperatures. Contact Wood's Powr-Grip or an authorized dealer for more information.
- While the *minimum* length and width of the load are determined by the Pad Spread (see SPECIFICATIONS), the *maximum* length and width are determined by the allowable overhang, or the amount of load material that can extend sideways beyond the vacuum pads without breaking or otherwise being damaged.

The allowable overhang depends on the kind of load material being lifted, the thickness of the material, and the angle at which it is handled (if any). Since materials such as glass, stone or sheet metal each have different physical properties, the allowable overhang must be evaluated separately for each type of load. If necessary, contact Wood's Powr-Grip or an authorized dealer for help in determining the recommended overhang in a specific situation.

- 1-3/16" [3 cm] is the maximum allowable thickness of loads at the maximum weight (see SPECIFICATIONS: Load Capacity).<sup>4</sup> However, allowable thickness increases as load weight decreases. If necessary, contact Wood's Powr-Grip for help in determining the maximum thickness permitted when handling any specific load.

Note: Vacuum pads can stain or deform load surfaces with light colors or soft coatings. The operator should test such surfaces for detrimental effects before using the lifter on them.

---

<sup>3</sup> Lifters that feature concave vacuum pads can also attach to some kinds of curved loads. Since curvature affects the lifting capacity, contact Wood's Powr-Grip for help in determining the Load Capacity for a particular curved load.

<sup>4</sup> This thickness is also known as "1-1/4 inch" in the American stone industry.

## OPERATING ENVIRONMENT

The operator must determine whether the lifter is intended to be used in each work environment, in accordance with the following restrictions:

 **WARNING: Never use lifter in dangerous environments.**

- This lifter is not intended for use in any environment that is inherently dangerous to the operator or likely to compromise the lifter's ability to function. Environments containing explosives, caustic chemicals and other dangerous substances must be avoided when using the lifter.
- The lifter's work environment is limited by the Operating Elevation and Operating Temperatures indicated in SPECIFICATIONS.
- The lifter's work environment must be free of metal particles or any other contaminants that could damage lifter components through airborne contact or any other means of transmission in the environment. If such contaminants cause a vacuum pump failure, they could result in a load release and possible injury to the operator or others nearby.

 **WARNING: Environmental contaminants could result in vacuum pump failure.**

- Using the lifter in wet environments may require the operator to take special precautions: Moisture on contact surfaces of the load or vacuum pads diminishes the lifter's slip resistance, thereby reducing the lifting capacity (see MAINTENANCE: VACUUM PAD MAINTENANCE: Friction Coefficient).

 **WARNING: Moisture reduces slip resistance of vacuum pads.**

Although the lifter's exterior surfaces can tolerate some exposure to water vapor, they are not designed to be water-tight. Submerging the lifter or using it in rain may damage lifter components; these and similar conditions must be avoided.

- 
- **!!-CE-!!** If the lifter is employed in a construction area, CE Standard EN 13155 requires the use of a secondary positive holding device, such as a sling system, designed to support the load in case of a vacuum system failure.

 **WARNING: Where CE Standards apply, secondary positive holding device is required for lifting loads in construction zones.**

---

## DISPOSAL OF THE LIFTER

After the vacuum lifter has reached the end of its service life, you must dispose of the lifter in compliance with all local codes and regulatory standards that are relevant for the geographical region.

# OPERATION

---

## BEFORE USING THE LIFTER

The operator must determine whether the lifter is capable of performing each intended task, in accordance with the SPECIFICATIONS and INTENDED USE sections of this *INSTRUCTIONS* manual. In addition, all of the following preparations must be completed prior to lifting any load.

### Taking Safety Precautions

The operator must be trained in all relevant industry and regulatory standards for the operation of the vacuum lifter in its geographical location (eg, ASME B30.20 in the USA).

The operator must read and understand this *INSTRUCTIONS* manual, including all **WARNINGS**, before using the lifter. If necessary, contact Wood's Powr-Grip or an authorized dealer for assistance.

 **WARNING:** *Always wear appropriate personal protective equipment.*

The operator must wear any personal protective equipment and take any other precautions required to handle the load safely. Consult appropriate trade association guidelines to determine what precautions are necessary for each type of load material.

### Performing Inspections and Tests

Perform all inspections and tests required by the INSPECTION and TESTING SCHEDULES (see MAINTENANCE). In addition, if the lifter has been in storage, always conduct a VACUUM TEST before placing it in service (see MAINTENANCE).

**CAUTION:** *Examine each air filter regularly, and empty when necessary.*

The lifter is equipped with one or more air filters to help protect the vacuum system from contaminants. In order for a filter to function, the operator must empty the filter bowl before enough liquid accumulates to contact any portion of the filter element (see MAINTENANCE: AIR FILTER MAINTENANCE).

## TO USE PAD SHUTOFFS

Each shutoff on the pad frame controls the vacuum line to the adjacent vacuum pad. By activating or deactivating the vacuum flow at specific pads, the operator can use the lifter to handle loads of various weights and dimensions (see Load Capacity and Pad Spread in SPECIFICATIONS). In addition, certain pads may be deactivated in order to avoid holes in the load surface. To support the maximum load weight and larger load dimensions, all pads must be activated; for smaller weights and dimensions, some pads may be deactivated, ***provided that the lifter still has sufficient capacity to support the load*** (see INTENDED USE: LOAD CHARACTERISTICS).

**⚠ WARNING:** *Closing any pad shutoff reduces lifting capacity.*

To activate a pad, open the pad shutoff (place valve lever *parallel* with vacuum line); to deactivate a pad, close the pad shutoff (place valve lever *perpendicular* to vacuum line). To calculate the lifting capacity when some pads are deactivated, consult the Per-Pad Load Capacity rating (see SPECIFICATIONS) and multiply by the number of pads currently activated. Always activate pads in a symmetrical configuration, to keep the lifter balanced while lifting, and use as many pads as possible for each load being lifted, to maximize lifting capacity and to minimize load overhang.

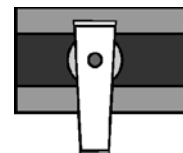

CLOSED  
PAD SHUTOFF VALVE

## TO APPLY THE PADS TO A LOAD

### Powering up the Lifter

Make sure the lever on the vacuum control valve is in the center position (see TO RELEASE THE PADS FROM THE LOAD: About Standby Mode to follow). Place the slide on the air supply valve in the "on" (☐) position, to engage the vacuum pump. The lifter is designed for the vacuum pump to run continuously.

**⚠ WARNING:** *Never place air supply valve in "off" position while operating lifter; keep pump running throughout lift.*

The air supply valve must remain in the "on" (☐) position while operating the lifter. Placing the air supply valve in the "off" (○) position during lifter operation could result in the release of the load and possible injury to the operator (see TO LIFT AND MOVE THE LOAD: In Case of Power Failure to follow).

## Positioning the Lifter on the Load

Make certain that the contact surfaces of the load and all vacuum pads are free of any contaminants that could prevent the pads from sealing against the load (see MAINTENANCE: VACUUM PAD MAINTENANCE). Center the lifter's pad frame to within 2" [5 cm] of the load center, since off-center loading can interfere with the lifter's tilt capability (see TO TILT THE LOAD to follow), and it may also damage the lifter.<sup>5</sup>

Arrange the sliding adjustable pad mounts to optimize load support and minimize load overhang while lifting (see INTENDED USE: LOAD CHARACTERISTICS): For each pad mount, release the clamp (pull outward on clamp handle), slide the pad mount to the desired location along the pad frame and re-engage the clamp (push inward firmly on clamp handle). Make sure that each pad mount is held in position securely by its clamp. If a clamp does not hold the pad mount securely, adjust the clamp as needed (see MAINTENANCE: Pad Mount Maintenance).

Generally it is desirable for the vacuum pads to be arranged symmetrically about the lift bar. Make sure that all activated pads will fit entirely on the load's contact surface (see SPECIFICATIONS: Pad Spread) and that they will be loaded evenly while lifting (see SPECIFICATIONS: Per-Pad Load Capacity). In addition, adjacent pads must not contact one another. After you have finished arranging the vacuum pads, position the lifter on the load so that all activated pads are touching the contact surface.

## Sealing the Pads against the Load

Move the lever on the vacuum control valve to the "apply" (↕) position: Pull outward on the lever's knob, move the lever all the way *upward* and release it. This position opens the lifter's vacuum lines to the airflow created by the vacuum pump, causing air to be drawn immediately at the vacuum pads.<sup>6</sup> Apply the lifter to the load until all activated pads seal against it.

**⚠ WARNING: Keep valve lever in "APPLY" position throughout lift.**

The valve lever must remain in the "apply" (↕) position throughout the entire lift. Any interruption of the vacuum flow during lifter operation could result in the release of the load and possible injury to the operator.

Note: If a vacuum pad has been lying against a hard object (as during shipping), it may be slightly distorted. Although initially it may be difficult to apply the pad to a load, this condition should correct itself with continued use.

## Reading the Vacuum Gauge

The vacuum gauge indicates the current vacuum level in the lifter's vacuum system. The *green* range indicates vacuum levels sufficient for lifting the maximum load weight, whereas the *red* range indicates vacuum levels that are *not* sufficient for lifting the maximum load weight. The gauge needle should show a sudden surge in vacuum as the vacuum pads seal against the load.

---

<sup>5</sup> The lifter is designed to handle the maximum load weight (see SPECIFICATIONS: Maximum Load Capacity) when the load's center of gravity is positioned within 2" [5 cm] of the pad frame's center point. Occasional loading deviations are permissible, provided that the operator can maintain control of the load at all times and that the load weight is low enough to avoid damaging the lifter.

<sup>6</sup> To minimize the time it takes for the lifter to attach and obtain full vacuum, do not place the valve lever in the "APPLY" position until the vacuum pads are contacting the load.

If it takes more than 5 seconds for the vacuum level to reach 5" Hg [-17 kPa], press on any activated pad that has not yet sealed.

## Vacuum Level on Optimal Surfaces

When the lifter is attached to clean, smooth, nonporous load surfaces, it should be able to maintain a vacuum level in the green range on the vacuum gauge, except when used at high elevations (see SPECIFICATIONS: Operating Elevation). If not, perform the VACUUM TEST (see MAINTENANCE) to determine whether there is a deficiency in the vacuum generating system.

## Vacuum Level on Other Surfaces

When the lifter is attached to contaminated, rough or porous load surfaces, it may not be able to maintain a vacuum level in the green range on the vacuum gauge, due to leakage in the seal between the vacuum pads and the load surface. In the case of contamination, thoroughly clean the contact surfaces of the load and the vacuum pads (see MAINTENANCE: VACUUM PAD MAINTENANCE: Cleaning), and reapply the lifter to the load. If the load has rough or porous surfaces, ***the operator must conduct a test to determine whether the lifter is designed to lift the load***, as follows:

- 1) Make sure the lifter's vacuum generating system is functioning correctly (see MAINTENANCE: VACUUM TEST).
- 2) Apply the vacuum pads to the load as previously directed.
- 3) When the vacuum level registers above 16" Hg [-54 kPa] on the vacuum gauge (see To LIFT AND MOVE THE LOAD: Load Capacity and the Vacuum Gauge to follow), disconnect the power source.
- 4) Raise the load a minimal distance, to assure that it is supported by the lifter.
- 5) Monitor the vacuum gauge while the load is suspended for 5 minutes: ***The lifter must maintain a minimum vacuum level of 10" Hg [-34 kPa] during this time.*** If not, the load does not possess the characteristics required for using this lifter.<sup>7</sup>

---

<sup>7</sup> Certain load materials are too rough or porous to allow the lifter to form a seal which can be maintained for 5 minutes without power. However, in geographical locations where CE Standards do not apply, it may be possible to use the lifter to lift such loads. Contact Wood's Powr-Grip for more information.

## TO LIFT AND MOVE THE LOAD

 **WARNING:** *Lift bar must be oriented vertically to lift load.*

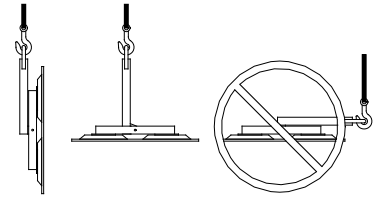

### Load Capacity and the Vacuum Gauge

The lifter's Load Capacity is rated at a vacuum level of 16" Hg [-54 kPa] (see SPECIFICATIONS). Vacuum higher than this level registers in the green range on the vacuum gauge, to indicate that the lifter is ready to lift the maximum load weight.

 **WARNING:** *Never attempt to lift load unless vacuum level registers higher than 16" Hg [-54 kPa].*

Do not attempt to lift the load while vacuum registers lower than 16" Hg [-54 kPa]; such an attempt could result in a load release and possible injury to the operator.

### Monitoring the Vacuum Gauge

The vacuum gauge must remain completely visible to the operator, so that it can be monitored throughout the entire lift.

 **WARNING:** *Vacuum gauge must be visible to operator throughout entire lift.*

The lifter's vacuum pump runs continuously to maintain sufficient vacuum for lifting the maximum load weight. If the vacuum system experiences leakage while the lifter is attached to the load, the vacuum gauge signals the reduction in vacuum to the operator. Make sure the vacuum gauge shows a vacuum level of 16" Hg [-54 kPa] or higher while you are lifting a load. If not, move away and stay clear of the load until it can be lowered to the ground or a stable support.

 **WARNING:** *Stay clear of any suspended load while vacuum level is lower than 16" Hg [-54 kPa].*

Discontinue lifter use until the cause of the vacuum loss can be determined. If the vacuum level remains lower than 16" Hg [-54 kPa] when the lifter is attached to clean, smooth, nonporous materials, the leakage is likely to be in the vacuum system. In this event, perform the VACUUM TEST (see MAINTENANCE) and inspect the vacuum pads for damage (see MAINTENANCE: VACUUM PAD MAINTENANCE: Inspection). If the vacuum loss cannot be remedied immediately, perform inspection and maintenance as needed to identify and correct any deficiency before resuming normal operation of the lifter.



## Controlling the Lifter and Load

When the vacuum gauge shows that the lifter is ready, use the hoisting equipment to raise the lifter and load as needed to clear any obstacles in their path. Use the control handle to keep the lifter and load in the desired orientation while they are suspended from the crane. Once sufficient clearance is established, the load can be tilted as desired (see TO TILT THE LOAD to follow).

**⚠ WARNING:** *Never allow any pad shutoff to be opened or closed while lifting.*

Opening or closing a pad shutoff while the lifter is supporting a load could result in the release of the load and possible injury to the operator or others. The operator must take all appropriate measures to prevent any person or object from accidentally moving the lever of a pad shutoff during the lift.

## In Case of Power Failure

The lifter is equipped with a vacuum reserve tank, designed to maintain vacuum temporarily in case of a power failure.

**⚠ WARNING:** *Stay clear of any suspended load in the event of a power failure.*

Although the lifter is designed to support the load for at least 5 minutes without power, this depends on many factors, including the condition of the load and the lifter's vacuum system (see INTENDED USE: LOAD CHARACTERISTICS and MAINTENANCE: VACUUM PAD MAINTENANCE, VACUUM TEST). If a power failure occurs, keep all personnel clear of the suspended load until it can safely be placed on the ground or a stable support. Correct any deficiency before resuming normal operation of the lifter.

## TO TILT THE LOAD

**CAUTION:** *Make sure load is positioned correctly on lifter (see TO APPLY); unbalanced loads may damage lifter.*

Remember that the load requires more vertical space when tilted to the upright position, as well as more horizontal space when tilted to the flat position. Make sure there is sufficient clearance for the load to tilt without contacting the operator or any nearby objects. The tilt control valve controls the powered tilt motion: To tilt the load towards the flat position, push the lever on the control valve *upward*; to tilt the load towards the upright position, push the lever *downward*. Releasing the lever locks the load in any position within the 90° range of tilt movement.

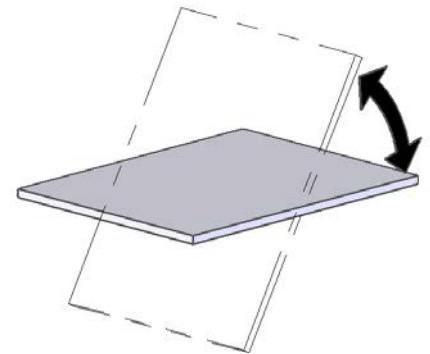

## TO RELEASE THE PADS FROM THE LOAD

 **WARNING:** *Load must be fully supported before releasing vacuum pads.*

When the load is at rest and fully supported, move the lever on the vacuum control valve to the "release" (☞) position: Pull outward on the lever's knob, move the lever all the way *downward* and then release it. This forces air into the vacuum pads, quickly breaking the vacuum seal. After the pads have disengaged completely from the load, move the lifter away. Then place the lifter in standby mode as directed in the following discussion.

### About Standby Mode

The lifter's vacuum control valve features a neutral position that reduces the amount of time required for the lifter to attach to a load and obtain full vacuum. To utilize this feature, pull outward on the lever's knob, move the lever to the *center* position and then release it. Placing the valve lever in the center position closes off the vacuum line that connects the vacuum pads to the vacuum generating system, causing vacuum to build up in the line.

 **WARNING:** *Never move valve lever to center position while lifter is supporting load.*

Standby mode may only be used when the lifter is not supporting a load. The operator must never move the valve lever to the center position while the lifter is supporting a load, because this could result in a load release and possible injury to the operator.

## AFTER USING THE LIFTER

Place the slide on the air supply valve in the "off" (☐) position.

**CAUTION:** *Do not set the lifter against any surfaces which could soil or damage the vacuum pads.*

Built-in parking feet can be used to support an unloaded lifter when not suspended from a crane: Make sure the pad frame is oriented vertically with the parking feet at the bottom. Use the hoisting equipment to gently lower the lifter until the parking feet support its entire weight. Make sure the lifter leans securely against an appropriate support; then detach the hoisting equipment hook from the lift shackle.

If the lifter is transported to another location, use the original shipping container and secure the lifter so as to protect the vacuum pads and all other components from damage while in transit.

### Storing the Lifter

Use the covers supplied to keep the vacuum pads clean.

.....  
**!!-CE-!!** In accordance with CE Standard EN 13155, the lifter is designed to rest on relatively horizontal surfaces without tipping over. To store the lifter in this way, set the lifter with the pads facing downward on a clean, smooth, flat surface. Then lower the lift bar to a horizontal orientation and place a support under the lift shackle.  
.....

# MAINTENANCE

---

 **WARNING:** *Make sure power source is disconnected before servicing lifter.*

Note: One or more wiring/hose routing diagrams may be provided in the final section of this *INSTRUCTIONS* manual for reference when servicing the lifter or trouble-shooting a deficiency.

## INSPECTION SCHEDULE

Perform inspections routinely, according to the following frequency schedule:

### Every-Lift Inspection

- Examine the vacuum pads and load surface for contamination or debris (see VACUUM PAD MAINTENANCE to follow).
- Examine the vacuum pads, controls and indicators for visual damage (see VACUUM PAD MAINTENANCE to follow).

If any deficiency is detected during the inspection, correct it before using the lifter and perform the Frequent Inspection to follow.

### Frequent Inspection

*(following every 20-40 hours' use; or whenever lifter is out of service for 1 month or more)*

- Examine the lifter's structure for visual damage.
- Examine the vacuum system (including vacuum pads, fittings and hoses) for visual damage.
- Examine the air filter for conditions requiring service (see AIR FILTER MAINTENANCE to follow).
- Perform the VACUUM TEST to follow.
- Check for unusual vibrations or noises while operating the lifter.

If any deficiency is detected during the inspection, correct it before using the lifter and perform the Periodic Inspection to follow.

### Periodic Inspection

*(following every 250-500 hours' use; or whenever lifter is out of service for 1 year or more)*

- Examine the entire lifter for external evidence of looseness, excessive wear, deformation, cracks, excessive corrosion, dents to structural or functional components, cuts, or any deficiency which might constitute a hazard.
- If the lifter runs on AC electrical power, inspect all parts of the electrical system for damage, wear or contamination that could constitute a hazard, in compliance with all local codes and regulatory standards that are relevant for the geographical region.

**CAUTION:** *Be sure to use appropriate cleaning methods for each type of electrical component, as specified by codes and standards. Improper cleaning can damage components.*

- Keep a written record of all Periodic Inspections.

If any deficiency is detected during the inspection, correct it before using the lifter. If necessary, return the lifter to Wood's Powr-Grip or an authorized dealer for repair (see LIMITED WARRANTY).

## Infrequent Use

If a lifter is used less than 1 day in a 2-week period, perform the Periodic Inspection *each time before using the lifter*.

## TESTING SCHEDULE

Perform these tests when placing the lifter in service *initially* and *each time following a repair or modification*. Correct any deficiency and retest before using the lifter.

### Operational Tests

- Perform the VACUUM TEST to follow.
- Test all features and functions of the lifter (see OPERATING FEATURES, OPERATION and MAINTENANCE).

### Load Test

Prove that the lifter can lift 100% of its Maximum Load Capacity (see SPECIFICATIONS), using an actual load or an equivalent simulation.<sup>8</sup> Employ the following method to test with an actual load:

- 1) Place a test load with appropriate LOAD CHARACTERISTICS (see INTENDED USE) on a stable support. Make sure the load is oriented in the upright position.<sup>9</sup>
- 2) Apply the vacuum pads to the load as previously directed.
- 3) When the vacuum level registers above 16" Hg [-54 kPa] on the vacuum gauge, turn off or disconnect the power source (as appropriate).
- 4) Raise the load a minimal distance, to assure that it is supported by the lifter.
- 5) Hold the load for 5 minutes. The load must not slip or fall during this time period. If it does, conduct a VACUUM TEST and inspect each vacuum pad as indicated under VACUUM PAD MAINTENANCE: Inspection (see sections to follow). Correct any deficiency that is found and retest the lifter.

Note: See MAINTENANCE topics to follow for additional directions about inspecting and testing specific lifter components.

---

<sup>8</sup> ASME Standard B30.20 requires the lifter to be tested to 125% of its Load Capacity.

<sup>9</sup> Flat Lifters are exempt from this requirement.

# MAINTENANCE SCHEDULE

Unless specified elsewhere in this *INSTRUCTIONS* manual, the lifter does not require maintenance on a routine basis. Instead, maintenance must be performed whenever a deficiency is indicated by routine inspections or tests. Any maintenance warranted must be performed before resuming normal operation of the lifter.

## VACUUM PAD MAINTENANCE

### Friction Coefficient

The friction coefficient represents the lifter's ability to resist load slippage when the load is oriented in any position except horizontal. If the contact surfaces of either the load or the vacuum pads are not clean, dry and in good condition, slippage is more likely to occur.

The Load Capacity of most Powr-Grip lifters is based on a friction coefficient of 1 (only Flat Lifters are exempt from this requirement). However, a vacuum pad's ability to maintain this friction coefficient is reduced by factors such as contamination, wear, age and exposure to sunlight, as well as the condition of the load's contact surface (see INTENDED USE: LOAD CHARACTERISTICS). Pads that have surface contamination must be thoroughly cleaned (see Cleaning discussion to follow). Over time, the rubber in a pad may experience hardening or leaching of chemicals, resulting in stiffness or surface glaze. Pads that exhibit wear, stiffness or glaze must be replaced.

In addition, all pads should be replaced on a regular basis, preferably after no more than 2 years, to ensure that the friction coefficient is not compromised. If necessary, contact your dealer or Wood's Powr-Grip for more information.

### Inspection

Inspect each vacuum pad for the following deficiencies routinely, as directed in the preceding INSPECTION and TESTING SCHEDULES. Correct any deficiency before using the lifter.

- Contaminates on the pad face or sealing edges: Soil build-up can prevent pads from sealing adequately or reduce the friction coefficient (see discussion preceding). Follow the directions to clean pads as necessary (see discussion to follow).
- Filter screen missing from pad face: This screen helps prevent debris from plugging the vacuum hose and the air filter. Replace any missing screen immediately (see REPLACEMENT PARTS LIST).
- Nicks, cuts or abrasions in sealing edges: Pad damage can reduce the lifting capacity of the lifter. Replace any damaged pad immediately (see REPLACEMENT PARTS LIST).<sup>10</sup>

 **WARNING:** *Replace vacuum pad if sealing edge has any nicks, cuts or abrasions.*

- Wear, stiffness or glaze: See Friction Coefficient preceding. Replace any pad that exhibits wear, stiffness or glaze (see REPLACEMENT PARTS LIST).

---

<sup>10</sup> If the lifter is equipped with VPFS10T or VPFS625 pads, the sealing edge is the replaceable sealing ring. When it is damaged, see TO REPLACE SEALING RING INSERT IN VACUUM PAD to follow.

## Cleaning

Regularly clean the face of each vacuum pad to remove oil, dust and any other contaminants. Acceptable cleaning agents include soapy water and other mild cleansers. Do *not* use solvents, petroleum-based products (including kerosene, gasoline and diesel fuel) or any harsh chemicals for cleaning. Do *not* use unauthorized rubber cleaners or conditioners, such as those intended for cleaning tires or vinyl surfaces, because those products can leave a hazardous film on vacuum pads which significantly reduces their lifting capacity (see Friction Coefficient preceding). The use of any unauthorized cleaning agent is prohibited because it could damage the pad and/or create a hazard to the operator or others.

 **WARNING:** *Never use solvents, gasoline or other harsh chemicals to clean vacuum pad.*

 **WARNING:** *Never use unauthorized rubber cleaners or conditioners to clean vacuum pad.*

To prevent liquid from contaminating the vacuum system during cleaning, cover the suction hole in the recess for the filter screen or make sure the pad faces downward. Use a clean sponge or lint-free cloth to apply an authorized cleanser and wipe the pad face clean. A toothbrush (or similar brush with bristles *that do not harm rubber*) may be used to remove contaminants clinging to sealing edges.<sup>11</sup> Wipe all residue from the pad face, and allow the pad to dry completely before using the lifter.

## VACUUM TEST

Test the vacuum system for leakage routinely, as directed in the preceding INSPECTION and TESTING SCHEDULES.

- 1) Clean the face of each vacuum pad as previously directed (see VACUUM PAD MAINTENANCE: Cleaning).
- 2) Apply the lifter to a clean, smooth, nonporous surface. The surface should be flat or possess no more curvature than the lifter is designed for (if any).<sup>12</sup>
- 3) When the vacuum level registers above 16" Hg [-54 kPa] on the vacuum gauge, turn off or disconnect the power source (as appropriate) and leave the pads attached to the surface.
- 4) Monitor the vacuum gauge: *The vacuum level should not decrease by more than 4" Hg [-14 kPa] in 10 minutes.*

 **WARNING:** *If lifter fails vacuum test, discontinue use immediately.*

Correct any deficiency in the vacuum system before using the lifter. Contact Wood's Powr-Grip or an authorized dealer for assistance.

---

<sup>11</sup> If these cleaning methods are not successful, contact Wood's Powr-Grip or an authorized dealer for assistance.

<sup>12</sup> Any test material used must be fully and independently supported, and capable of bearing the lifter's weight. Do not use the lifter to lift the test material during the vacuum test.

# TILT COMPONENTS MAINTENANCE

## Tilt Actuator

Tilt motion is accomplished using an air-powered linear actuator. Since the tilt actuator is prelubricated, no additional lubrication is required under normal circumstances. The tilt actuator is equipped with several adjustable features that are set at the factory and should not need readjustment. However, in the event that adjustments are required, proceed as follows:

## Tilt Speed Valves

The tilt speed valves located at each end of the tilt actuator control the speed of actuator movement. Speed is adjusted independently for each direction of the actuator's stroke, using an adjustment screw located at the outside end of each speed valve, as follows:

- 1) Determine which direction of the stroke requires a speed adjustment, and identify the speed valve governing speed in that direction: The speed valve at the *upper* end of the actuator controls *retraction* (load movement from upright to flat), whereas the speed valve at the *lower* end of the actuator controls *extension* (load movement from flat to upright).
- 2) Determine which direction to turn the valve's adjustment screw in order to produce the desired stroke speed: To *reduce* the speed of the stroke, turn the adjustment screw *clockwise*. To *increase* the speed of the stroke, turn the adjustment screw *counter-clockwise*.

Note: The standard setting for the *upper* speed valve is 2-1/2 turns counter-clockwise from full clockwise, and the standard setting for the *lower* speed valve is 2-1/4 turns counter-clockwise from full clockwise.

- 3) Check the stroke speed and repeat steps 1-2 as necessary to obtain the desired adjustment.

## Tilt Stop Valves

Tilt stop valves are integrated in the ends of the tilt actuator to control the cushioning effect at each end of the stroke. An adjustment screw is flush-mounted on the side of the actuator *directly opposite* from each tilt speed valve, in order to adjust the cushioning effect, as follows:

- 1) Determine which end of the stroke needs to be adjusted, and identify the adjustment screw governing the cushioning effect at that end: The *upper* screw controls the end of the *retraction* stroke, whereas the *lower* screw controls the end of the *extension* stroke.
- 2) Determine which direction to turn the adjustment screw in order to produce the desired cushioning effect: To *increase* the cushioning effect, turn the adjustment screw *clockwise*. To *reduce* the cushioning effect, turn the adjustment screw *counter-clockwise*.

Note: The standard setting for both *upper* and *lower* adjustment screws is 2 turns counter-clockwise from full clockwise.

- 3) Check the cushioning effect and repeat steps 1-2 as necessary to obtain the desired adjustment.

## Tilt Master Valve

The tilt master valve controls airflow to the tilt actuator, in order to set the maximum stroke speed in both directions. This prevents the lifter or load from being damaged if anyone attempts to tilt the lifter when the actuator is not completely pressurized. Such a condition may exist after shipping or storing the lifter, or if the tilt control valve is operated while the air supply valve is in the "off" (☐) position. **CAUTION: Do not adjust the tilt master valve unless there is clear indication it has come out of adjustment.** The standard setting for the master valve is 2 turns counter-clockwise from full clockwise, when viewed from the end of the adjustment knob. The master valve must remain at the standard setting and should not be adjusted, unless there is reason to believe that it has come out of adjustment.

# PAD MOUNT MAINTENANCE

## Clamp Inspection

For each sliding adjustable pad mount on the lifter, inspect the clamp for damage and worn parts. Make sure that the neoprene contact pad is not so worn that metal is exposed. Engage each clamp to make sure that the pad mount is held securely in place. Correct any deficiency before using the lifter. See the following section for adjustment instructions.

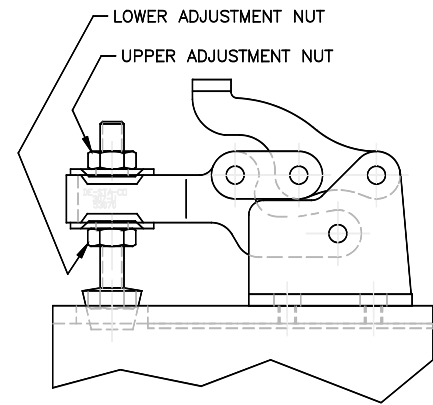

## Clamp Adjustment

In order to securely hold the sliding adjustable pad mount in position on the pad frame, the clamping force of the pad mount may require adjustment. To increase the clamping force, release the clamp, loosen the upper adjustment nut and tighten the lower adjustment nut. To reduce the clamping force, release the clamp, loosen the lower adjustment nut and tighten the upper adjustment nut. Adjustments in 1 revolution increments are recommended. After making an adjustment, slowly engage the clamp, making sure that the neoprene contact pad fits freely through the hole in the pad mount tube. Once the clamp is engaged, make sure the clamp holds the pad mount securely in place. Be sure to verify the clamp adjustments before resuming normal operation of the lifter.

## TO REPLACE SEALING RING INSERT IN VACUUM PAD

- 1) Remove the old sealing ring insert: Hold the vacuum pad firmly and pull the ring insert out from the mounting groove. Discard any damaged ring insert.
- 2) Install a new sealing ring insert (see REPLACEMENT PARTS LIST): Make sure the entire vacuum pad is clean, including the mounting groove (see Vacuum Pad Maintenance: Pad Cleaning preceding). Push the ring insert into the mounting groove so that the insert's base (flat side) fits flush against the bottom of the groove. Begin by placing the inside edge of the ring insert against the inside edge of the mounting groove. Then push gently and firmly on the outside edge of the ring insert until it seats completely into the mounting groove. A pad ring installation tool is available to facilitate this process (see REPLACEMENT PARTS LIST). Work your way around the entire ring insert, repeating this process until the entire ring is seated in the mounting groove.
- 3) Make sure that the sealing ring is secure and fully inserted into the mounting groove around the entire perimeter of the vacuum pad.

Note: If the ring insert ever comes partially or entirely out of the mounting groove, inspect the ring insert for damage and reinstall an undamaged ring insert according to preceding directions.



# AIR FILTER MAINTENANCE — LARGE

(for 4.4 oz [130 ml] bowl size filters)

## Filter Function and Conditions Requiring Service

An air filter prevents solid particles and liquid from contaminating components in the vacuum system.

**CAUTION:** *Examine air filter regularly and empty when necessary.*

Liquid must not contact any portion of the filter element; remove trapped liquid regularly. Replace the element if it has an overall dirty appearance, or if there is a noticeable increase in the time required to attain full vacuum. (Refer to REPLACEMENT PARTS LIST for filter element kit.)

## Filter Service Procedures

1) Unscrew the threaded collar (8) from the body (1). Support the body while twisting the collar, to protect the vacuum line fittings from being damaged. Then remove the bowl guard (7) and the bowl (6).

2) Determine whether the filter element (3) needs to be replaced (see Conditions Requiring Service preceding). *If so*, proceed to step 3.

*If not*, remove any liquid or contaminants from the bowl; clean the old bowl seal (5) with mild soap and water; and skip to step 7.

3) Unscrew the baffle (4), and remove the element and deflector (2).

4) Discard the element and the bowl seal (5).

5) Clean all internal parts and the bowl, using mild soap and water only. *Do not* use any other cleaners.

6) Install the deflector and a new filter element; then screw the baffle back on (tighten gently, finger tight) to hold the element in place.

7) Lubricate the new or cleaned bowl seal, using a mineral base oil or grease (such as the lubricant furnished in the filter element kit). *Do not* use synthetic oils, such as esters, or silicones.

8) Place the bowl seal around the rim of the bowl. Then install the bowl on the body, taking care to avoid contaminating the filter element with lubricant.

9) Install the bowl guard and the collar, tightening it only hand-tight (28-32 in-lbs [316-362 N-cm] torque).

10) Test the vacuum system to be certain the air filter does not leak (see VACUUM TEST preceding, if applicable).

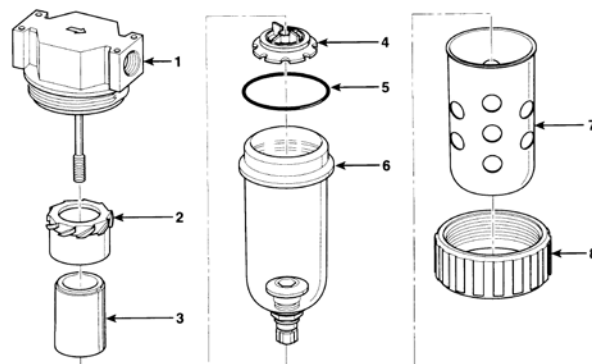

**⚠ WARNING:** When the air filter is being used on a *vacuum* system, rather than with pressure, using the twist drain to remove liquid from the bowl is *not* recommended. *Never* disturb the twist drain, as contaminants could lodge in the drain seal and cause a vacuum leak

# AIR FILTER MAINTENANCE – SMALL

(for 1 oz [30 ml] bowl size filters)

## Filter Function and Conditions Requiring Service

An air filter prevents solid particles and liquid from contaminating components in the vacuum system.

**CAUTION:** *Examine air filter regularly and empty when necessary.*

Liquid must not contact any portion of the filter element; remove trapped liquid regularly. Replace the element if it has an overall dirty appearance, or if there is a noticeable increase in the time required to attain full vacuum. (Refer to REPLACEMENT PARTS LIST for filter element kit.)

## Filter Service Procedures

- 1) Unscrew the bowl (6) from the body (1). Support the body while twisting the bowl, to protect the vacuum line fittings from being damaged.
- 2) Determine whether the filter element (4) needs to be replaced (see Conditions Requiring Service preceding). *If so*, proceed to step 3.  
*If not*, remove any liquid or contaminants from the bowl; clean the old bowl seal (2) with mild soap and water; and skip to step 7.
- 3) Unscrew the element holder (5) and remove all internal parts.
- 4) Set aside the element, element gaskets (7) and bowl seal for disposal later.
- 5) Clean all other internal parts and the bowl, using mild soap and water only. *Do not* use any other cleansing agents.
- 6) Place the new element gaskets and element, along with the old deflector (3), on the element holder, and screw the assembly back into the filter body (tighten gently, finger tight).
- 7) Lubricate the new or cleaned bowl seal (2)<sup>13</sup>, using a mineral base oil or grease (such as the lubricant furnished in the filter element kit). *Do not* use synthetic oils, such as esters, and *do not* use silicones.
- 8) Place the bowl seal around the rim of the bowl. Then screw the bowl back into the body, taking care to avoid contaminating the filter element with lubricant. Hand-tighten only.
- 9) Test the vacuum system to be certain the air filter does not leak (see VACUUM TEST preceding, if applicable).

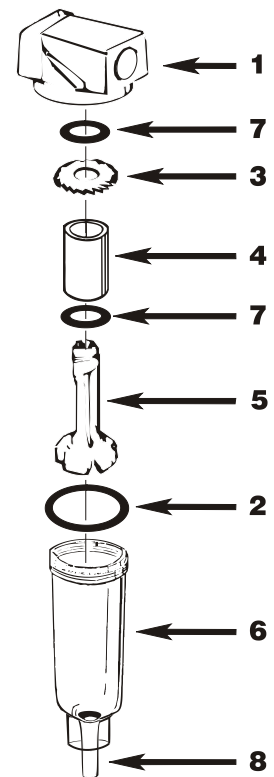

**⚠ WARNING:** When the air filter is being used on a *vacuum* system, rather than with pressure, using the twist drain (8) to remove liquid from the bowl is *not* recommended. **Never** disturb the twist drain, as contaminants could lodge in the drain seal and cause a vacuum leak.

<sup>13</sup> The filter element kit may contain two sizes of bowl seals (O-ring type gaskets). If so, use the smaller bowl seal; or if in doubt, compare the old bowl seal to determine the appropriate size.

# REPLACEMENT PARTS LIST

Stock No.	Description	Qty.
93012	Pad Shutoff Valve	4
66161	Vacuum Pump - Venturi Type - 2.8 SCFM [79 liters/minute]	1
65443	Vacuum Hose - 3/8" [9.5 mm] ID (approx. 100" [254 cm] in length)	1
65440	Vacuum Hose - 1/4" [6.3 mm] ID - Red (approx. 24" [61 cm] in length)	1
65440AM	Vacuum Hose - 1/4" [6.3 mm] ID x 120" [305 cm] Length - Coiled	2
65436	Pressure Hose - 1/4" [6.3 mm] ID (approx. 42" [107 cm] in length)	1
65440	Vacuum Hose - 1/4" [6.3 mm] ID (approx. 36" [92 cm] in length)	1
65301	Foam - Handle Grip (approx. 12" [30 cm] in length)	1
65288	Air Supply Valve - Slide Type	1
65277	Vacuum Control Valve w/Lever	1
65273	Tilt Control Valve w/Lever	1
65268	Tilt Speed Valve	2
65265	Tilt Master Valve	1
65212	Check Valve - 1/4 NPT	1
65014	Pad Spring - Wave Type (for HV11 pads)	4
65010	Pad Spring - Coil Type (for VPFS10T pads)	4
53122	Pad Fitting - Elbow - 5/32" [4.0 mm] ID	4
49724TT	Sealing Ring Insert for VPFS10T Pad - Closed Cell Foam	4
49724RT	Sealing Ring Insert for VPFS10T Pad - Heat-Resistant Rubber	4
49724LT	Sealing Ring Insert for VPFS10T Pad - Low-Marking Rubber	4
49672T	Vacuum Pad - Model VPFS10T / 10" [25 cm] Diameter - w/Replaceable Sealing Ring	4
49605T	Vacuum Pad - Model HV11 / 10" [25 cm] Diameter - Lipped (option)	4
49144	End Plug - 2 1/2" x 2 1/2" x 3/16" [63.5 mm x 63.5 mm x 4.8 mm] Tubing Size	3
49122	End Plug - 2" x 2" x 1/4" [50.8 mm x 50.8 mm x 6.4 mm] Tubing Size	4
48003	Hold-Down Clamp (for pad mounts)	4
29353	Pad Cover	4
20050	Pad Ring Installation Tool	1
16134	Filter Element Kit (for 1 oz [30 ml] bowl size air filter/regulator)	1
16132	Filter Element Kit (for 4.4 oz [130 ml] bowl size air filter)	1
16042	Quick Connect - 1/4 MNPT - Male End	1
16040	Quick Connect - 1/4 FNPT - Female End	1
15972	Pressure Gauge - 1/8 NPT - CBM Type	1
15910	Vacuum Gauge - 1/8 NPT - CBM Type	1
15632	Pad Filter Screen - Small (for VPFS10T pads)	4
15630	Pad Filter Screen - Large (for HV11 pads)	4
10900	Shoulder Bolt - Socket Head - 5/16" x 1/2" x 1/4-20 Thread (for mounting pads)	24
--	Tilt Actuator - Air Cylinder Type	1

***SERVICE ONLY WITH IDENTICAL REPLACEMENT PARTS,  
AVAILABLE AT WPG.COM OR THROUGH AN AUTHORIZED WPG DEALER***

# LIMITED WARRANTY

---

Powr-Grip products are carefully constructed, thoroughly inspected at various stages of production, and individually tested. They are warranted to be free from defects in workmanship and materials for a period of one year from the date of purchase.

If a problem develops during the warranty period, follow the instructions hereafter to obtain warranty service. If inspection shows that the problem is due to defective workmanship or materials, Powr-Grip will repair the product without charge.

## ***WARRANTY DOES NOT APPLY WHEN:***

Modifications have been made to the product after leaving the factory.

Rubber portions have been cut or scratched during use.

Repairs are required due to abnormal wear and tear.

The product has been damaged, misused, or neglected.

If a problem is not covered under warranty, Powr-Grip will notify the customer of costs prior to repair. If the customer agrees to pay all repair costs and to receive the repaired product on a C.O.D. basis, Powr-Grip then will proceed with repairs.

## **TO OBTAIN REPAIRS OR WARRANTY SERVICE**

For purchases in *North America*:

Contact the Technical Service Department at Wood's Powr-Grip Co. When factory service is required, ship the complete product--prepaid--along with your name, address and phone number to the street address hereafter.

For purchases in *all other localities*:

Contact your dealer or the Technical Service Department at Wood's Powr-Grip Co. for assistance.

Wood's Powr-Grip Co., Inc.  
908 West Main St. / P.O. Box 368  
Laurel, MT USA 59044

phone 800-548-7341

phone 406-628-8231

fax 406-628-8354



