

KEEP FOR FUTURE REFERENCE



**P.O. Box 368 – 908 West Main
Laurel, MT USA 59044
phone 800-548-7341
phone 406-628-8231
fax 406-628-8354**

INSTRUCTIONS

International Version

MODEL NUMBERS: PFHS69AC, PFHL69AC,
PFV69AC, PFHS89AC, PFHL89AC

SERIAL NUMBER: _____
(please see serial label and record number here)

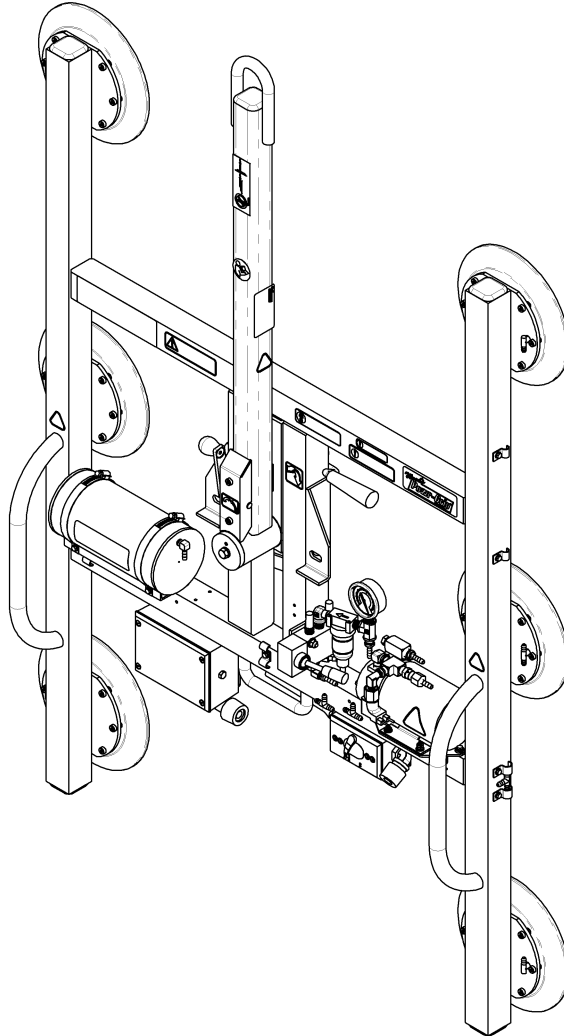

**POWR-FRAME
AC-VOLTAGE**



***READ ALL INSTRUCTIONS AND WARNINGS
BEFORE OPERATING THIS LIFTER***



DESIGNED FOR THE MATERIALS HANDLING PROFESSIONAL

TABLE OF CONTENTS

SPECIFICATIONS	3
WARNINGS	4
OPERATING FEATURES	5
ASSEMBLY	6
INTENDED USE	7
LOAD CHARACTERISTICS	7
OPERATING ENVIRONMENT	8
DISPOSAL OF THE LIFTER	8
OPERATION	9
BEFORE USING THE LIFTER	9
Taking Safety Precautions.....	9
Performing Inspections and Tests.....	9
TO APPLY THE PADS TO A LOAD	10
Powering up the Lifter	10
Positioning the Lifter on the Load	10
Sealing the Pads against the Load	10
Reading the Vacuum Gauge.....	11
Vacuum Level on Optimal Surfaces.....	11
Vacuum Level on Other Surfaces.....	11
TO LIFT AND MOVE THE LOAD	12
Positioning the Lift Bar	12
Load Capacity and the Vacuum Gauge.....	12
Monitoring the Vacuum Gauge	12
Controlling the Lifter and Load	12
In Case of Power Failure.....	13
TO ROTATE THE LOAD EDGEWISE	14
TO TILT THE LOAD	15
TO RELEASE THE PADS FROM THE LOAD	16
AFTER USING THE LIFTER	16
Storing the Lifter.....	16
MAINTENANCE	17
INSPECTION SCHEDULE	17
Every-Lift Inspection	17
Frequent Inspection	17
Periodic Inspection.....	17
Infrequent Use	18
TESTING SCHEDULE	18
Operational Tests.....	18
Load Test.....	18
MAINTENANCE SCHEDULE	19

VACUUM PAD MAINTENANCE..... 19
Friction Coefficient 19
Inspection 19
Cleaning..... 20

VACUUM TEST 20

AIR FILTER MAINTENANCE – SMALL 21
Filter Function and Conditions Requiring Service 21
Filter Service Procedures 21

VACUUM PUMP MAINTENANCE – GAST 3032 & 2032 22

REPLACEMENT PARTS LIST..... 23

LIMITED WARRANTY 24

SPECIFICATIONS

	6 Vacuum Pads	8 Vacuum Pads
Model Number:		
Vertical Configuration:	PFV69AC	--
Horizontal / Small Configuration:	PFHS69AC	PFHS89AC
Horizontal / Large Configuration:	PFHL69AC	PFHL89AC
Maximum Pad Spread: (to outer edges)		
Vertical Configuration:	57¼" x 46¼" [1451 x 1172 mm]	--
Horizontal / Small Configuration:	37¼" x 46¼" [943 x 1172 mm]	39¼" x 47¼" [994 x 1197 mm]
Horizontal / Large Configuration:	46¼" x 57¼" [1172 x 1451 mm]	39¼" x 59¼" [994 x 1502 mm]
Lifter Weight: (for larger configurations)	110 lbs [50 kg]	130 lbs [59 kg]
Load Capacity:	(rated at 16" Hg [-54 kPa] on clean, smooth, nonporous flat surfaces ¹)	
Per-Pad:	125 lbs [56.5 kg]	125 lbs [57 kg]
Maximum:	700 lbs [320 kg]	1000 lbs [455 kg]
Description:	Designed for use with a crane or other hoisting equipment, PF-9AC lifters employ vacuum to hold a load for lifting, and they provide manual 180° rotation and manual 90° tilt movements for load manipulation.	
Power Source:	See serial number plate for specific AC voltage, frequency and amperage.	
Vacuum Pads:	9" [23 cm] nominal diameter (Model VPFS9), standard rubber, spring-mounted (¼" [7 mm] travel), with #60 filter screen	
Rotation Capability:	Manual, 180°, with automatic locking at each ¼ revolution (when desired)	
Tilt Capability:	Manual, 90°, with automatic locking in vertical position	
Vacuum Pump:	Rotary vane type, 2.5 SCFM [71 liters/minute] nominal airflow	
Vacuum Reserve Tank:	Vacuum reservoir helps prevent immediate vacuum loss in case of power failure.	
Vacuum Gauge:	Dial gauge indicates current vacuum level in positive inches of Hg and negative kPa.	
Options:	See separate instructions about optional features.	
Operating Elevation:	Maximum = 8,000' [2,438 m]	
Operating Temperatures:	32° to 104° F [0° to 40° C]	
Service Life:	This lifter is designed to have a service life of 20,000 lifting cycles, when used and maintained as intended. Vacuum pads, filter elements and other wear-out items are excluded; see MAINTENANCE and REPLACEMENT PARTS LIST for more information. For the DISPOSAL OF THE LIFTER after its service life, see INTENDED USE.	
ASME Standard BTH-1:	Design Category "B", Service Class "0" (see www.wpg.com for more information)	

!!-CE-!! Note: This symbol appears in the *INSTRUCTIONS* manual only when requirements of a CE Standard are *different* from requirements of other standards that also apply to this vacuum lifter. CE requirements are mandatory in geographical areas where CE Standards apply, but may be optional in other locations.

¹ Load Capacity is based on a friction coefficient of 1; see MAINTENANCE: VACUUM PAD MAINTENANCE: Friction Coefficient for additional information.

WARNINGS



Powr-Grip is pleased to offer the most reliable vacuum lifters available. Despite the high degree of security provided by this product, certain precautions must be observed to protect the operator and others.



Always wear personal protective equipment that is appropriate for the material being handled. Follow trade association guidelines.

Always operate the lifter under conditions approved for its design (see INTENDED USE: OPERATING ENVIRONMENT).

Never operate a lifter that is damaged, malfunctioning, or missing parts.

Never operate a lifter if the sealing edge of any vacuum pad is cut or otherwise damaged.

Never remove or obscure warning labels.

Never operate a lifter if the Maximum Load Capacity or any warning appears to be missing or obscured.

Always make certain the contact surfaces of the load and all vacuum pads are clean prior to attaching the pads (see MAINTENANCE: VACUUM PAD MAINTENANCE).

Never exceed the Maximum Load Capacity or attempt to lift loads that the lifter is not designed for (see INTENDED USE: LOAD CHARACTERISTICS).

Never attempt to lift cracked or broken glass with this lifter.

Always position the vacuum pads correctly on the load prior to lifting (see OPERATION: To ATTACH THE PADS TO A LOAD).

Never lift a load when any vacuum indicator shows inadequate vacuum.

Never touch the vacuum release controls during a lift. This may result in loss of vacuum and release of the load.

Never allow people to ride on the lifter or the load being lifted.

Never lift a load higher than necessary or leave suspended loads unattended.

Never lift a load over people.

Always keep other personnel far enough away from the lifter to avoid injury in the event of an unexpected load release.

Always place the power control in the inactive position and, when possible, disconnect the power source before opening any enclosure on the lifter. (Only applicable to powered lifters)

Always remember that modifications to the lifter could compromise its safety. Wood's Powr-Grip cannot be responsible for the safety of a lifter that has been modified by others. For consultation, contact Wood's Powr-Grip (see LIMITED WARRANTY).

Never disengage both the rotation latch and the tilt latch at the same time.

Always employ a ground fault circuit interrupter when connecting the power cable to the power source.

OPERATING FEATURES

Note: Components featured in the following instructions for assembling, operating or maintaining the vacuum lifter are underlined> on their first appearance in each section.

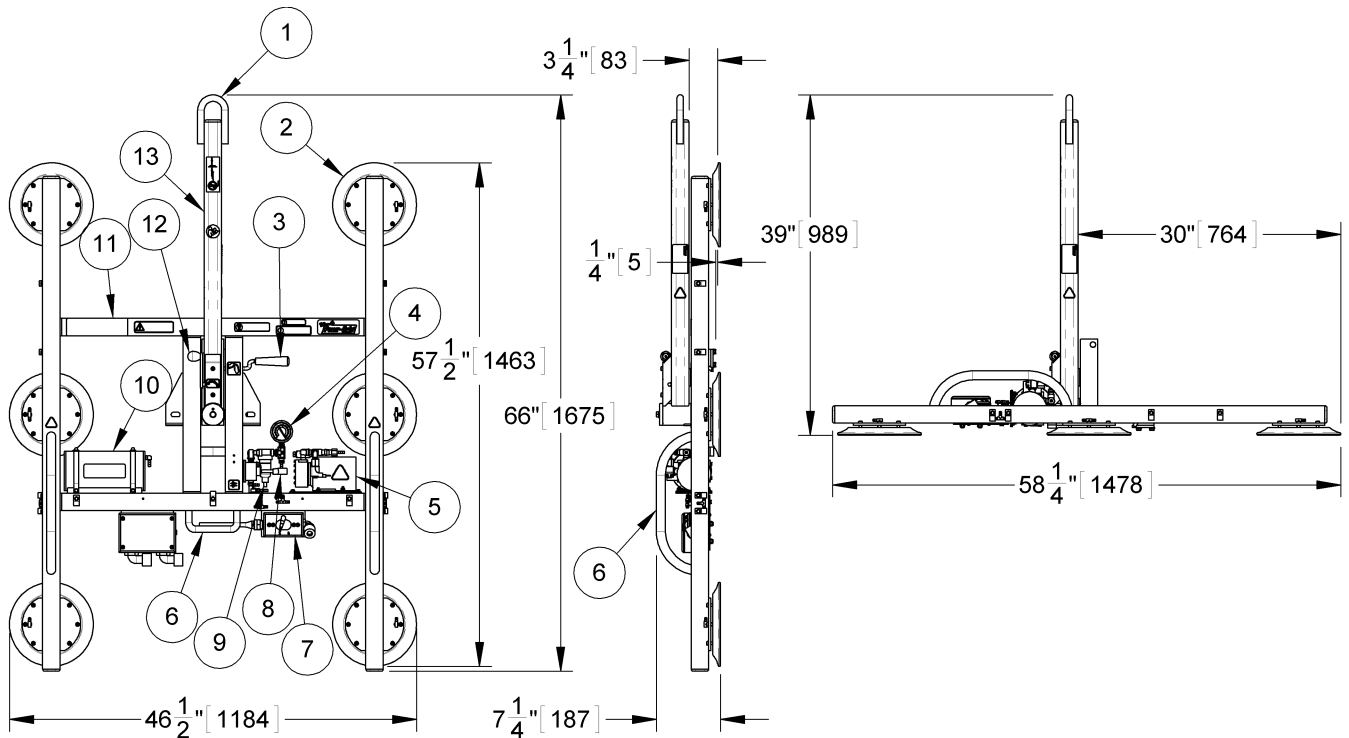

Standard PFV69AC shown.

- | | | |
|----------------------|------------------------|---------------------------|
| 1 LIFT BAIL | 5 VACUUM PUMP | 10 VACUUM RESERVE TANK |
| 2 VACUUM PAD | 6 CONTROL HANDLES | 11 PAD FRAME |
| 3 TILT RELEASE LEVER | 7 POWER SWITCH | 12 ROTATION RELEASE LEVER |
| 4 VACUUM GAUGE | 8 VACUUM CONTROL VALVE | 13 LIFT BAR |
| 9 AIR FILTER | | |

ASSEMBLY

- 1) Open the shipping container and remove all materials for restraining or protecting the vacuum lifter. Save the container for use whenever the lifter is transported.
- 2) Suspend the lifter from a crane as follows: Select hoisting equipment (crane and hoist, when applicable) rated to carry the maximum load weight plus the lifter weight (see SPECIFICATIONS: Maximum Load Capacity and Lifter Weight).

Note: Any application of the lifter must conform to all statutory or regulatory standards that relate to the hoisting equipment when used in its geographical location (eg, relevant OSHA standards in the USA).

Tilt the lifter upward on its parking feet (integrated in pad frame) high enough for the lift bar to move freely, without interference from the shipping container. Swing the lift bar to the center position of the 180° rotation range, where it latches in position automatically.

 **WARNING: Hoisting equipment hook must be fitted with restraining latch to prevent lift bail from slipping off under any circumstances.**

Disengage the tilt latch (see OPERATION: TO TILT THE LOAD) and raise the lift bar to a vertical orientation. Then attach the hoisting equipment hook to the lift bail.

Note: Some hoisting equipment hooks could interfere with an upright load that extends beyond the lifter's pad frame. If the load would contact the hook during lifter operation, the operator must prevent this by attaching a sling (or other rigging that does not interfere with the load) between the hook and the lift bail.

 **WARNING: Any sling used must be rated to carry maximum load weight plus lifter weight.**

Use the hoisting equipment to raise the lifter out of the shipping container. Be careful to avoid damaging any vacuum pads. Remove the pad covers and save them for use whenever the lifter is stored.

- 3) Connect the power cable from the lifter to the power source as follows: Wire the female connector provided to an appropriate current-protected power source (see serial number plate for power requirements).

 **WARNING: Wiring must be done by qualified personnel, taking all appropriate safety precautions.**

The power source must be equipped with a ground fault circuit interrupter, in order to reduce the risk of electrical shocks.

 **WARNING: Power source must be equipped with ground fault circuit interrupter.**

Make certain the power cable is routed so that it does not become tangled while operating the lifter or hoisting equipment. Then push the power cable's male connector into the female connector and twist to secure them together. Now the lifter is operational.

- 4) Perform Operational and Load Tests for the lifter as directed in MAINTENANCE: TESTING SCHEDULE.

INTENDED USE

LOAD CHARACTERISTICS

 **WARNING: This lifter is NOT intended for lifting hazardous materials, such as explosives or radioactive substances.**

The operator must verify that the lifter is intended to handle each load, in accordance with the following requirements:

- The load must not exceed the maximum allowable weight specified under Load Capacity (see SPECIFICATIONS).
- The load must be a single piece of nonporous or semiporous material with a flat and relatively smooth contact surface.² To determine whether the load is too porous or rough, perform the test under Vacuum Level on Other Surfaces (see OPERATION: TO ATTACH THE PADS TO A LOAD).
- The load's contact surface must be suitable for obtaining a friction coefficient of 1 with the lifter's vacuum pads (see MAINTENANCE: VACUUM PAD MAINTENANCE: Friction Coefficient), as verified by a friction test, or capacity should be derated appropriately. If necessary, contact Wood's Powr-Grip for help in conducting a friction test.
- In order to avoid damaging the vacuum pads, the load's surface temperature must not exceed the allowable Operating Temperatures (see SPECIFICATIONS). However, if such an application cannot be avoided, Wood's Powr-Grip does offer a heat-resistant rubber compound and other solutions that may enable you to lift loads with higher surface temperatures. Contact Wood's Powr-Grip or an authorized dealer for more information.
- While the *minimum* length and width of the load are determined by the Pad Spread (see SPECIFICATIONS), the *maximum* length and width are determined by the allowable overhang, or the amount of load material that can extend sideways beyond the vacuum pads without breaking or otherwise being damaged.

The allowable overhang depends on the kind of load material being lifted, the thickness of the material, and the angle at which it is handled (if any). Since materials such as glass, stone or sheet metal each have different physical properties, the allowable overhang must be evaluated separately for each type of load. If necessary, contact Wood's Powr-Grip or an authorized dealer for help in determining the recommended overhang in a specific situation.

- 1" [2.5 cm] is the maximum allowable thickness of loads at the maximum weight (see SPECIFICATIONS: Maximum Load Capacity). However, allowable thickness increases as load weight decreases. If necessary, contact Wood's Powr-Grip for help in determining the maximum thickness permitted when handling any specific load.

Note: Vacuum pads can stain or deform load surfaces with light colors or soft coatings. The operator should test such surfaces for detrimental effects before using the lifter on them.

² Lifters that feature concave vacuum pads can also attach to some kinds of curved loads. Since curvature affects the lifting capacity, contact WPG for help in determining the Maximum Load Capacity for a particular curved load.

OPERATING ENVIRONMENT

The operator must determine whether the lifter is intended to be used in each work environment, in accordance with the following restrictions:

 **WARNING: Never use lifter in dangerous environments.**

- This lifter is not intended for use in any environment that is inherently dangerous to the operator or likely to compromise the lifter's ability to function. Environments containing explosives, caustic chemicals and other dangerous substances must be avoided when using the lifter.
- The lifter's work environment is limited by the Operating Elevation and Operating Temperatures indicated in SPECIFICATIONS.
- The lifter's work environment must be free of metal particles or any other contaminants that could damage lifter components through airborne contact or any other means of transmission in the environment. If such contaminants cause a vacuum pump failure, they could result in a load release and injury to the operator or others nearby.

 **WARNING: Environmental contaminants could result in vacuum pump failure.**

- Using the lifter in wet environments may require the operator to take special precautions: Moisture on contact surfaces of the load or vacuum pads diminishes the lifter's slip resistance, thereby reducing the lifting capacity (see MAINTENANCE: VACUUM PAD MAINTENANCE: Friction Coefficient).

 **WARNING: Moisture reduces slip resistance of vacuum pads.**

Although the lifter's exterior surfaces can tolerate some exposure to water vapor, they are not designed to be watertight. Submerging the lifter or using it in rain may damage lifter components; these and similar conditions must be avoided.

-
- **!!-CE-!!** If the lifter is employed in a construction area, CE Standard EN 13155 requires the use of a secondary positive holding device, such as a sling system, designed to support the load in case of a vacuum system failure.

 **WARNING: Where CE Standards apply, secondary positive holding device is required for lifting loads in construction zones.**

DISPOSAL OF THE LIFTER

After the vacuum lifter has reached the end of its service life, you must dispose of the lifter in compliance with all local codes and regulatory standards that are relevant for the geographical region.

OPERATION

BEFORE USING THE LIFTER

The operator must determine whether the lifter is capable of performing each intended task, in accordance with the SPECIFICATIONS and INTENDED USE sections of this *INSTRUCTIONS* manual. In addition, all of the following preparations must be completed prior to lifting any load.

Taking Safety Precautions

The operator must be trained in all relevant industry and regulatory standards for the operation of the vacuum lifter in its geographical location (eg, ASME B30.20 in the USA).

The operator must read and understand this *INSTRUCTIONS* manual, including all **WARNINGS**, before using the lifter. If necessary, contact Wood's Powr-Grip or an authorized dealer for assistance.

 **WARNING: Always wear appropriate personal protective equipment.**

The operator must wear any personal protective equipment and take any other precautions required to handle the load safely. Consult appropriate trade association guidelines to determine what precautions are necessary for each type of load material.

Performing Inspections and Tests

Perform all inspections and tests required by the INSPECTION and TESTING SCHEDULES (see MAINTENANCE). In addition, if the lifter has been in storage, always conduct a VACUUM TEST before placing it in service (see MAINTENANCE).

CAUTION: Examine each air filter regularly, and empty when necessary.

The lifter is equipped with one or more air filters to help protect the vacuum system from contaminants.³ In order for a filter to function, the operator must empty the filter bowl before enough liquid accumulates to contact any portion of the filter element (see MAINTENANCE: AIR FILTER MAINTENANCE).

³ In order for the operator to use the lifter on wet load surfaces, it must be equipped with 2 or more filters that are connected *in series*. However, see MAINTENANCE: VACUUM PAD MAINTENANCE: Friction Coefficient before using the lifter on wet load surfaces.

TO APPLY THE PADS TO A LOAD

Powering up the Lifter

Make sure the lever on the vacuum control valve is in the "release" (⇈) position: Pull outward on the lever's knob, move the lever to the downward position and release it.

Place the power switch in the "on" position (⏻), to engage the vacuum pump. The lifter is designed for the vacuum pump to run continuously.

⚠ WARNING: Never turn power off while operating lifter; keep pump running throughout lift.

The power switch must remain in the "on" position while operating the lifter. Placing the power switch in the "off" position (⏻) during lifter operation could result in the release of the load and possible injury to the operator (see TO LIFT AND MOVE THE LOAD: In Case of Power Failure to follow).

Positioning the Lifter on the Load

Make certain that the contact surfaces of the load and all vacuum pads are free of any contaminants that could prevent the pads from sealing against the load (see MAINTENANCE: VACUUM PAD MAINTENANCE).

Center the lifter's pad frame to within 2" [5 cm] of the load center, since off-center loading can cause the load to tilt unexpectedly (see TO TILT THE LOAD to follow), and it may also damage the lifter.⁴ Make sure that all vacuum pads will fit entirely on the load's contact surface (see SPECIFICATIONS: Maximum Pad Spread) and that they will be loaded evenly while lifting (see SPECIFICATIONS: Per-Pad Load Capacity). Then position the lifter on the load so that all pads are touching the contact surface.

Sealing the Pads against the Load

Move the lever on the vacuum control valve to the "apply" (⇈) position: Pull outward on the lever's knob, move the lever to the upward position and release it. This position opens the lifter's vacuum lines to the airflow created by the vacuum pump, causing air to be drawn immediately at the vacuum pads.⁵ Apply the lifter to the load until all pads seal against it.

⚠ WARNING: Keep valve lever in "APPLY" position throughout lift.

The valve lever must remain in the "apply" (⇈) position throughout the entire lift. Any interruption of the vacuum flow during lifter operation could result in the release of the load and possible injury to the operator.

Note: If a vacuum pad has been lying against a hard object (as during shipping), it may be slightly distorted. Although initially it may be difficult to apply the pad to a load, this condition should correct itself with continued use.

⁴ The lifter is designed to handle the maximum load weight (see SPECIFICATIONS: Maximum Load Capacity) when the load's center of gravity is positioned within 2" [5 cm] of the pad frame's center point. Occasional loading deviations are permissible, provided that the operator can maintain control of the load at all times and that the load weight is low enough to avoid damaging the lifter.

⁵ To minimize the time it takes for the lifter to attach and obtain full vacuum, do not place the valve lever in the "apply" position until the vacuum pads are contacting the load.

Reading the Vacuum Gauge

The vacuum gauge indicates the current vacuum level in the lifter's vacuum system. The *green* range indicates vacuum levels sufficient for lifting the maximum load weight, whereas the *red* range indicates vacuum levels that are **not** sufficient for lifting the maximum load weight. The gauge needle should show a sudden surge in vacuum as the vacuum pads seal against the load. If it takes more than 5 seconds for the vacuum level to reach 5" Hg [-17 kPa], press on any pad that has not yet sealed.

Vacuum Level on Optimal Surfaces

When the lifter is attached to clean, smooth, nonporous load surfaces, it should be able to maintain a vacuum level in the green range on the vacuum gauge, except when used at high elevations (see SPECIFICATIONS: Operating Elevation). If not, perform the VACUUM TEST (see MAINTENANCE) to determine whether there is a deficiency in the vacuum generating system.

Vacuum Level on Other Surfaces

When the lifter is attached to contaminated, rough or porous load surfaces, it may not be able to maintain a vacuum level in the green range on the vacuum gauge, due to leakage in the seal between the vacuum pads and the load surface. In the case of contamination, thoroughly clean the contact surfaces of the load and the vacuum pads (see MAINTENANCE: VACUUM PAD MAINTENANCE: Cleaning), and reapply the lifter to the load. If the load has rough or porous surfaces, ***the operator must conduct a test to determine whether the lifter is designed to lift the load***, as follows:

- 1) Make sure the lifter's vacuum generating system is functioning correctly (see MAINTENANCE: VACUUM TEST).
- 2) Apply the vacuum pads to the load as previously directed.
- 3) When the vacuum level registers above 16" Hg [-54 kPa] on the vacuum gauge (see TO LIFT AND MOVE THE LOAD: Load Capacity and the Vacuum Gauge to follow), place the power switch in the "off" () position.
- 4) Raise the load a minimal distance, to assure that it is supported by the lifter.
- 5) Monitor the vacuum gauge while the load is suspended for 5 minutes: ***The lifter must maintain a minimum vacuum level of 10" Hg [-34 kPa] during this time.*** If not, the load does not possess the characteristics required for using this lifter.⁶

⁶ Certain load materials are too rough or porous to allow the lifter to form a seal which can be maintained for 5 minutes without power. However, in geographical locations where CE Standards do not apply, it may be possible to use the lifter to lift such loads. Contact Wood's Powr-Grip for more information.

TO LIFT AND MOVE THE LOAD

Positioning the Lift Bar

⚠ WARNING: Lift bar must be oriented vertically to lift load.

Never lift the load from a flat position with the lift bar latched parallel to the load. Always disengage the tilt latch (see TO TILT THE LOAD to follow) and raise the lift bar to a vertical orientation before attempting to lift.

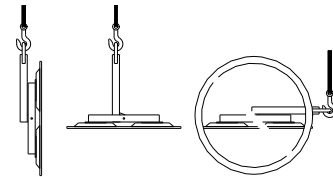

Load Capacity and the Vacuum Gauge

A lifter's Load Capacity is rated at a vacuum level of 16" Hg [-54 kPa] (see SPECIFICATIONS). Vacuum higher than this level registers in the green range on the vacuum gauge, to indicate that the lifter is ready to lift the maximum load weight.

⚠ WARNING: Never attempt to lift load unless vacuum level registers higher than 16" Hg [-54 kPa].

Do not attempt to lift the load while vacuum registers lower than 16" Hg [-54 kPa]; such an attempt could result in a load release and possible injury to the operator.

Monitoring the Vacuum Gauge

The vacuum gauge must remain completely visible to the operator, so that it can be monitored throughout the entire lift.

⚠ WARNING: Vacuum gauge must be visible to operator throughout entire lift.

The lifter's vacuum pump runs continuously to maintain sufficient vacuum for lifting the maximum load weight. If the vacuum system experiences leakage while the lifter is attached to the load, the vacuum gauge signals the reduction in vacuum to the operator. Make sure the vacuum gauge shows a vacuum level of 16" Hg [-54 kPa] or higher while you are lifting a load. If not, move away and stay clear of the load until it can be lowered to the ground or a stable support.

⚠ WARNING: Stay clear of any suspended load while vacuum level is lower than 16" Hg [-54 kPa].

Discontinue lifter use until the cause of the vacuum loss can be determined. If the vacuum level remains lower than 16" Hg [-54 kPa] when the lifter is attached to clean, smooth, nonporous materials, the leakage is likely to be in the vacuum system. In this event, perform the VACUUM TEST (see MAINTENANCE) and inspect the vacuum pads for damage (see MAINTENANCE: VACUUM PAD MAINTENANCE: Inspection). If the vacuum loss cannot be remedied immediately, perform inspection and maintenance as needed to identify and correct any deficiency before resuming normal operation of the lifter.

Controlling the Lifter and Load

When the vacuum gauge indicates that the lifter is ready, use the hoisting equipment to raise the lifter and load as needed to clear any obstacles in their path. Use the control handles to keep the lifter and load in the desired orientation while they are suspended from the crane. Once sufficient clearance is established, the load can be rotated or tilted as desired (see TO ROTATE THE LOAD EDGEWISE or TO TILT THE LOAD to follow).

In Case of Power Failure

The lifter is equipped with a vacuum reserve tank, designed to maintain vacuum temporarily in case of a power failure.



WARNING: Stay clear of any suspended load in the event of a power failure.

Although the lifter is designed to support the load for at least 5 minutes without power, this depends on many factors, including the condition of the load and the lifter's vacuum system (see INTENDED USE: LOAD CHARACTERISTICS and MAINTENANCE: VACUUM PAD MAINTENANCE, VACUUM TEST). If a power failure occurs, keep all personnel clear of the suspended load until it can safely be placed on the ground or a stable support. Correct any deficiency before resuming normal operation of the lifter.

TO ROTATE THE LOAD EDGEWISE

⚠ WARNING: Never disengage both the rotation latch and the tilt latch at the same time.

This lifter is not designed for rotation and tilt functions to be used at the same time. Disengaging the rotation and tilt latches simultaneously could cause uncontrolled and unpredictable load movement, potentially resulting in load damage or injury to the operator.

CAUTION: Rotation function only works when pad frame is latched in vertical orientation.

Make sure the pad frame is latched in the vertical position of the tilt range (see To TILT THE LOAD to follow), as shown in the OPERATING FEATURES illustration, because the rotation function is not designed to work in any other position.

⚠ WARNING: Make sure load is positioned correctly on lifter (see To APPLY); unbalanced loads may rotate unexpectedly when latch is disengaged.

Remember that the load is longer in its diagonal dimensions than in its side dimensions. Make sure there is sufficient clearance for the load to rotate without contacting the operator or any nearby objects. Maintain a firm grip on one control handle to keep the load under control at all times. Pull the rotation release lever to disengage the rotation latch, and rotate the load to the desired position. To stop the load's motion automatically at each quarter turn, simply let go of the rotation release lever immediately after initiating the rotation, so that the rotation latch engages at the next stop. Whenever rotation is not required, keep the rotation latch engaged, to prevent accidental damage to the load and possible injury to the operator.

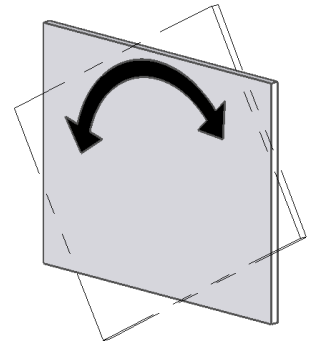

TO TILT THE LOAD

⚠ WARNING: Never disengage both the rotation latch and the tilt latch at the same time.

This lifter is not designed for rotation and tilt functions to be used at the same time. Disengaging the rotation and tilt latches simultaneously could cause uncontrolled and unpredictable load movement, potentially resulting in load damage or injury to the operator.

CAUTION: Tilt function only works when pad frame is latched in center position of rotation range.

Make sure the pad frame is latched in the center position of the rotation range (see TO ROTATE THE LOAD EDGEWISE preceding), as shown in the OPERATING FEATURES illustration, because the tilt function is not designed to work in any other position.

⚠ WARNING: Make sure load is positioned correctly on lifter (see To APPLY); unbalanced loads may tilt unexpectedly when latch is disengaged.

Remember that the load requires more vertical space when tilted to the upright position, as well as more horizontal space when tilted to the flat position. Make sure there is sufficient clearance for the load to tilt without contacting the operator or any nearby objects. Maintain a firm grip on one control handle to keep the load under control at all times. If the pad frame is latched in the vertical position, pull the tilt release lever to disengage the tilt latch, and prepare for a slight surge of motion as the load begins to tilt. If load size permits, maintain control with the handle throughout the tilt. For loads with overhang, it may be necessary to release the control handle as the load approaches the flat position. If so, keep the load under control using hand cups or other appropriate means. The pad frame automatically latches in place when it returns to the vertical position.

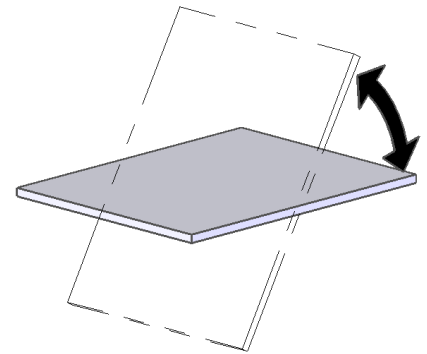

TO RELEASE THE PADS FROM THE LOAD

 **WARNING:** *Load must be fully supported before releasing vacuum pads.*

When the load is at rest and fully supported, move the lever on the vacuum control valve to the "release" (☞) position: Pull outward on the lever's knob, move the lever to the downward position and then release it. This forces air into the vacuum pads, quickly breaking the vacuum seal. After the pads have disengaged completely from the load, move the lifter away. Leave the valve lever in the release position until ready to attach to the next load.

AFTER USING THE LIFTER

Leave the lever on the vacuum control valve in the "release" (☞) position and place the power switch in the "off" (⊖) position.

CAUTION: *Do not set the lifter against any surfaces which could soil or damage the vacuum pads.*

Built-in parking feet can be used to support an unloaded lifter when not suspended from a crane: Make sure the pad frame is oriented vertically with the parking feet at the bottom. Use the hoisting equipment to gently lower the lifter until the parking feet support its entire weight. Make sure the lifter leans securely against an appropriate support; then detach the hoisting equipment hook from the lift bail.

If the lifter is transported to another location, use the original shipping container and secure the lifter so as to protect the vacuum pads and all other components from damage while in transit.

Storing the Lifter

Use the covers supplied to keep the vacuum pads clean.

~~~~~  
**!!-CE-!!** In accordance with CE Standard EN 13155, the lifter is designed to rest on relatively horizontal surfaces without tipping over. To store the lifter in this way, set the lifter with the pads facing downward on a clean, smooth, flat surface. Then lower the lift bar to a horizontal orientation and place a support under the lift bail.  
~~~~~

MAINTENANCE



WARNING: Make sure power cable is disconnected from power source before servicing lifter.

Note: One or more wiring diagrams may be provided in the final section of this *INSTRUCTIONS* manual for reference when servicing the lifter or trouble-shooting a deficiency.

INSPECTION SCHEDULE

Perform inspections routinely, according to the following frequency schedule:

Every-Lift Inspection

- Examine the vacuum pads and load surface for contamination or debris (see VACUUM PAD MAINTENANCE to follow).
- Examine the vacuum pads, controls and indicators for visual damage (see VACUUM PAD MAINTENANCE to follow).

If any deficiency is detected during the inspection, correct it before using the lifter and perform the Frequent Inspection to follow.

Frequent Inspection

(following every 20-40 hours' use; or whenever lifter is out of service for 1 month or more)

- Examine the lifter's structure for visual damage.
- Examine the vacuum system (including vacuum pads, fittings and hoses) for visual damage.
- Examine the air filter for conditions requiring service (see AIR FILTER MAINTENANCE to follow).
- Perform the VACUUM TEST to follow.
- Check for unusual vibrations or noises while operating the lifter.

If any deficiency is detected during the inspection, correct it before using the lifter and perform the Periodic Inspection to follow.

Periodic Inspection

(following every 250-500 hours' use; or whenever lifter is out of service for 1 year or more)

- Examine the entire lifter for external evidence of looseness, excessive wear, deformation, cracks, excessive corrosion, dents to structural or functional components, cuts, or any deficiency that might constitute a hazard.
- Inspect all parts of the electrical system for damage, wear or contamination that could constitute a hazard, in compliance with all local codes and regulatory standards that are relevant for the geographical region.

CAUTION: Be sure to use appropriate cleaning methods for each type of electrical component, as specified by codes and standards. Improper cleaning can damage components.

- Keep a written record of all Periodic Inspections.

If any deficiency is detected during the inspection, correct it before using the lifter. If necessary, return the lifter to Wood's Powr-Grip or an authorized dealer for repair (see LIMITED WARRANTY).

Infrequent Use

If a lifter is used less than 1 day in a 2-week period, perform the Periodic Inspection *each time before using the lifter*.

TESTING SCHEDULE

Perform these tests when placing the lifter in service *initially* and *each time following a repair or modification*. Correct any deficiency and retest before using the lifter.

Operational Tests

- Perform the VACUUM TEST to follow.
- Test all features and functions of the lifter (see OPERATING FEATURES, OPERATION and MAINTENANCE).

Load Test

Confirm that the lifter can lift 100% of its Maximum Load Capacity (see SPECIFICATIONS), using an actual load or an equivalent simulation.⁷ Employ the following method to test with an actual load:

- 1) Place a test load with appropriate LOAD CHARACTERISTICS (see INTENDED USE) on a stable support. Make sure the load is oriented in the upright position.⁸
- 2) Attach the vacuum pads to the load as previously directed.
- 3) When the vacuum level registers above 16" Hg [-54 kPa] on the vacuum gauge, place the power switch in the "off" position (⊖).
- 4) Raise the load a minimal distance, to make sure it is supported by the lifter.
- 5) Hold the load for 5 minutes. The load must not slip or fall during this time period. If it does, conduct a VACUUM TEST and inspect each vacuum pad as indicated under VACUUM PAD MAINTENANCE: Inspection (see sections to follow). Correct any deficiency that is found and retest the lifter.

Note: See MAINTENANCE topics to follow for additional directions about inspecting and testing specific lifter components.

⁷ ASME Standard B30.20 requires the lifter to be tested to 125% of its Load Capacity.

⁸ Flat Lifters are exempt from this requirement.

MAINTENANCE SCHEDULE

Unless specified elsewhere in this *INSTRUCTIONS* manual, the lifter does not require maintenance on a routine basis. Instead, maintenance must be performed whenever a deficiency is indicated by routine inspections or tests. Any maintenance warranted must be performed before resuming normal operation of the lifter.

VACUUM PAD MAINTENANCE

Friction Coefficient

The friction coefficient represents the lifter's ability to resist load slippage when the load is oriented in any position except horizontal. If the contact surfaces of either the load or the vacuum pads are not clean, dry and in good condition, slippage is more likely to occur.

The Load Capacity of most Powr-Grip lifters is based on a friction coefficient of 1 (only Flat Lifters are exempt from this requirement). However, a vacuum pad's ability to maintain this friction coefficient is reduced by factors such as contamination, wear, age and exposure to sunlight, as well as the condition of the load's contact surface (see INTENDED USE: LOAD CHARACTERISTICS). Pads that have surface contamination must be thoroughly cleaned (see Cleaning discussion to follow). Over time, the rubber in a pad may experience hardening or leaching of chemicals, resulting in stiffness or surface glaze. Pads that exhibit wear, stiffness or glaze must be replaced. In addition, all pads should be replaced every 2 years, to make sure that the friction coefficient is not compromised. If necessary, contact your dealer or Wood's Powr-Grip for more information.

Inspection

Inspect each vacuum pad for the following deficiencies routinely, as directed in the preceding INSPECTION and TESTING SCHEDULES. Correct any deficiency before using the lifter.

- Contaminates on the pad face or sealing edges: Soil build-up can prevent pads from sealing adequately or reduce the friction coefficient (see discussion preceding). Follow the directions to clean pads as necessary (see discussion to follow).
- Filter screen missing from pad face: This screen helps prevent debris from plugging the vacuum hose and the air filter. Replace any missing screen immediately (see REPLACEMENT PARTS LIST).
- Nicks, cuts or abrasions in sealing edges: Pad damage can reduce the lifting capacity of the lifter. Replace any damaged pad immediately (see REPLACEMENT PARTS LIST).⁹

 **WARNING: Replace vacuum pad if sealing edge has any nicks, cuts or abrasions.**

- Wear, stiffness or glaze: See Friction Coefficient preceding. Replace any pad that exhibits wear, stiffness or glaze (see REPLACEMENT PARTS LIST).

⁹ If the lifter is equipped with VPFS10T or VPFS625 pads, the sealing edge is the replaceable sealing ring/insert. When it is damaged, install a new one. In such cases, see TO REPLACE SEALING RING/INSERT IN VACUUM PAD to follow.

Cleaning

Regularly clean the face of each vacuum pad to remove oil, dust and any other contaminants. Acceptable cleaning agents include soapy water and other mild cleansers. Do *not* use solvents, petroleum-based products (including kerosene, gasoline and diesel fuel) or any harsh chemicals for cleaning. Do *not* use unauthorized rubber cleaners or conditioners, such as those intended for cleaning tires or vinyl surfaces, because those products can leave a hazardous film on vacuum pads that significantly reduces lifting capacity (see Friction Coefficient preceding). The use of any unauthorized cleaning agent is prohibited, because it could damage the pad and/or create a hazard to the operator or others.

 **WARNING: Never use solvents, gasoline or other harsh chemicals to clean vacuum pad.**

 **WARNING: Never use unauthorized rubber cleaners or conditioners to clean vacuum pad.**

To prevent liquid from contaminating the vacuum system during cleaning, cover the suction hole in the recess for the filter screen or make sure the pad faces downward. Use a clean sponge or lint-free cloth to apply an authorized cleanser and wipe the pad face clean. A toothbrush (or similar brush with bristles *that do not harm rubber*) may be used to remove contaminants clinging to sealing edges.¹⁰ Wipe all residue from the pad face, and allow the pad to dry completely before using the lifter.

VACUUM TEST

Test the vacuum system for leakage routinely, as directed in the preceding INSPECTION and TESTING SCHEDULES.

- 1) Clean the face of each vacuum pad as previously directed (see VACUUM PAD MAINTENANCE: Cleaning).
- 2) Attach the lifter to a clean, smooth, nonporous surface. The surface should be flat or possess no more curvature than the lifter is designed for (if any).¹¹
- 3) When the vacuum level registers above 16" Hg [-54 kPa] on the vacuum gauge, place the power switch in the "off" position (⊖) and leave the pads attached to the surface.
- 4) Monitor the vacuum gauge: *The vacuum level should not decrease by more than 4" Hg [-14 kPa] in 10 minutes.*

 **WARNING: If lifter fails vacuum test, discontinue use immediately.**

Correct any deficiency in the vacuum system before using the lifter. Contact Wood's Powr-Grip or an authorized dealer for assistance.

¹⁰ If these cleaning methods are not successful, contact Wood's Powr-Grip or an authorized dealer for assistance.

¹¹ Any test material used must be fully and independently supported, and capable of bearing the lifter's weight. Do not use the lifter to lift the test material during the vacuum test.

AIR FILTER MAINTENANCE – SMALL

(For 1 oz [30 ml] bowl size filters)

Filter Function and Conditions Requiring Service

An air filter prevents solid particles and liquid from contaminating components in the vacuum system.

CAUTION: Examine air filter regularly and empty when necessary.

Liquid must not contact any portion of the filter element; remove trapped liquid regularly. Replace the element if it has an overall dirty appearance, or if there is a noticeable increase in the time required to attain full vacuum. (Refer to REPLACEMENT PARTS LIST for filter element kit.)

Filter Service Procedures

- 1) Unscrew the bowl (6) from the body (1). Support the body while twisting the bowl, to protect the vacuum line fittings from being damaged.
- 2) Determine whether the filter element (4) needs to be replaced (see Conditions Requiring Service preceding). *If so*, proceed to step 3.
If not, remove any liquid or contaminants from the bowl; clean the old bowl seal (2) with mild soap and water; and skip to step 7.
- 3) Unscrew the element holder (5) and remove all internal parts.
- 4) Set aside the element, element gaskets (7) and bowl seal for disposal later.
- 5) Clean all other internal parts and the bowl, using mild soap and water only. *Do not* use any other cleansing agents.
- 6) Place the new element gaskets and element, along with the old deflector (3), on the element holder, and screw the assembly back into the filter body (tighten gently, finger-tight).
- 7) Lubricate the new or cleaned bowl seal (2)¹², using a mineral base oil or grease (such as the lubricant furnished in the filter element kit). *Do not* use synthetic oils, such as esters, and *do not* use silicones.
- 8) Place the bowl seal around the rim of the bowl. Then screw the bowl back into the body, taking care to avoid contaminating the filter element with lubricant. Hand-tighten only.
- 9) Test the vacuum system to be certain the air filter does not leak (see VACUUM TEST preceding, if applicable).

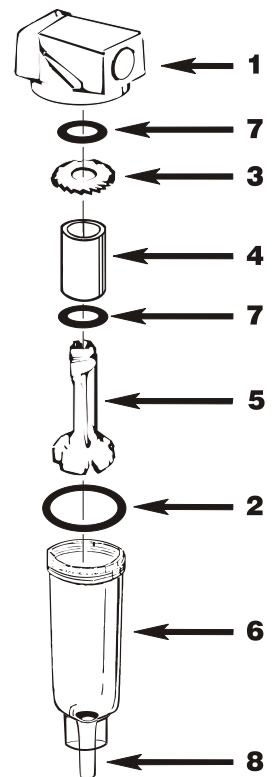

⚠ WARNING: When the air filter is being used on a *vacuum* system, rather than with pressure, using the twist drain (8) to remove liquid from the bowl is **not** recommended. **Never** disturb the twist drain, as contaminants could lodge in the drain seal and cause a vacuum leak.

¹² The filter element kit may contain two sizes of bowl seals (O-ring type gaskets). If so, use the smaller bowl seal; or if in doubt, compare the old bowl seal to determine the appropriate size.

VACUUM PUMP MAINTENANCE – GAST 3032 & 2032

(for Gast pump nos. 3032-101A-G609X and 2032-101-G616X)

⚠ WARNING: Before proceeding with any maintenance, disconnect power source; allow pump to cool; and vent any vacuum or pressure remaining in vacuum system.

If the vacuum pump takes too long to attain full vacuum, it may require maintenance, as directed in the following disassembly/reassembly procedure. Service or replace air filters and vanes as necessary to obtain acceptable pump performance (see service kit in REPLACEMENT PARTS LIST). Note: Inspect air filters after no more than 500 hours of operation; dirty filters must be cleaned or replaced.

1) Remove the retainer bolts (7 & 8) from the vacuum pump.

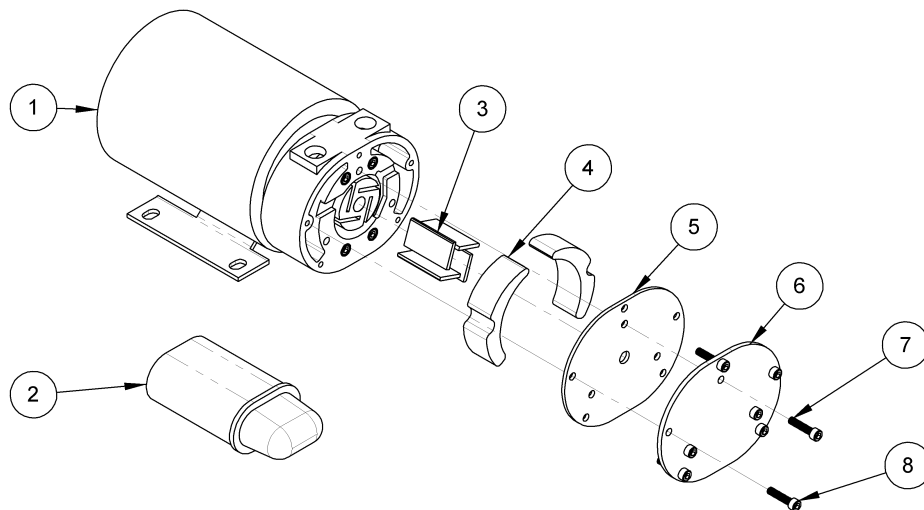

- 1 MOTOR W/ROTOR HOUSING
- 2 CAPACITOR
- 3 VANES (4x)
- 4 AIR FILTERS (2x)
- 5 INSERT PLATE
- 6 RETAINER PLATE
- 7 LONG RETAINER BOLT (3x)
- 8 SHORT RETAINER BOLT (5x)

- 2) Remove the retainer plate (6) and insert plate (5) by lightly tapping on them with a small hammer. Note: Do not use a screwdriver to remove these plates, because it could damage them.
- 3) Before removing the existing vanes (3), note the direction of the beveled edge, in order to install the new vanes in the same orientation. Do not try to remove the rotor, because it can only be serviced by the manufacturer.
- 4) Spray the bore and rotor with a suitable, nonpetroleum-based flushing solvent. Use a clean, dry cloth to remove flushing solvent from these parts.
- 5) Place the new vanes (3) in the rotor slots with the beveled edge in the correct orientation (see step 3). Note: Vanes may become damaged or broken if installed incorrectly.
- 6) If the air filters (4) appear dirty, clean them with soapy water or replace them all together, depending on their condition. After cleaning the filters, dry them with compressed air. Since moisture can damage the pump, be sure to avoid introducing any moisture into the pump. When the filters are completely dry, reinstall them in the rotor housing. Otherwise, install new filters.
- 7) Place a sheet of fine emery cloth on a smooth, flat surface and rub both sides of the insert plate (5) on the emery cloth to remove any burrs. Use a clean, dry cloth to remove any dust from the insert plate. Reinstall the insert plate, placing the unused side facing the pump vanes.
- 8) Repeat step 7 with the face of the retainer plate (6). Use a clean, dry cloth to remove any dust from the retainer plate and reinstall it.
- 9) Reinstall the retainer bolts (7 & 8) and tighten them to 28-36 in-lbs [3.1-4.1 N-m] of torque.

REPLACEMENT PARTS LIST

Stock No.	Description	Qty.
66207	Pump Service Kit – 240 V AC (including vanes and filters)	1
66205	Pump Service Kit – 120 V AC (including vanes and filters)	1
66142AM	Vacuum Pump – Rotary Vane Type – 2.5 SCFM – 240 V AC	1
66142	Vacuum Pump – Rotary Vane Type – 2.5 SCFM – 120 V AC	1
65440	Vacuum Hose – 1/4" ID	*
65275	Vacuum Control Valve w/Lever	1
65234	Solenoid Valve – 240 V AC – 6 W	1
65226	Solenoid Valve – 120 V AC – 6 W	1
65212AM	Check Valve – 1/4 NPT – 0.15 PSI Cracking Pressure	1
65010	Pad Spring – Coil Type	**
64355	Adjustable Time Delay Relay – 18-240 V AC – 1.5 A	1
64176	Power Switch	1
53132	Hose Fitting – Tee – 5/32" ID	**
53128	Pad Fitting – Tee – 5/32" ID	**
53122	Pad Fitting – Elbow – 5/32" ID	**
49605T	Vacuum Pad – Model HV11 / 10" [25 cm] Diameter – Lipped (optional)	**
49506TA	Vacuum Pad – Model VPFS9 / 9" [23 cm] Diameter	**
49122	End Plug – 2" x 2" x 1/4" Tubing Size	**
49110	End Plug – 2" x 2" x 3/16" Tubing Size	**
29353	Pad Cover	**
16134	Filter Element Kit (for 1 oz bowl size air filter)	1
15930	Vacuum Gauge – 1/4 NPT – LM Type	1
15794	Tilt Release Lever Handle	1
15792	Rotation Release Lever Knob	1
15632	Pad Filter Screen – Small (for VPFS9 pad)	**
15630	Pad Filter Screen – Large (for HV11 pads)	**
10900	Shoulder Bolt – Socket Head – 5/16" x 1/2" x 1/4-20 Thread (for mounting pads)	**

* Length as required; replacement vacuum hose sold by the foot (approx. 30.5 cm).

** Quantity varies, depending on lifter model or options selected.

***SERVICE ONLY WITH IDENTICAL REPLACEMENT PARTS,
AVAILABLE AT WPG.COM OR THROUGH AN AUTHORIZED WPG DEALER***

LIMITED WARRANTY

Powr-Grip products are carefully constructed, thoroughly inspected at various stages of production, and individually tested. They are warranted to be free from defects in workmanship and materials for a period of one year from the date of purchase.

If a problem develops during the warranty period, follow the instructions hereafter to obtain warranty service. If inspection shows that the problem is due to defective workmanship or materials, Powr-Grip will repair the product without charge.

WARRANTY DOES NOT APPLY WHEN:

Modifications have been made to the product after leaving the factory.

Rubber portions have been cut or scratched during use.

Repairs are required due to abnormal wear and tear.

The product has been damaged, misused or neglected.

If a problem is not covered under warranty, Powr-Grip will notify the customer of costs prior to repair. If the customer agrees to pay all repair costs and to receive the repaired product on a C.O.D. basis, Powr-Grip then will proceed with repairs.

TO OBTAIN REPAIRS OR WARRANTY SERVICE

For purchases in *North America*:

Contact the Technical Service Department at Wood's Powr-Grip Co. When factory service is required, ship the complete product—prepaid—along with your name, address and phone number to the street address hereafter.

For purchases in *all other localities*:

Contact your dealer or the Technical Service Department at Wood's Powr-Grip Co. for assistance.

Wood's Powr-Grip Co., Inc.
908 West Main St. / P.O. Box 368
Laurel, MT USA 59044

phone 800-548-7341

phone 406-628-8231

fax 406-628-8354

WIRE LEGEND: CONTROLLED BY WIRING SYMBOLS DRAWING EXCEPT AS NOTED AND BELOW. LINE STYLES AND WIDTHS FOR WIRE UNLESS NOTED OTHERWISE: --- 20AWG --- 18AWG --- 16AWG --- N/A		TYPE: STANDARD DIRECTORY: H:\Working\STD\708-ACPP\ECN 3598\708B-W01 [B-W02] THIS DRAWING IS THE PROPERTY OF WOOD'S POWR-GRIP CO., INC. IT IS LOANED WITH THE UNDERSTANDING THAT NEITHER IT NOR ANY INFORMATION CONTAINED THEREIN WILL BE COPIED, PUBLISHED OR TRANSMITTED TO OTHERS WITHOUT EXPRESS WRITTEN PERMISSION. 1 LAUREL MONTANA U.S.A.	
PRODUCT MANAGER: ADRIEN L.	DATE: 01/07/2011	3 SCFM AC VACUUM PACKAGE COMPACT ROTARY VANE 120VAC GAST 3032 VAC PUMP WIRING DIAGRAM, NEAR CAPACITOR D708B-W01 [B-W02]	
CHECKED: <i>AR</i>	DATE: 12-15-14	SCALE: A NONE	REV.: 2
APPROVED: <i>AMM</i>	DATE: 11/07/2014	ECN NUMBER: 3598	BY: DTM
			EST. WEIGHT: N/A

NOTES:
 1) USE THIS DRAWING WHEN THE PUMP AND CAPACITOR ENCLOSURE ARE LESS THAN 10" APART.

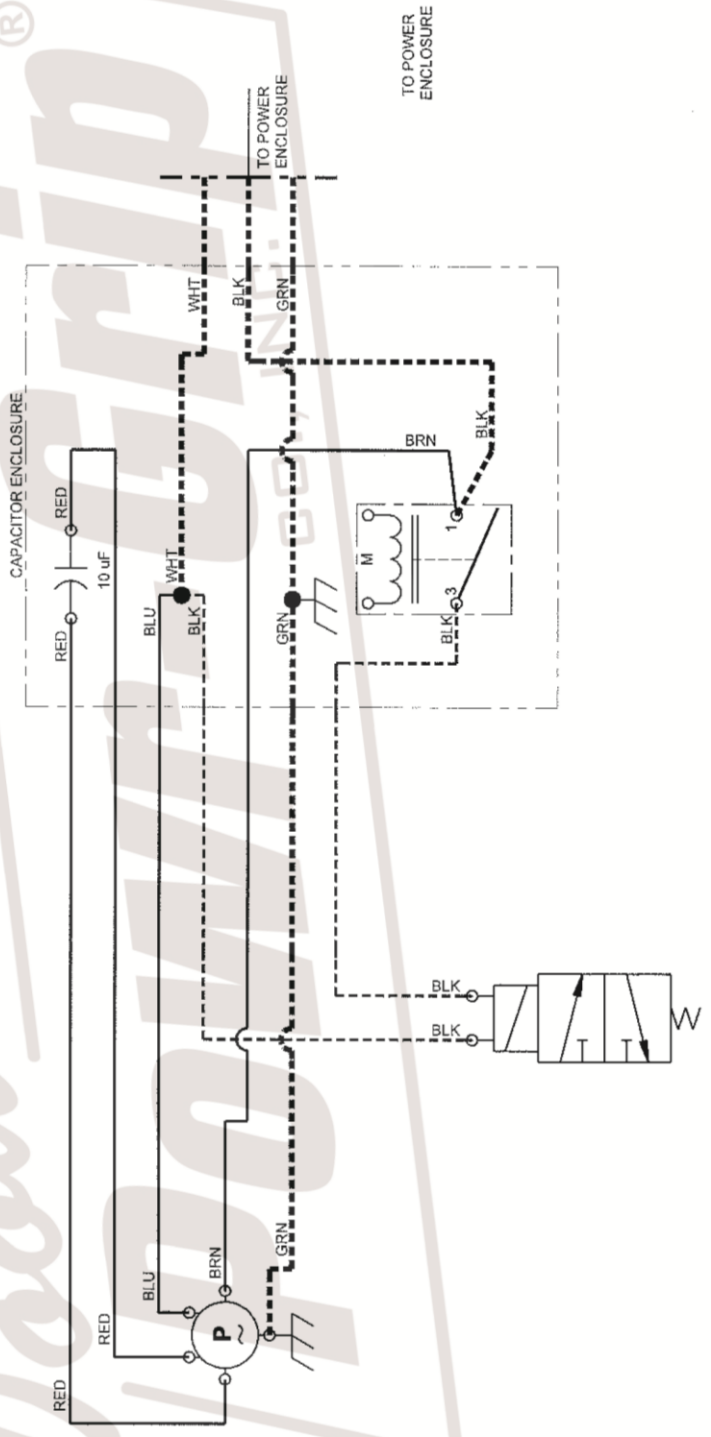

WIRE LEGEND: CONTROLLED BY WIRING SYMBOLS DRAWING EXCEPT AS NOTED AND BELOW. LINE STYLES AND WIDTHS FOR WIRE UNLESS NOTED OTHERWISE. --- 20AWG --- 18AWG --- 16AWG --- 14AWG --- 12AWG --- 10AWG --- 8AWG --- 6AWG --- 4AWG --- 2AWG --- 1AWG --- N/A		TYPE: STANDARD DIRECTORY: 708B-W01 [B-W03] FILE (SHEET):
DRAWN: L. RENNER CHECKED: <i>CR</i> APPROVED: <i>Chm</i>	DATE: 12/08/2011 01-11-12 1-11-12	THIS DRAWING IS THE PROPERTY OF WOOD'S POWR-GRIP CO., INC. IT IS LOANED WITH THE UNDERSTANDING THAT NEITHER IT NOR ANY INFORMATION CONTAINED THEREIN WILL BE COPIED, PUBLISHED OR TRANSMITTED TO OTHERS WITHOUT EXPRESS WRITTEN PERMISSION. 3 SCFM AC VACUUM PACKAGE COMPACT ROTARY VANE 240VAC GAST 2032 VAC PUMP WIRING DIAGRAM D708B-W01 [B-W03]
SIZE: A SCALE: NONE REV: 0 ECN NUMBER: 2761, REL. FOR PROD. DATE: 12/08/2011 BY: LER		H:\Working\STD\708-AC\PIECN 2761

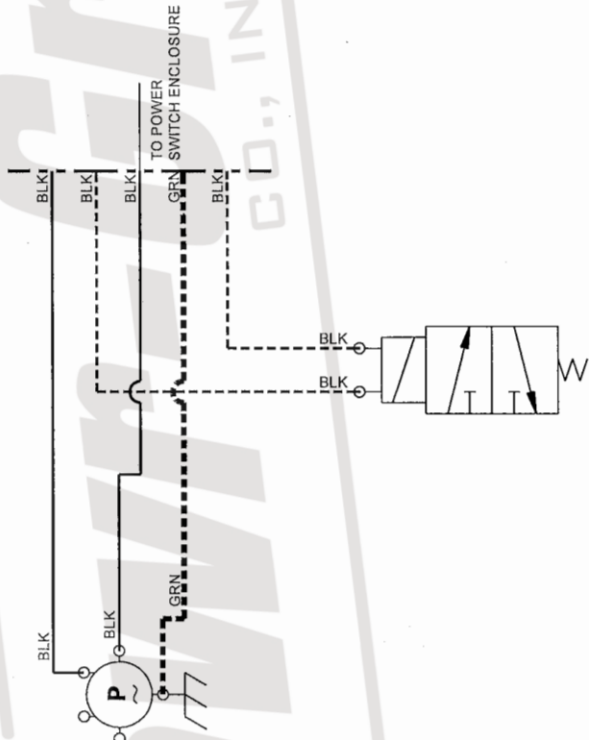
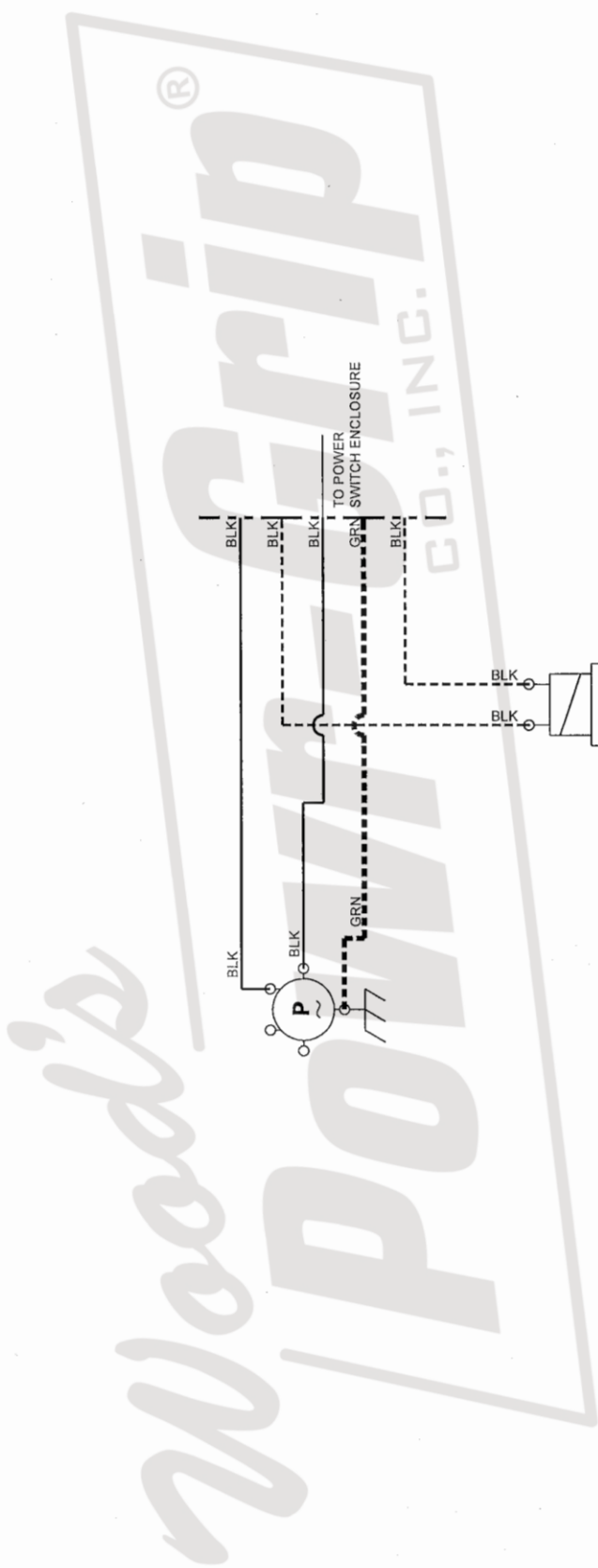

DIRECTORY:
FILE (SHEET):

STANDARD

WIRE LEGEND: CONTROLLED BY
WIRING SYMBOLS DRAWING
EXCEPT AS NOTED AND BELOW.
LINE STYLES AND WIDTHS FOR
WIRE UNLESS NOTED OTHERWISE.

708B-W04 [B-W04]
WOOD'S POWR-GRIP CO., INC.
LAUREL,
MONTANA
U.S.A.

3 SCFM AC VACUUM PACKAGE
COMPACT ROTARY VANE
POWER SWITCH WIRING DIAGRAM
D708B-W04 [B-W04]

NOTE #1: ---
N/A
14AWG

DRAWN: L. RENNER
DATE: 12/08/2011

CHECKED: CR
DATE: 04-09-12

APPROVED: *Chen*
DATE: 4-9-12

REV: 1
ECN NUMBER: 2848
DATE: 03/22/2012
BY: RAS

- NOTES:
1) SEE PUMP WIRING DIAGRAM FOR SPECIFIC WIRE GAUGE.
2) POWER CONNECTORS SHOWN FROM WIRE CONNECTION END.

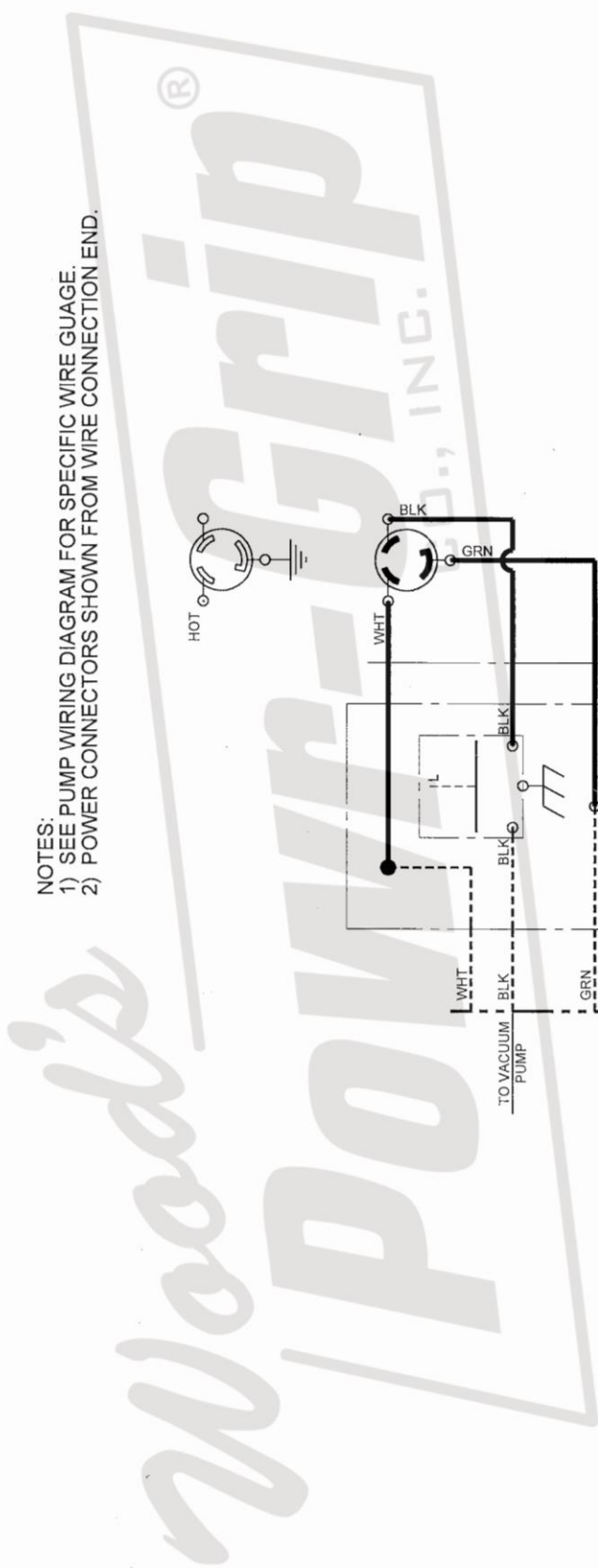
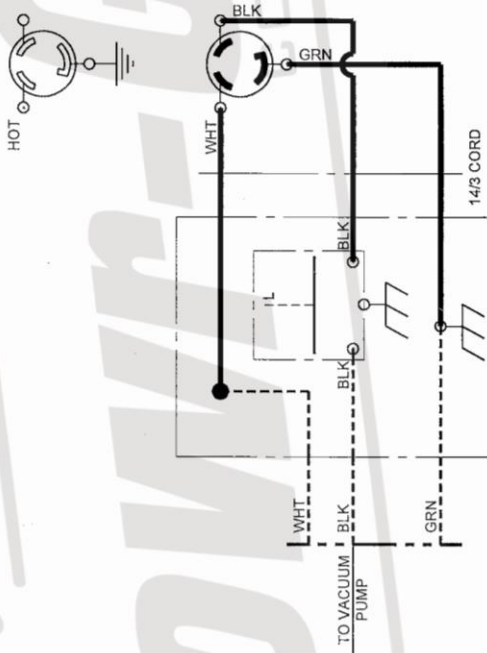

WIRE LEGEND: CONTROLLED BY WIRING SYMBOLS DRAWING EXCEPT AS NOTED AND BELOW. LINE STYLES AND WIDTHS FOR WIRE UNLESS NOTED OTHERWISE. NOTE #1 --- 20AWG - - - 18AWG - - - - 16AWG		TYPE: STANDARD		DIRECTORY: 708B-W04 [B-W05]	
DRAWN: L. RENNER		DATE: 12/08/2011		THIS DRAWING IS THE PROPERTY OF WOOD'S POWER-GRIP CO., INC. LAUREL, MONTANA U.S.A. IT IS LOANED WITH THE UNDERSTANDING THAT NEITHER IT NOR ANY INFORMATION CONTAINED THEREIN WILL BE COPIED, PUBLISHED OR TRANSMITTED TO OTHERS WITHOUT EXPRESS WRITTEN PERMISSION.	
CHECKED: CR		DATE: 04-09-12		3 SCFM AC VACUUM PACKAGE COMPACT ROTARY VANE POWER SWITCH WIRING DIAGRAM TO PUMP AND SOLENOID D708B-W04 [B-W05]	
APPROVED: Camr		DATE: 4-9-12		SIZE: A SCALE: NONE REV: 1 ECN NUMBER: 2848 BY: RAS	

NOTES:
 1) SEE PUMP WIRING DIAGRAM FOR SPECIFIC WIRE GAUGE.
 2) POWER CONNECTORS SHOWN FROM WIRE CONNECTION END.

