

MANUAL ROTATOR/ POWER TILTER 2000

MODEL: MRPT209CDC3

Packed with features, this adaptable 20-pad lifter from Powr-Grip® is the go-to choice for handling large curved-glass loads weighing up to 2,000 lbs (905 kg).

Pivoting Pad Mounts

Attach to curved glass loads with ease! Additionally, the offset of the pad mounts can be extended to handle more convex loads.

Intelli-Grip® Technology

Looking for better productivity and increased safety? Count on reliable monitoring of power and vacuum systems with Intelli-Grip® – available exclusively from WPG!

Dual Vacuum System

Handle loads with the added safeguard of two independent air-line circuits!

Load-Support Safety Sensor

Measures suspended weight; warns operator attempting to release a load that is not supported!

Intelli-Grip® App

Use your Android- or iOS-powered smartphone, tablet or other device on the job site to check vacuum levels, battery energy level and more on your WPG lifter!

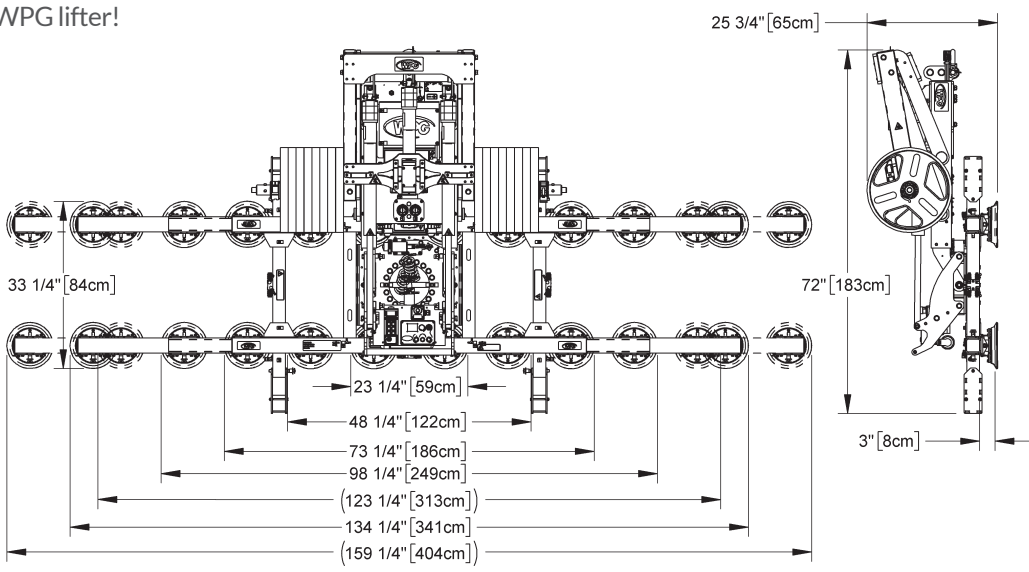

MRPT209CDC3 shown with optional Integrated Counter-Balancer

Model	MRPT209CDC3
Maximum Load Capacity	2,000 lbs [905 kg]
Load Movement	Manual rotation, 360° edgewise, with locking every 18° Power tilt, 90° between upright and flat
Standard Operating Power	12 volts DC, 50 amps
Time to Achieve 90° Tilt	45 seconds (approximately)
Standard Pad Spread	See drawings below
Number/Size of Vacuum Pads	20 / 9" [23 cm] diameter, concave
Lifter Weight	575 lbs [260 kg]
Lifter Weight with Integrated Counter-Balancer and all counterweight:	1,425 lbs [646 kg]

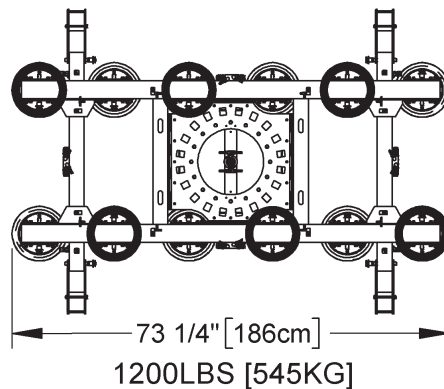
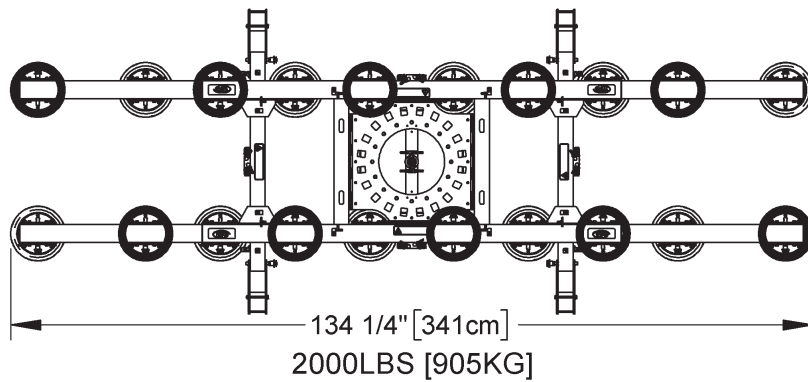
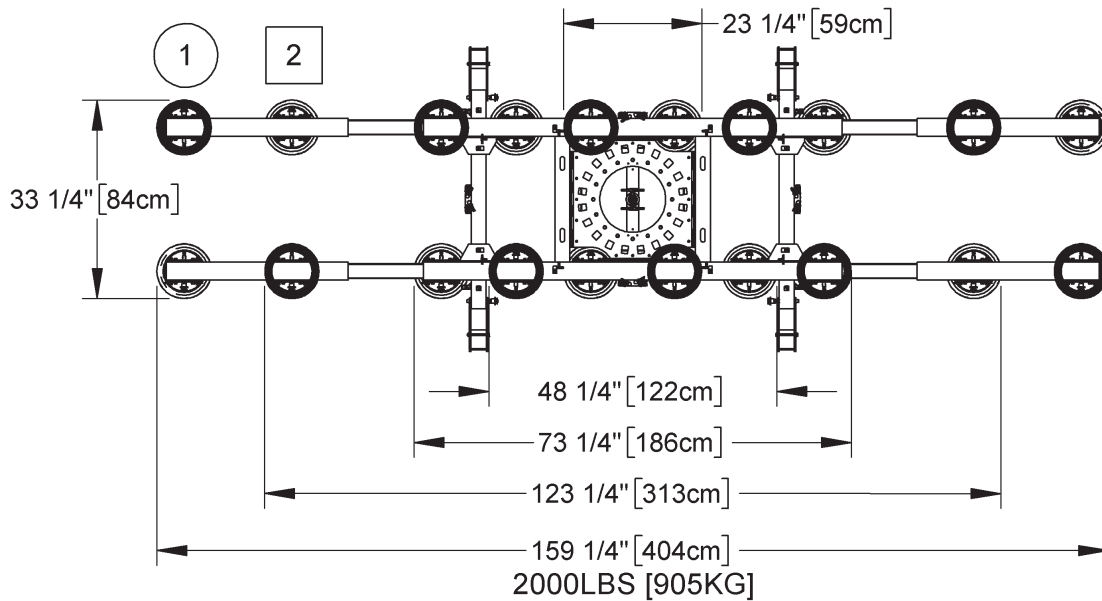
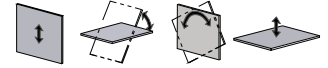

STANDARD FEATURES

Intelli-Grip® Technology

Available exclusively from Powr-Grip®! Actively monitors power and vacuum systems to increase safety and productivity, using LCD-screen messages, diagnostic codes and other features

Dual Vacuum System

Features two independent air-line circuits to reduce risk of workplace accidents

Remote Control System

Controls attach, release and other powered functions up to 250' [76 m] away for installing windows and more in multi-story buildings

Load-Support Safety Sensor

Measures weight suspended from hoisting equipment and warns operator attempting to release a load that is not supported

Notification Buzzer and Strobe Light

Alert operator of problems with power or vacuum system, with various patterns of sound and light to indicate severity; back-up battery provides independent power for buzzer

Green Lift Light

Provides visual assurance to know when vacuum is sufficient for lifting

Two-Action, Blow-Off Release

Uses two separate buttons to avoid accidental release, and reverses airflow to quickly release loads without after-stick

Battery and Charger

Provide independent, rechargeable power source for cord-free lifter operation in any location; on-board charger features status indicator and automatic shut-off

Battery Gauge

Shows energy level in real time, to help determine when charging is needed

Vacuum Gauges

Feature green and red zones to clearly indicate whether vacuum levels are sufficient for lifting

Vacuum Line Filters

Protect the vacuum generating system from contaminants

Vacuum Reserve Tanks

Increase battery run-time by reducing pump cycles needed to maintain vacuum

Pivoting Pad Mounts

Automatically adjust to match a variety of different curved loads

Telescoping Pad Arms

Can quickly be extended or retracted, to support many different load dimensions

(Re)movable Pad Mounts

Can be moved or removed without tools, adapting the lifter to various load sizes and weights

Spring-Mounted Vacuum Pads

Automatically adjust to match the angle of load surfaces, easing attachment

AVAILABLE OPTIONS

Integrated Counter-Balancer (98815)

Adjusts the hang angle of the lifter or load as needed for each job, such as aligning windows for efficient installation in rough openings; radio controls enable remote use



Independent Counter-Balancer

Features the same advantages as 98815, while adding the ability to reach under eaves, gables and other overhanging obstacles

Custom Pad Frame Sizes and Capacities

Accommodate customers' specific load weight and dimension requirements

Alternative Pad Compounds

Specially designed for heat resistance, marking resistance, coated surfaces and other purposes

DESIGN STANDARDS

ASME B30.20 (BTH-1 Design Category "B", Service Class "0"): Industry standards established by the American Society of Mechanical Engineers (ASME) and published by the American National Standards Institute (ANSI)

CE/UKCA: Regulatory standards for health and safety required in the European Union and the United Kingdom.

AS 4991: Regulatory standard required in Australia

Based on product information at time of publication.

Environmental conditions can affect product performance and longevity; consult the product instructions on WPG.com or contact a Technical Sales Representative for more information.

