



# VACUUM LOSS WARNING BUZZER

STOCK: 93781, 93781CM, 93781SM

The Vacuum Loss Warning Buzzer adds peace of mind to any Powr-Grip vacuum lifter. Its advanced circuitry ensures you hear an alarm only when vacuum loss poses a real hazard.



- **Universal Compatibility**

Works with all powered WPG lifters, as well as other brands.

- **Automatically Powers On/Off**

Turns on and off with lifter operation for effortless use.

- **Battery Condition Monitoring**

Audio alert notifies you when replacement is needed.

- **Independent DC Power Source**

AA batteries keep working, even during a power outage.

- **Battery Test Button**

Enables you to quickly check battery status when the lifter is not in use.

- **Durable Enclosure**

Built to withstand weather and demanding jobsite conditions.

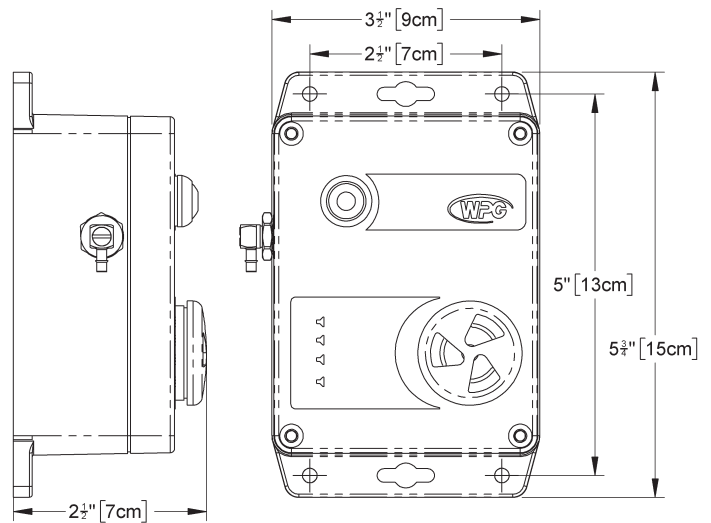

<b>Stock Numbers</b>	93781, 93781CM (center mounting plate), 93781SM (side mounting plate)
<b>Maximum Alarm Volume</b>	93 dBa at 2' (60 cm)
<b>Operating Temperatures</b>	32° - 104° F (0° - 40° C)
<b>Enclosure Dimensions</b>	5-3/4" (15 cm) height x 3-1/2" (9 cm) width x 2-1/2" (7 cm) depth
<b>Power Source</b>	6 volts DC (four AA type, nominal 1.5V batteries)
<b>Weight</b>	0.7 lbs (0.3 kg)
<b>*Specify lifter type when ordering.</b>	

## How It Works

While vacuum gauges or lights show vacuum levels on all Powr-Grip lifters, the **Vacuum Loss Warning Buzzer** increases safety by continuously monitoring vacuum during a lift and sounding an alarm, if vacuum should decrease to unsafe levels. The alarm stops sounding after adequate vacuum is restored.

This “smart” system automatically powers up when the lifter attaches to a load and powers down when the load is released. Unlike buzzers that sound before attaching or after releasing, this warning buzzer only sounds when inadequate vacuum could put your safety at risk. A power indicator light shows you when the warning buzzer is activated.

The warning buzzer also monitors battery condition during lifter operation and sounds an alert, if the batteries need to be replaced. Alternatively, you can press a button to instantly test battery condition at any time. Efficient circuitry makes batteries last longer.

