

# WOOD'S POWR-GRIP® GUIDE TO MAINTENANCE, TROUBLESHOOTING, AND REPAIR



3", 3" x 6", 4½" and 6"  
Vacuum Cups  
(Not all cups are pictured)



CLICK OR SCAN  
TO WATCH  
INSTRUCTIONAL VIDEO

## General Maintenance

### Inspect the Vacuum Cup Regularly:

- Make sure the air filter is in place; if not, discontinue use until the filter is replaced.
- Examine the plunger assembly and cylinder for cracks or other damage.
- Make sure the face of the vacuum pad feels grippy (not slick). Otherwise, replace the pad.
- Examine the vacuum pad for cuts or roughness on the sealing edge (see Inspect the Sealing Edge below).
- Periodically test the cup for excessive leakage (see Leak-Test the Vacuum Cup below), sluggishness in plunger action or radical changes in the number of strokes needed to keep the red line hidden.
- If the cup does not function normally, review the TROUBLESHOOTING GUIDE (overleaf) to determine which corrective action is needed.

### Clean the Vacuum Pad:

- Remove the air filter from the pad face.
- Use a clean sponge or lint-free cloth to apply soapy water or another mild cleanser to the pad face.  
**Never use solvents or rubber conditioners as a cleaning agent** (see WARNINGS).
- To prevent liquid from contaminating the pump during cleaning, hold the cup facedown or cover the suction inlet in the filter recess.
- Wipe all residue from the pad face and allow the cup to dry.
- Reinstall the air filter.



CLICK OR SCAN  
TO WATCH  
INSTRUCTIONAL VIDEO

## Inspecting and Testing the Cup for Leakage

### Inspect the Sealing Edge:

- Slowly draw your finger along the entire length of the sealing edges, to check for roughness or foreign material.
- Examine the sealing edge for cuts by bending the edge of the pad face towards you to create a hump, turning the vacuum cup as necessary.
- If cuts or cracks are present in a sealing edge, a V-shaped gap will appear.
- Any pad that exhibits a gap or excessive roughness in a sealing edge must be replaced.

### Leak-Test the Vacuum Cup:

- Attach the cup to a clean, smooth, scratch-free piece of glass or metal for approximately 2 hours.
- The red line on the plunger serves as a vacuum indicator:
  - If the red line *does not* appear during the test period, the cup is usable.
  - If the red line *does* appear, perform general maintenance and repeat the test.
- If the problem persists, check the TROUBLESHOOTING GUIDE (overleaf) to identify possible causes and appropriate corrective actions.
- If these measures do not restore the cup to normal performance, contact the Wood's Powr-Grip Customer Service department or an authorized dealer for assistance.

Based on product information at time of publication. Environmental conditions can affect product performance and longevity; consult the product instructions on [www.WPG.com](http://www.WPG.com) or contact a Technical Sales Representative for more information.



THE ORIGINAL  
& TRUSTED NAME  
IN VACUUM LIFTING  
EQUIPMENT

800.548.7341  
WPG.com

908 West Main - P.O. Box 368  
Laurel, Montana 59044 U.S.A.  
406.628.8231 (phone)  
406.628.8354 (fax)

Wood's Powr-Grip products are sold  
through authorized dealers.

Rev. 1.1/ 06-22 SC Troubleshooter **1STS**

# PARTS AND ASSEMBLY

Ref. Stock #	Description
1. <a href="#">90501</a>	Air Filter
2.	Release Tab
3.	Plunger
4.	Red Line
5.	Pump
6. <a href="#">49386T</a>	Vacuum Pad, 6" Dia., Concave Face
<a href="#">49426T</a>	Vacuum Pad, 6" Dia., Flat Face
7. <a href="#">10020</a>	Screw, 10-32 x 1/2"
8. <a href="#">50220</a>	Accessory Mount, Aluminum (for Tie-Down or Flip Handle)
<a href="#">50210</a>	Accessory Mount, Aluminum, 1/4-20 Stud
9. <a href="#">50230</a>	Rigid Handle
10. <a href="#">15790</a>	T-Handle (fits on 1/4-20 stud)
11. <a href="#">50100</a>	Tie-Down
12. <a href="#">50102</a>	Flip Handle
13. <a href="#">10156</a>	Screw, 10-32 x 1/4"
14. <a href="#">60118</a>	Accessory Mount, 1/4-20 Stud
15. <a href="#">60116</a>	Handi-Grip Handle (for 3" x 6" pads)
<a href="#">50205</a>	Handi-Grip Handle (for 4 1/2" x 6" pads)
16. <a href="#">49365T</a>	Vacuum Pad, 3 x 6", Concave Face
17. <a href="#">49323T</a>	Vacuum Pad, 3" Dia., Concave Face
18. <a href="#">10953</a>	Screw, 10-14 x 3/8"
19. <a href="#">60181</a>	Accessory Mount, Polycarbonate, 1/4-20 Insert
<a href="#">60180</a>	Accessory Mount, Polycarbonate, 1/4-20 Stud
20. <a href="#">49345T</a>	Vacuum Pad, 4 1/2" Dia., Concave Face
21.	Cylinder
22.	Check Valve (Rubber)
23.	Retainer
24.	Button
25.	U-Cup
26.	Plunger Assembly
27.	Valve Stem
	Not Shown
<a href="#">29306MM</a>	Pad Cover, 3"
<a href="#">29308</a>	Pad Cover, 4 1/2"
<a href="#">29312</a>	Pad Cover, 6"
<a href="#">29322AM</a>	2-Cup Case, 4 1/2" or 6" (for Rigid Handle, Tie-Down or Flip Handle cups)
<a href="#">29322BM</a>	2-Cup Case, 4 1/2" or 6" (for Handi-Grip cups)
<a href="#">28502</a>	Plunger Lube

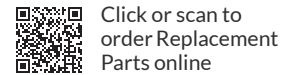
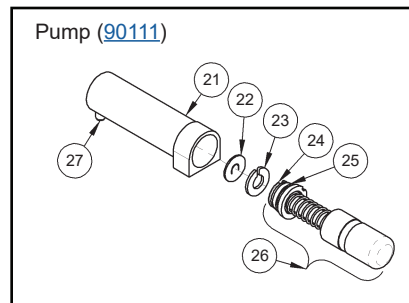
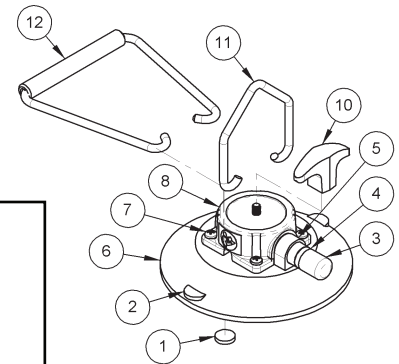
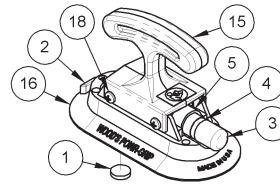
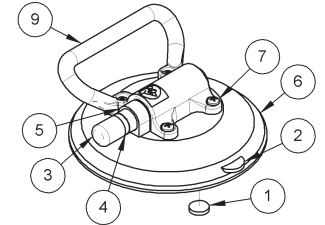
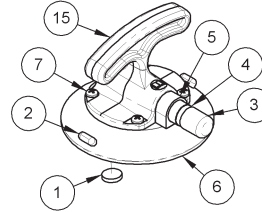
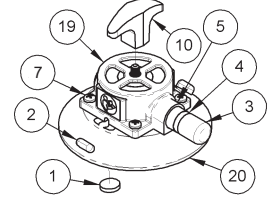
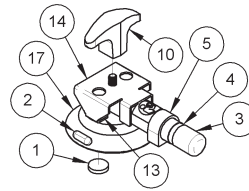

## TROUBLESHOOTING GUIDE

PROBLEM	CAUSE	CORRECTION
<b>Slow leakage</b>	Cuts on sealing edge	Replace vacuum pad.
	Dirt or lint inside pump	Wipe inside of cylinder with a soft cloth. Check for contamination on U-cup or button.
	Dry pump	Apply a light coating of plunger lube inside cylinder.
	Scratches inside cylinder (between mid-point and closed end)	Replace pump.
	Contaminated pad face	Clean vacuum pad.
<b>Severe leakage</b>	Gouges or cuts on sealing edge	Replace vacuum pad.
	Damaged pump	Replace pump.
<b>Jammed or sluggish pump</b>	Dry pump	Apply a light coating of plunger lube to U-cup.
	Obstructed valve stem	Remove obstruction (through suction inlet behind air filter).
	Severe contamination	Clean plunger assembly and inside of cylinder.
<b>Pad slips when attached</b>	Contaminated contact surface	Wipe surface clean. If necessary, wash and allow to dry.
	Contaminated pad face	Clean vacuum pad.
	Slick or worn pad face	Replace vacuum pad (at least once every two years).
<b>More than 10 strokes needed to apply</b>	Any of the above	Perform general maintenance.
	Dirt or lubricant on check valve	Remove, clean and reinstall plunger assembly, retainer and check valve as directed in Disassembly and Assembly sections (on facing page).

## Disassembly Procedures



### Remove Plunger Assembly from Cylinder

- Grasp the head of the plunger assembly and pull it straight out from the cylinder.
- Wipe the plunger assembly clean with a soft, lint-free cloth. **Be careful to keep the plunger assembly clean when it is not in the handle.**



### Remove Handle/Mount and Cylinder from Vacuum Pad

- Remove the screws that attach the handle/mount to the pad.
- Separate the handle/mount from the pad.
- Carefully remove the valve stem from the rubber nipple on the pad by gently pulling on the cylinder and twisting it back and forth.

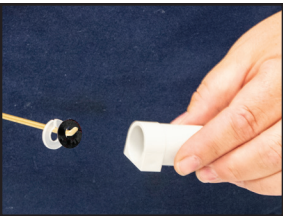

### Remove Retainer and Check Valve from Cylinder

- Remove the retainer and check valve using a hooked scribe or similar tool. **Be careful not to scratch the inside of the cylinder!**
- With a soft, lint-free cloth, carefully clean these parts.
- Wrap a small dowel or rod with a soft, lint-free cloth and gently wipe the inside of the cylinder, to make sure it is clean and dry (lubricant-free).

## Assembly Procedures



### Inspect Cylinder and Reinstall Check Valve and Retainer

- Carefully examine the inside of the cylinder for scratches and contaminants, using a flashlight.
  - Scratches between the mid-point and the closed end of the cylinder can cause leakage.
  - Scratches near the open end of the cylinder rarely present a problem.
  - Make sure that no lubricant remains inside the cylinder.
- Drop the check valve inside the cylinder so that it lies flat against the closed end.
- Using a dowel or other tool that will not scratch the sides of the cylinder, push the retainer all the way into the cylinder to hold the check valve securely in place.

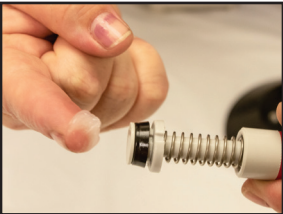

### Reinsert Plunger Assembly into Cylinder and Pump into Vacuum Pad

- Apply plunger lube all the way around the exposed surface of the U-cup. **Be careful to keep lubricant off the button!**
- Plunger lube is recommended; contact Wood's Powr-Grip Customer Service to order this. **Do not use improper lubricants in the pump!**
- While making certain the button, check valve and retainer remain free of lubricant, insert the U-cup end of the plunger assembly into the cylinder, and gently push until the plunger assembly bottoms out.
- Operate the plunger, turning it to spread the plunger lube thoroughly.
- Apply a light coating of plunger lube to the valve stem of the assembled pump, and insert the valve stem into the pad nipple.

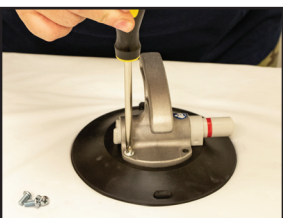
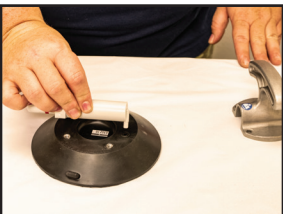

### Attach Handle/Mount to Vacuum Pad

- Carefully place the handle/mount over the pump and onto the pad, and align the screw holes. The pump should fit snugly under the handle/mount but should not bind.
- Reinstall the handle/mount screws and tighten them securely.
- Now the cup is assembled and ready for testing.

# WARNINGS

Wood's Powr-Grip has taken great care to produce the most reliable vacuum-operated handling and mounting devices available. Nevertheless, mistreatment or misuse may damage a vacuum cup or otherwise create conditions which could cause the vacuum cup to fail, resulting in an unexpected release. The following warnings are offered to help users avoid most potential hazards.

**Failure to observe WARNINGS could damage the cup or the load, or cause injury to the user.**

- Do not use the cup with loads that exceed the load capacity.
- Do not use the cup to support a person.
- Do not leave a cup unattended that could injure people if it disengages unexpectedly.
- Do not place the vacuum pad against surfaces that could damage the sealing edges.
- Avoid conditions that could cause the cup to slip or to disengage prematurely, such as: contaminants, cuts or scratches in the pad face or contact surface; attaching the cup to porous materials; or applying pressure against the pad edge.
- Do not use the cup when the red line is visible. If the red line reappears frequently, discontinue use and follow the instructions for general maintenance and testing.
- Do not allow anything to interfere with free movement of the plunger while the cup is attached. This could prevent the red line from warning the user of vacuum loss.
- Do not touch any release tab while using the cup.
- Do not use harsh chemicals (such as solvents or gasoline) or rubber cleaners and conditioners to clean the cup. See [www.WPG.com](http://www.WPG.com) for more information.