

MRTALPR4FS625DC

600 lbs [270 kg]

up to 1100 lbs [500 kg]
with available options

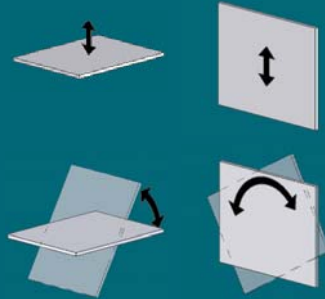

PANEL MASTER VACUUM LIFTER
LOW-PROFILE MANUAL ROTATOR/TILTER 600
WITH PAD FRAME T-ARM ASSEMBLIES



Standard Pad Spread	Maximum - 37" x 92-1/2" [940 mm x 2352 mm] Minimum - 20" x 92-1/2" [508 mm x 2352 mm]
Number / Style of Pads	4 / 6-1/2" x 25-1/2" [17 cm x 65 cm] foam rubber vacuum pads
Maximum Load Capacity (On smooth, nonporous surfaces. Please contact us for recommendations on other surfaces.)	600 lbs [270 kg] for load thickness up to 12" [30 cm] 1100 lbs [500 kg] for flat lift with 8-pad options (see page 2)
Unit Weight	229 lbs [104 kg]
Standard Operating Power	12 volts DC, 5 amps
Load Movement	Manual rotation, 180° edgewise, with automatic latching every 30° Assisted manual tilt, 90° between upright and flat, with automatic latching in upright position
Profile Thickness	9 3/4" [250 mm] (does not include load)
Standard Features	Adjustable-position lift spool Dual vacuum system Low vacuum strobe light Low vacuum warning buzzer Green lift light On-board high-capacity battery and charger Battery energy gauge Vacuum gauges Vacuum line filters Vacuum reserve tanks Blow-off for quick release Pad frame T-arm assemblies Sliding vacuum pad mounts Spring-mounted vacuum pads
Available Options	Pad frame extension arms for roof panels (CF14CEO; see page 2) Pad frame rocker arms for roof panels (CF15CEO; see page 2) Pad frame T-arm assemblies (CF13CEO; see page 2) (specify VPFS625 or HV11F vacuum pads) Remote control system (EO8RC1) Alternative HV11F pad option (see Spec Sheet 8-11a) Vacuum pad extension arms (MRTALP611LDC or MRTALP6HV11FDC)
Design Standards (See www.powrgrip.com for more information.)	ASME B30.20-2006 (BTH-1 Design Category "B", Service Class "0") CE

**THE ORIGINAL
& TRUSTED NAME
IN VACUUM LIFTING
EQUIPMENT**

Wood's Powr-Grip Co., Inc.
908 West Main - P.O. Box 368
Laurel, Montana 59044 U.S.A.
406.628.8231 (phone)
406.628.8354 (fax)

800.548.7341
www.powrgrip.com



Products are manufactured under an ISO 9001 quality management system

Wood's Powr-Grip products are sold through authorized dealers.

FOR DETAILED SPECIFICATIONS SEE INSTRUCTIONS

Environmental conditions can affect product performance and longevity; consult the product instructions on www.powrgrip.com or contact a Technical Sales Representative for more information.
Based on product information at time of publication.

PAD FRAME CONFIGURATIONS & CAPACITIES WITH VPFS625 PADS

Accommodates panels over 35 ft [10.5 m] in the standard configuration
(maximum size shown - narrower configurations possible)

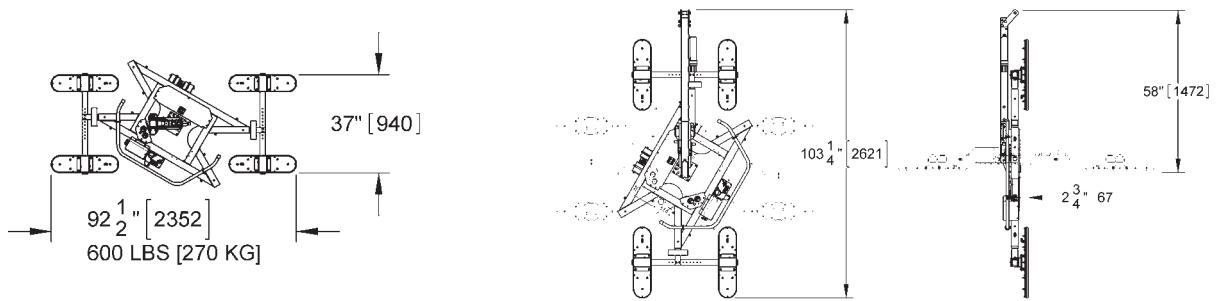

Accommodates panels over 55 ft [17 m] with the following options: CF14CEO*
(maximum size show - smaller configurations possible)

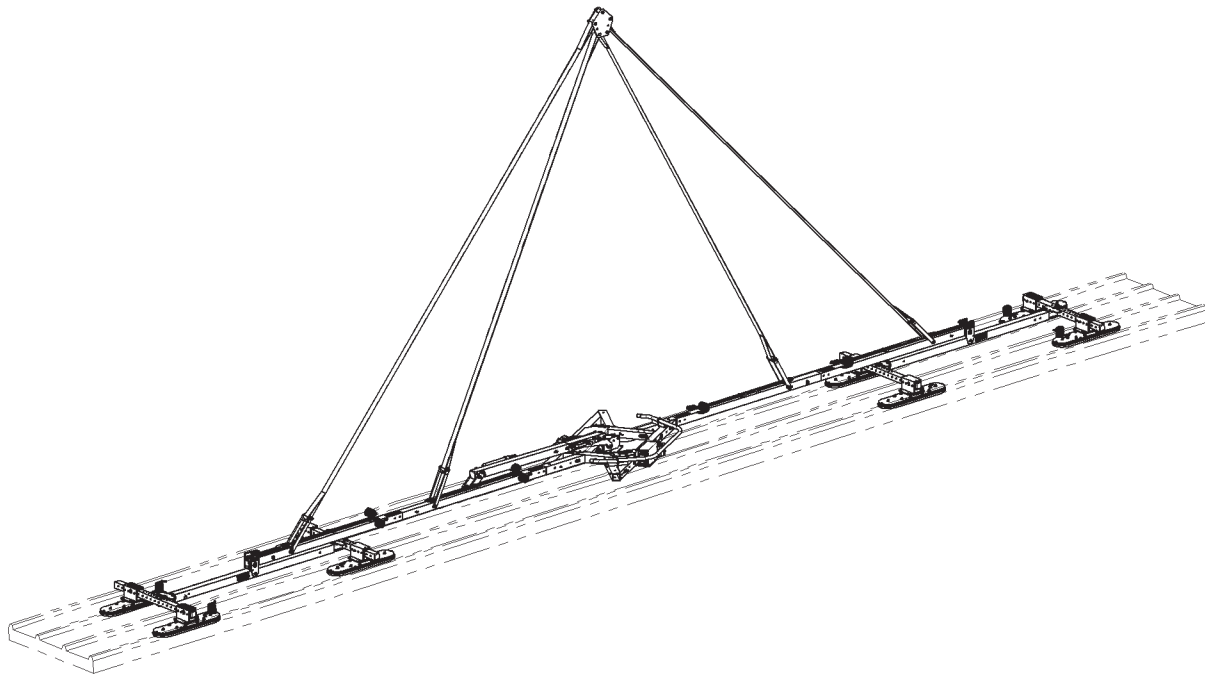
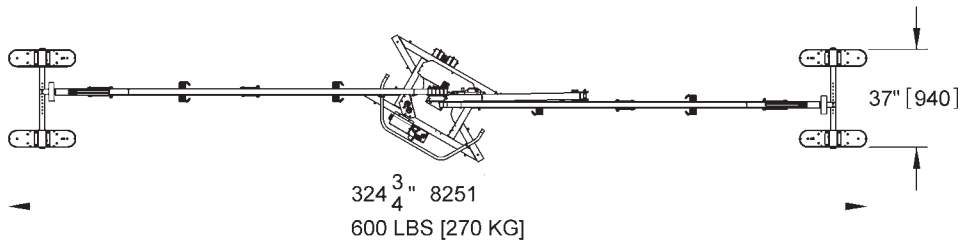

Accommodates panels over 60 ft [18.5 m] with the following options: CF15CEO*, CF14CEO*, CF13CEO*
(maximum size shown - smaller configurations possible)

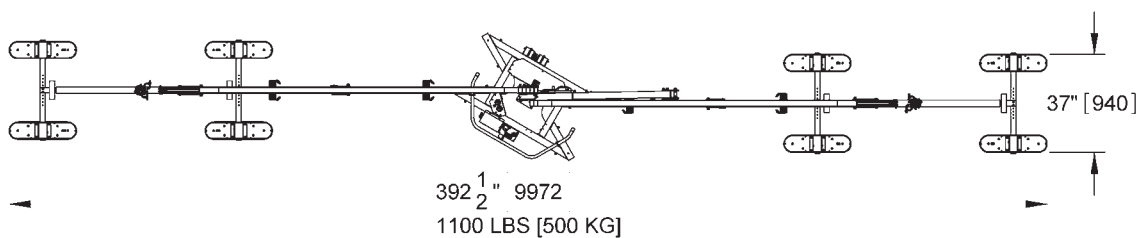

* FOR LIFTING LOADS IN FLAT ORIENTATION ONLY.